

# **ELECTRON TUBES**

**Part 4**

**June 1972**

---

General section

Receiving tubes

---

# DATA HANDBOOK SYSTEM

To provide you with a comprehensive source of information on electronic components, subassemblies and materials, our Data Handbook System is made up of three series of handbooks, each comprising several parts.

The three series, identified by the colours noted, are:

**ELECTRON TUBES** (9 parts) BLUE

**SEMICONDUCTORS AND INTEGRATED CIRCUITS** (6 parts) RED

**COMPONENTS AND MATERIALS** (7 parts) GREEN

The several parts contain all pertinent data available at the time of publication, and each is revised and reissued annually; the contents of each series are summarized on the following pages.

We have made every effort to ensure that each series is as accurate, comprehensive and up-to-date as possible, and we hope you will find it to be a valuable source of reference. Where ratings or specifications quoted differ from those published in the preceding edition they will be pointed out by arrows. You will understand that we can not guarantee that all products listed in any one edition of the handbook will remain available, or that their specifications will not be changed, before the next edition is published. If you need confirmation that the published data about any of our products are the latest available, may we ask that you contact our representative. He is at your service and will be glad to answer your inquiries.

December 1971

## **ELECTRON TUBES (BLUE SERIES)**

This series consists of the following parts, issued on the dates indicated.

- |               |  |                                   |
|---------------|--|-----------------------------------|
| <b>Part 1</b> | <b>Transmitting tubes (Tetrodes, Pentodes);<br/>Amplifier circuit assemblies</b> | <b>January 1972</b>               |
| <b>Part 2</b> | <b>Tubes for microwave equipment</b>   | <b>February 1972</b>              |
| <b>Part 3</b> | <b>Special Quality tubes;<br/>Miscellaneous devices</b>                          | <b>March 1972</b>                 |
| <b>Part 4</b> | <b>Receiving tubes</b>   | <b>June 1972</b>                  |
| <b>Part 5</b> | <b>Cathode-ray tubes; Photo tubes; Camera tubes</b>                              | <b>May 1971</b>                   |
| <b>Part 6</b> | <b>Devices for nuclear equipment</b>   | <b>June 1971</b>                  |
|               | Photomultiplier tubes  | Radiation counter tubes           |
|               | Channel electron multipliers   | Semiconductor radiation detectors |
|               | Scintillators  | Neutron generator tubes           |
|               | Photoscintillators   | Photo diodes                      |
| <b>Part 7</b> | <b>Gas-filled tubes</b>  | <b>July 1971</b>                  |
|               | Voltage stabilizing and reference tubes  | Thyratrons                        |
|               | Counter, selector, and indicator tubes   | Ignitrons                         |
|               | Trigger tubes  | Industrial rectifying tubes       |
|               | Switching diodes   | High-voltage rectifying tubes     |
| <b>Part 8</b> | <b>T.V. Picture tubes</b>  | <b>August 1971</b>                |
| <b>Part 9</b> | <b>Transmitting tubes (Triodes) ;<br/>Tubes for r.f. heating (Triodes)</b>       | <b>December 1971</b>              |

# SEMICONDUCTORS AND INTEGRATED CIRCUITS (RED SERIES)

This series consists of the following parts, issued on the dates indicated.

|  |                                    |                       |
|--|------------------------------------|-----------------------|
| <b>Part 1</b>  | <b>Diodes and Thyristors</b>       | <b>September 1971</b> |
| General  | Thyristors, diacs, triacs          |                       |
| Signal diodes  | Rectifier stacks                   |                       |
| Variable capacitance diodes                                  | Accessories                        |                       |
| Voltage regulator diodes                                     | Heatsinks                          |                       |
| Rectifier diodes   |                                    |                       |
| <b>Part 2</b>  | <b>Low frequency; Deflection</b>   | <b>October 1971</b>   |
| General  | Deflection transistors             |                       |
| Low frequency transistors (low power)                        | Accessories                        |                       |
| Low frequency power transistors                              |                                    |                       |
| <b>Part 3</b>  | <b>High frequency; Switching</b>   | <b>November 1971</b>  |
| General  | Switching transistors              |                       |
| High frequency transistors                                   | Accessories                        |                       |
| <b>Part 4</b>  | <b>Special types</b>               | <b>December 1971</b>  |
| General  | Photoconductive devices            |                       |
| Transmitting transistors                                     | Photodiodes                        |                       |
| Microwave devices  | Phototransistors                   |                       |
| Field effect transistors                                     | Light emitting diodes              |                       |
| Dual transistors   | Infra-red sensitive devices        |                       |
| Microminiature devices for<br>thick- and thin -film circuits | Accessories                        |                       |
| <b>Part 5</b>  | <b>Linear Integrated Circuits</b>  | <b>February 1972</b>  |
| General  | Linear integrated circuits         |                       |
| <b>Part 6</b>  | <b>Digital integrated circuits</b> | <b>March 1972</b>     |
| General  | TTL (GJ family)                    |                       |
| DTL (FC family)  | CML (GH family)                    |                       |
| DTL/HNIL (FZ family)   | MOS (FD family)                    |                       |
| TTL (FJ family)  |                                    |                       |



# COMPONENTS AND MATERIALS (GREEN SERIES)

This series consists of the following parts, issued on the dates indicated.

## **Part 1 Circuit Blocks, Input/Output Devices, October 1971** **Electro-mechanical Components \*), Peripheral Devices**

|                              |                                  |
|------------------------------|----------------------------------|
| Circuit blocks 40-Series     | Input/output devices             |
| Counter modules 50-Series    | Electro-mechanical components *) |
| Norbits 60-Series, 61-Series | Peripheral devices               |
| Circuit blocks 90-Series     |                                  |

## **Part 2 Resistors, Capacitors December 1971**

|                      |                                      |
|----------------------|--------------------------------------|
| Fixed resistors      | Paper capacitors and film capacitors |
| Variable resistors   | Electrolytic capacitors              |
| Non-linear resistors | Variable capacitors                  |
| Ceramic capacitors   |                                      |

## **Part 3 Radio, Audio, Television February 1972**

|   |  |
|---|--|
| FM tuners                                       | Audio and mains transformers               |
| Coil assemblies                                 | Television tuners, aerial input assemblies |
| Piezoelectric ceramic resonators<br>and filters | Components for black and white television  |
| Loudspeakers                                    | Components for colour television           |
|   | Deflection assemblies for camera tubes     |

## **Part 4 Magnetic Materials, Piezoelectric Ceramics, Ni Cd cells May 1972**

|   |                                  |
|---|----------------------------------|
| Ferrites for radio, audio<br>and television | Ferroxcube transformer cores     |
| Small coils and assembling parts            | Piezoelectric ceramics           |
| Ferroxcube potcores and square cores        | Permanent magnet materials       |
|   | Cylindrical nickel cadmium cells |

## **Part 5 Memory Products, Magnetic Heads, Quartz Crystals, June 1971** **Microwave Devices, Variable Transformers**

|                              |                                       |
|------------------------------|---------------------------------------|
| Ferrite memory cores         | Quartz crystal units, crystal filters |
| Matrix planes, matrix stacks | Isolators, circulators                |
| Complete memories            | Variable mains transformers           |
| Magnetic heads               |                                       |

## **Part 6 Electric Motors and Accessories, August 1971** **Timing and Control Devices**

|                          |  |
|--------------------------|--|
| Stepper motors           | Small d. c. motors                     |
| Small synchronous motors | Tachogenerators and servomotors        |
| Asynchronous motors      | Indicators for built-in test equipment |

## **Part 7 Circuit Blocks September 1971**

|                              |                                 |
|------------------------------|---------------------------------|
| Circuit blocks 100kHz Series | Circuit blocks for ferrite core |
| Circuit blocks 1-Series      | memory drive                    |
| Circuit blocks 10-Series     |                                 |

\*) From October 1971 published in Part 1 instead of Part 5.

May 1972

**Argentina**

FAPESA I.y.C.  
Melincué 2594  
Tel. 50-9941/8155  
BUENOS AIRES

**Australia**

Philips Industries Ltd.  
Elcoma Division  
95-99 York Street  
Tel. 20223  
SYDNEY, N.S.W. 2000

**Austria**

WIVEG  
Zieglergasse 6  
Tel. 93 26 22  
A1072 VIENNA

**Belgium**

M.B.L.E.  
80, rue des Deux Gares  
Tel. 23 00 00  
1070 BRUSSELS

**Brazil**

IBRAPE S.A.  
Av. Paulista 2073-S/Loja  
Tel. 278-1111  
SAO PAULO, SP

**Canada**

Philips Electron Devices  
116, Vanderhoof Ave.  
Tel. 425-5161  
TORONTO 17, Ontario

**Chile**

Philips Chilena S.A.  
Av. Santa Maria 0760  
Tel. 39-40 01  
SANTIAGO

**Colombia**

SADAPE S.A.  
Calle 19, No. 5-51  
Tel. 422-175  
BOGOTA D.E. 1

**Denmark**

Miniwatt A/S  
Emdrupvej 115A  
Tel. (01) 69 16 22  
DK-2400 KØBENHAVN NV

**Finland**

Oy Philips Ab  
Elcoma Division  
Kaivokatu 8  
Tel. 65 80 33  
SF-00100 HELSINKI 10

**France**

R.T.C.  
La Radiotechnique-Compelec  
Avenue Ledru Rollin 130  
Tel. 357-69-30  
PARIS 11

**Germany**

Valvo G.m.b.H.  
Valvo Haus  
Burchardstrasse 19,  
Tel. (0411) 3296-1  
2 HAMBURG 1

**Greece**

Philips S.A. Hellénique  
Elcoma Division  
52, Av. Syngrou  
Tel. 915 311  
ATHENS

**Hong Kong**

Philips Hong Kong Ltd.  
Components Dept.  
St. George's Building, 21st Fl.  
Tel. K-42 82 05  
HONG KONG

**India**

IMBELEC Div. of  
Philips India Ltd.  
Band Box House  
254-D, Dr. Annie Besant Road  
Tel. 475 311 to 15  
Worli, BOMBAY 18 (WB)

**Indonesia**

P.T. Philips-Rain Electronics  
Elcoma Division  
Djalan Gadjah Mada 18  
Tel. 44 163  
DJAKARTA

**Ireland**

Philips Electrical (Ireland) Ltd.  
Newstead, Clonskeagh  
Tel. 69 33 55  
DUBLIN 14

**Italy**

Philips S.p.A.  
Sezione Elcoma  
Piazza IV Novembre 3  
Tel. 69 94  
MILANO

**Japan**

NIHON PHILIPS  
32nd Fl. World Trade Center Bldg.  
5, 3-chome, Shiba Hamamatsu-su-cho  
Minato-ku  
Tel. (435) 5204-5  
TOKYO

**Mexico**

Electrónica S.A. de C.V.  
Varsovia No. 36  
Tel. 5-33-11-80  
MEXICO 6, D.F.

**Netherlands**

Philips Nederland N.V.  
Afd. Elonco  
Boschdijk, VB  
Tel. (040) 43 33 33  
EINDHOVEN

**New Zealand**

EDAC Ltd.  
70-72 Kingsford Smith Street  
Tel. 873 159  
WELLINGTON

**Norway**

Electronica A/S  
Middelthunsgate 27  
Tel. 46 39 70  
OSLO 3

**Peru**

CADESA  
Jr. Ilo, No. 216  
Appartado 10132  
Tel. 27 7317  
LIMA

**Portugal**

Philips Portuguesa S.A.R.L.  
Rua Joaquim Antonio de Aguiar 66  
Tel. 68 31 21/9  
LISBOA

**South Africa**

EDAC (Pty.) Ltd.  
South Park Lane  
New Doornfontein  
Tel. 232 66 80  
JOHANNESBURG

**Spain**

COPRESA S.A.  
Balmas 22  
Tel. 232 66 80  
BARCELONA 7

**Sweden**

ELCOMA A.B.  
Lidingövägen 50  
Tel. 08/67 97 80  
10250 STOCKHOLM 27

**Switzerland**

Philips A.G.  
Edenstrasse 20  
Tel. 051/44 22 11  
CH-8027 ZUERICH

**Taiwan**

Philips Taiwan Ltd.  
San Min Building, 3rd Fl.  
57-1, Chung Shan N. Road  
Section 2  
Tel. 553101-5  
TAIPEI

**Turkey**

Turk Philips Ticaret A.S.  
EMET Department  
Gümüssuyu Cad. 78-80  
Tel. 45.32.50  
Beyoğlu, ISTANBUL

**United Kingdom**

Mullard Ltd.  
Mullard House  
Torrington Place  
Tel. 01-580 6633  
LONDON WC1E 7HD

**United States**

North American Philips  
Electronic Component Corp.  
230, Duffy Avenue  
Tel. (516) 931-6200  
HICKSVILLE, N.Y. 11802

**Uruguay**

Luzilectron S.A.  
Rondeau 1567, piso 5  
Tel. 9 43 21  
MONTEVIDEO

**Venezuela**

C.A. Philips Venezolana  
Elcoma Department  
Colinas de Bello Monte  
Tel. 72.01.51  
CARACAS

---

---

## LIST OF SYMBOLS

### Symbols denoting electrodes and electrode/element connections

|   |                |
|---|----------------|
| Heater or filament                              | f              |
| Heater or filament tap                          | f <sub>C</sub> |
| Cathode   | k              |
| Input cathode lead                              | k <sub>i</sub> |
| Output cathode lead                             | k <sub>O</sub> |
| Grid  | g              |
| Electrostatic deflection plate or rod           | D              |
| Fluorescent screen                              | ℓ              |
| Anode   | a              |
| Anode of a detection diode                      | d              |
| Tube pin which must not be connected externally | i. c.          |
| Tube pin which may be connected externally      | n. c.          |
| External conductive coating                     | m              |
| Internal shield                                 | s              |

### Remarks

Equivalent electrodes of a multiple unit tube are distinguished by means of accents; e.g. the anodes of a double-anode rectifying tube are indicated by a and a'.

Similar electrodes of the same electrode system are distinguished by means of an additional numeral; the electrode nearest to the cathode has the lowest number.

The electrodes of multiple-unit tubes, in which the units are different, are distinguished by means of the following indices:

|                   |   |
|-------------------|---|
| diode             | D |
| triode            | T |
| tetrode           | Q |
| pentode           | P |
| hexode or heptode | H |

---

---

Symbols denoting voltages (average values unless otherwise stated)

|  |              |
|--|--------------|
| Symbol for voltage, followed by an index denoting the relevant electrode/element | V            |
| Heater or filament voltage   | $V_f$        |
| Peak value of a voltage  | $V_p$        |
| Peak to peak value of a voltage  | $V_{pp}$     |
| Supply voltage of tube electrodes  | $V_b$        |
| Anode voltage of a detection diode   | $V_d$        |
| RMS value of a voltage   | $V_{RMS}$    |
| Heater starting voltage  | $V_{fo}$     |
| Grid voltage   | $V_g$        |
| A.C. input voltage   | $V_i$        |
| Voltage between cathode and heater   | $V_{kf}$     |
| D.C. voltage supplied by a rectifying tube                                       | $V_o$        |
| A.C. output voltage  | $V_o$        |
| Voltage for gain control   | $V_R$        |
| Transformer voltage (secondary)  | $V_{tr}$     |
| Anode voltage under cold condition or cut-off condition ( $I_k$ approx. 0)       | $V_{a_0}$    |
| Screen grid voltage under cold condition or cut-off condition ( $I_k$ approx. 0) | $V_{g_{20}}$ |

Remarks

In the case of indirectly heated tubes the electrode voltages are specified with respect to the cathode.

In the case of directly heated tubes the electrode voltages are specified with respect to the negative terminal of the filament, unless otherwise stated.

---

---

Symbols denoting currents

Remarks

The positive electrical current is directed opposite to the direction of the electron current.

The symbols quoted represent average values unless otherwise stated.

Symbol for current followed by an index  
denoting the relevant electrode

I

Heater or filament current

$I_f$

Anode current

$I_a$

Current of a detection diode

$I_d$

RMS value of a current

$I_{RMS}$

Grid current

$I_g$

Cathode current

$I_k$

Current to fluorescent screen

$I_l$

D.C. current supplied by a rectifying tube

$I_o$

Peak value of a current

$I_p$

Symbols denoting powers

Symbol for power followed by an index  
denoting the relevant electrode

W

Anode dissipation

$W_a$

Grid dissipation

$W_g$

Input power

$W_i$

Anode supply D.C. power

$W_{i_a}$

Dissipation of a fluorescent screen

$W_l$

Output power

$W_o$

Symbols denoting capacitances

See IEC Publication 100

---

---

Symbols denoting resistance and impedance

When for one of the following symbols Z is used instead of an R the word "resistance" should read "impedance"

|   |              |
|---|--------------|
| External resistance in an anode lead                            | $R_a$        |
| External A.C. resistance or load resistance<br>in an anode lead | $R_{a\sim}$  |
| Load resistance of a push-pull amplifier<br>(anode to anode)    | $R_{aa\sim}$ |
| Equivalent noise resistance                                     | $R_{eq}$     |
| External resistor in a grid lead or<br>grid circuit resistance  | $R_g$        |
| Input resistance  | $r_g$        |
| Internal resistance   | $R_i$        |
| Resistor in a cathode lead                                      | $R_k$        |
| External resistance between cathode and heater                  | $R_{kf}$     |
| Protecting resistance in the anode lead of<br>a rectifying tube | $R_t$        |

---

---

Symbols denoting various quantities

|   |               |
|---|---------------|
| Brightness  | B             |
| Bandwidth   | B             |
| Distortion factor   | d             |
| n-th harmonic distortion                                      | $d_n$         |
| Noise factor  | F             |
| Frequency   | f             |
| Pulse repetition rate   | $f_{imp}$     |
| Power gain  | G             |
| Voltage gain  | $V_o/V_{i,g}$ |
| Height above sea level  | h             |
| Magnetic field strength                                       | H             |
| Cross modulation factor                                       | K             |
| Hum modulation factor   | $m_b$         |
| Transformer ratio   | n             |
| Transconductance  | S             |
| Conversion conductance  | $S_c$         |
| Effective transconductance of an oscillator                   | $S_{eff}$     |
| Temperature   | t             |
| Ambient temperature   | $t_{amb}$     |
| Time  | T             |
| Averaging time of current or voltages                         | $T_{av}$      |
| Cathode heating time  | $T_h$         |
| Pulse duration  | $T_{imp}$     |
| Shadow section on a fluorescent screen                        | $\alpha$      |
| Light sector on a fluorescent screen                          | $\beta$       |
| Duty factor   | $\delta$      |
| Phase angle   | $\varphi$     |
| Efficiency  | $\eta$        |
| Wave length   | $\lambda$     |
| Amplification factor  | $\mu$         |
| Amplification factor of grid No. 2 with respect to grid No. 1 | $\mu_{g2g1}$  |





---

---

# GENERAL OPERATIONAL RECOMMENDATIONS RECEIVING TUBES

## CONTENTS

1. General
2. Spread in tube characteristics
3. Spread and variation in operating conditions
4. Limiting values
5. Electrode voltages
6. Electrode current
7. Electrode dissipation
8. Heater circuit
9. Heater-to-cathode circuit
10. Suppressor grid circuit
11. Control grid circuit
12. Capacitances
13. Protective resistors for mains rectifying tubes
14. Life
15. Hum
16. Microphony
17. Environmental conditions
18. Mounting and wiring.

---

---

# GENERAL OPERATIONAL RECOMMENDATIONS RECEIVING TUBES

## 1. GENERAL

Where deviations from these directives are permissible or necessary, statements to that effect will be made on the relevant data sheets. If applications are considered not referred to in the data sheet of the relevant tube type extra care should be taken with circuit design to avoid that the tube is overloaded due to unfavourable operating conditions.

Users are warned for applying a tube in circuits where use is made of tube characteristics not controlled by the manufacturer. When at a later date batches of tubes are delivered which show different values for these characteristics this may result in unsatisfactory performance of the equipment.

## 2. SPREAD IN TUBE CHARACTERISTICS

Equipment design should be based on the characteristics as stated in the data sheets.

Tube data not stated as maximum or minimum values apply to a nominal tube. When measurements are carried out on a small number of tubes, and in particular on new tube types it should be taken into account that average values and the spread figures may differ from those obtained for larger quantities.

No guarantee is given for values of characteristics in settings substantially differing from those specified in the data sheets.

## 3. SPREAD AND VARIATION IN OPERATING CONDITIONS

The operating conditions of the tube in the equipment are expressed as a number of parameter values each of which is subject to spread and/or variation.

3.1 Spread. Spread in a parameter value will result in individual values deviating permanently from the average value; spread is due to e.g. component value deviations. The average value is the average of such a number of individual values taken at random that an increase of the number will have a negligible influence on the average value.

3.2 Variation. Variation of a parameter value is the change of value occurring as a function of time, e.g. due to supply voltage fluctuations.

The average value is calculated over a period such that a prolongation of that period will have a negligible influence on the average value.

---

---

#### 4. LIMITING VALUES

4.1 Limiting values are in accordance with the applicable rating system as defined by I.E.C. publication 134.

Reference may be made to one of the following 3 rating systems.

4.1.1 Absolute maximum rating system. Absolute maximum ratings are limiting values of operating and environmental conditions applicable to any electronic device of a specified type as defined by its published data, and should not be exceeded under the worst probable conditions.

These values are chosen by the device manufacturer to provide acceptable serviceability of the device, taking no responsibility for equipment variations, environmental variations, and the effects of changes in operating conditions due to variations in the characteristics of the device under consideration and of all other electronic devices in the equipment.

The equipment manufacturer should design so that, initially and throughout life, no absolute maximum value for the intended service is exceeded with any device under the worst probable operating conditions with respect to supply voltage variation, equipment components spread and variation, equipment control adjustment, load variations, signal variation, environmental conditions, and spread or variations in characteristics of the device under consideration and of all other electronic devices in the equipment.

4.1.2 Design-maximum rating system. Design-maximum ratings are limiting values of operating and environmental conditions applicable to a bogey electronic device\* of a specified type as defined by its published data, and should not be exceeded under the worst probable conditions.

These values are chosen by the device manufacturer to provide acceptable serviceability of the device, taking responsibility for the effects of changes in operating conditions due to variations in the characteristics of the electronic device under consideration.

The equipment manufacturer should design so that, initially and throughout life, no design-maximum value for the intended service is exceeded with a bogey device under the worst probable operating conditions with respect to supply-voltage variation, equipment component variation, variation in characteristics of all other devices in the equipment, equipment control adjustment, load variation, signal variation and environmental conditions.

4.1.3 Design-centre rating system. Design-centre ratings are limiting values of operating and environmental conditions applicable to a bogey electronic device\* of a specified type as defined by its published data, and should not be exceeded under average conditions.

Note \*. A bogey tube is a tube whose characteristics have the published nominal values for the type. A bogey tube for any particular application can be obtained by considering only those characteristics which are directly related to the application.

---

---

These values are chosen by the device manufacturer to provide acceptable serviceability of the device in average applications, taking responsibility for normal changes in operating conditions due to rated supply-voltage variation, equipment component spread and variation, equipment control adjustment, load variation, signal variation, environmental conditions, and variations or spread in the characteristics of all electronic devices.

The equipment manufacturer should design so that, initially, no design-centre value for the intended service is exceeded with a bogey electronic device \* in equipment operating at the stated normal supply-voltage.

- 4.2 If the tube data specify limiting values according to more than one rating system the circuit has to be designed so that none of these limiting values is exceeded under the relevant conditions.
- 4.3 In addition to the limiting values given in the individual data sheets the directives in the following paragraphs should be observed.

## 5. ELECTRODE VOLTAGES

5.1 All electrode voltages are given with respect to cathode.

5.2 Two limiting values of electrode voltage are given

a)  $V_{a0}$ ,  $V_{g20}$  etc.

These values are continuously permitted with cold cathode. They are also permitted as peak voltage during operation when a D.C. voltage in combination with a superimposed A.C. voltage is present at the electrode provided that the peak value coincides with approx. zero electrode current.

b)  $V_a$ ,  $V_{g2}$  etc.

These values are D.C. components of the electrode voltages and are continuously permitted.

In circuits with automatic gain control the D.C. component may exceed the published limiting value with 20% provided that the increase of voltage results solely from the a.g.c. action and that maximum voltage coincides with approximately zero electrode current.

Proper functioning of the tubes at supply voltages lower than 50 volts cannot be guaranteed if these values are not quoted under the operating characteristics. Unless otherwise stated all values refer to positive voltages.

Floating electrodes. All tube electrodes should have a D.C. connection to the cathode (no floating electrodes).

## 6. ELECTRODE CURRENT

The limiting values  $I_a$ ,  $I_{g2}$ ,  $I_k$  etc. are the D.C. components of the electrode currents averaged over any 50 ms period.

If no specific pulse ratings apply, a peak value of three times  $I_a$ ,  $I_{g2}$ ,  $I_k$  etc. is permitted for maximum 25 ms.

---

See note on previous page.

---

---

Spread and variation in electrode currents should be restricted so that with nominal tubes the specified design centre limiting values are not exceeded by more than 10% under the worst probable conditions.

## 7. ELECTRODE DISSIPATION

The limiting values  $W_a$ ,  $W_{g_2}$  etc. are the average values, obtained by averaging over any 1 s period.

- 7.1 If not otherwise indicated the quoted operating conditions for audio output tubes are permitted only with speech and music signals.

When for power output tubes a limiting value  $W_{g_2p}$  is stated this value applies only in the case of speech and music drive and it should not be exceeded when measured with a sinusoidal signal and at maximum output.

With class B operation and speech and music excitation the quoted limiting value of anode dissipation is allowed to be exceeded by max. 10% if measured with a sinusoidal signal at 2/3 of maximum drive.

When the operating conditions differ from those stated a non-decoupled series resistor of 0.5 to 1 k $\Omega$  may be required to avoid exceeding the limiting values of screen grid dissipation.

When load values vary during operation care should be taken that the limiting values of  $W_a$  or  $W_{g_2}$  are not exceeded.

Spread and variation in the electrode dissipation of audio output tubes should be restricted so that with bogey tubes the specified design centre limiting values are not exceeded by more than 20% under the worst probable conditions.

- 7.2 For all other types the quoted design centre limits for the electrode dissipations should not be exceeded by more than 15% with bogey tubes under the worst probable conditions unless otherwise stated in the relevant data sheets.

## 8. HEATER CIRCUIT

Any deviation from the nominal heater voltage (in case of parallel connection) or from the nominal heater current (in case of series connection) has a detrimental effect on tube performance and life, and should therefore be kept at a minimum. Such deviations may be caused by:

- a) Mains voltage fluctuations.
- b) Spread in the characteristics of components such as transformers, resistors, capacitors etc.

Designers of heater circuits are strongly recommended to bear this in mind when dealing with equipment to be used in areas where the actual mains voltage is likely to differ from the nominal value.

### 8.1 Parallel connection

The maximum deviation of the heater voltage should not exceed  $\pm 15\%$  (design max. value).

This condition will be fulfilled when the mains voltage fluctuates by  $\pm 10\%$  and a ordinary transformer (see below) is used.

### 8.2 Series connection

The maximum deviation of the heater current should not exceed  $\pm 8\%$  (design max. value).

When a small number of tubes with large differences in the heater voltage is used in series connection combined with a series resistor or a series capacitor, the maximum permitted deviation of the heater current may be exceeded.

To avoid this, certain restrictions must be imposed on the composition of the heater chain; the maximum part of the supply voltage that can be eliminated, and the tolerances of the voltage dropper in series with the heaters.

A number of circuits for  $I_f = 300 \text{ mA}$  will be described in detail below.

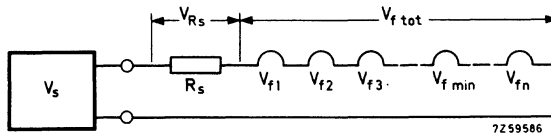

$V_s$  = source voltage (mains voltage or mains voltage stepped down via a transformer)

$V_{R_s}$  = voltage drop over series resistor

$V_{f \text{ tot.}}$  =  $V_{f1} + V_{f2} + V_{f3} \dots \dots \dots + V_{f \text{ min.}} + \dots \dots \dots V_{fn}$ .

$V_{f \text{ min.}}$  = lowest individual heater voltage of all tubes in the chain

$R_s$  = series resistor

### Voltage source

The following spreads have been taken into account for the source voltage:

- Mains voltage spread  $\pm 10\%$  either or not combined with the voltage spread caused by a transformer with a permanent deviation from the nominal value of  $\pm 1\%$  and with a spread of  $\pm 2\%$  (ordinary, well made transformer).

---

---

The following circuits are allowed:

8.2.1 Supply directly from a voltage source ( $V_S = V_{ftot.}$ )

- No restrictions.

8.2.2 Supply from a voltage source via a 5% series resistor ( $V_S = V_{RS} + V_{ftot.}$ )

a. One single tube: permitted if  $\frac{V_{RS}}{V_{ftot.}} \leq 2$

b. Heater chain consisting of 2 or more tubes:

the maximum permitted ratio  $\frac{V_{RS}}{V_{ftot.}}$  can be read from diagram number 1 as follows:

Determine  $\frac{V_{fmin.}}{V_{ftot.}}$  of the heater chain. Draw a vertical line through the corresponding point in the diagram. Draw a horizontal line through the point of intersection of this vertical line with the line which indicates the total number of tubes in the chain. The point of intersection of this horizontal line with the vertical axis gives the maximum permitted ratio between the series resistor and the sum of the heater voltages of all tubes in the chain.

8.2.3 Supply from a voltage source via a series diode ( $\frac{V_S}{\sqrt{2}} = V_{ftot.}$ )

- No restrictions.

8.2.4 Supply from a voltage source via a series diode and a series resistor

$$\left(\frac{V_S}{\sqrt{2}}\right) = V_{ftot.} + V_{RS}$$

In the above formula  $V_{ftot.}$  and  $V_{RS}$  are RMS values and the maximum permitted ratio  $\frac{V_{RS}}{V_{ftot.}}$  can be read from diagram number 1 (see 8.2.2).

For calculation of  $R_S$  divide the required  $V_{RS}$  (RMS) by the nominal heater current:  $R_S = \frac{V_{RS}}{0.3}$

Remark to 8.2.3 and 8.2.4:

When series diodes are applied, the D.C. component of the resulting heater voltage should preferably be negative with respect to the cathodes of the tubes.

### 8.2.5 Supply from a voltage source via a series capacitor

a. One single 300 mA tube; permitted if

$$\frac{V_{ftot.}}{V_s} \geq 0.50 \quad \text{when 5\% paper capacitors are applied.}$$

b.  $\frac{V_{ftot.}}{V_s} \geq 0.70$  when 10% metallized polycarbonate capacitors are applied.

c. Heater chain consisting of 2 tubes or more; permitted if  $\frac{V_{ftot.}}{V_s}$

$$\frac{V_{ftot.}}{V_s} \geq 0.6 \quad \text{when 5\% paper capacitors are applied.}$$

$$\frac{V_{ftot.}}{V_s} \geq 0.8 \quad \text{when 10\% metallized polycarbonate capacitors are applied.}$$

### 8.3 Stand-by (instant-on circuits)

In order to maintain reliability during life, it is recommended to reduce the heater voltage of the tubes during stand-by operation to 75% of the nominal value.

#### Note

If other designs for the heater supply circuit are wanted than the configurations described above it is strongly recommended to contact the tube manufacturer.

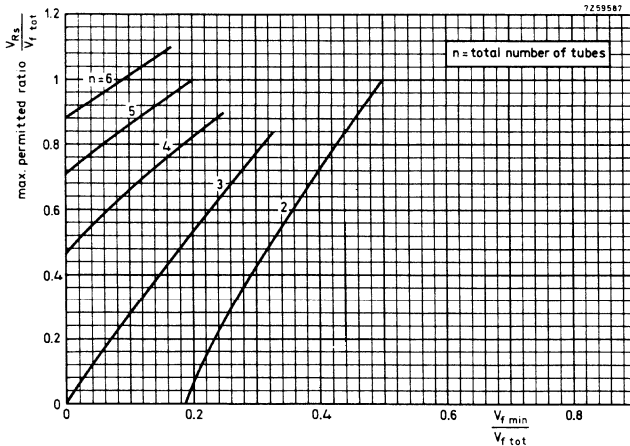

Diagram No. 1



---

---

## 9. HEATER-TO-CATHODE CIRCUIT

The published limiting values of  $V_{kf}$  apply to the positive and negative D.C. component of the voltage between the cathode and any of the heater terminals.

The limiting peak value is twice the rated D.C. value with a maximum of 315 V.

In stating these values figures only the risk of breakdown has been considered. No conclusions with respect to hum should be drawn from them.

To minimize the influence of variation and spread in the leakage current between heater and cathode the resistance of the external heater to cathode circuit should not exceed 20 k $\Omega$ .

However, when the D.C. value of  $V_{kf}$  never drops below three times the RMS value of the heater voltage a resistor of maximum 220 k $\Omega$  may be connected between heater and cathode provided that the hum voltage which may develop across the cathode resistor is acceptable for the application considered.

An interruption of the D.C. connection between cathode and earth or heater and earth may introduce heater-cathode breakdown and should be avoided.

## 10. SUPPRESSOR GRID CIRCUIT

The suppressor grid should normally be connected to the cathode; any series resistance in the suppressor grid lead should not exceed a value of 50 k $\Omega$ . The suppressor grid should not be used as a control grid unless specific recommendations are made in the data sheets. Where the suppressor grid is so used, care should be taken not to exceed the maximum screen-grid dissipation. When a tube is connected as a triode, the suppressor grid should be connected directly to the cathode, except where other recommendations are given in the data sheets. If the circuit is such that the suppressor grid is liable to be driven positive, it is recommended to consult the tube manufacturer.

## 11. CONTROL GRID CIRCUIT

In the interest of low hum and noise the resistance in the control grid circuit should be as low as possible.

The limiting value of the grid resistance given in the data sheets is so chosen that during the tube life the negative grid current which may occur will not result in unacceptable tube operation.

If only the limiting value of the resistance for fixed bias operation is given and stabilizing elements are used in the circuit, this limiting value may be multiplied by the D.C. feedback factor obtained by these stabilizing elements; the maximum limiting value should not exceed 20 M $\Omega$ .

## 12. CAPACITANCES

All data have been measured according to I.E.C. Publication 100

---

---

### 13. PROTECTIVE RESISTORS FOR MAINS RECTIFYING TUBES

To restrict the peak value of cathode current in a mains rectifying tube the ohmic resistance ( $R_t$ ) in series with the anode should not be less than that specified in the data sheet.

When the anode supply voltage is obtained from a transformer the value of the resistance to be added in each anode lead should be calculated from the following formula:

$$R_t = R_s + n^2 R_p + R_1.$$

In case of half-wave rectification

$R_t$  = the required protective resistance

$R_s$  = the ohmic resistance of the secondary coil

$n$  = the transformer ratio

$R_p$  = the ohmic resistance of the primary coil

$R_1$  = resistance that must be added

In case of full-wave rectification

$R_t$  = the required protective resistance per anode

$R_s$  = ohmic resistance of half the secondary coil

$n$  = transformer ratio between primary and half the secondary coil

$R_p$  = ohmic resistance of the primary coil

$R_1$  = resistance to be added in each anode lead.

When an auto transformer is applied it should be taken into account that the transformer winding is partly short-circuited by the mains.

When a filter input capacitor is applied the power dissipation in  $R_t$  is supplemented by the contribution of the ripple current up to three times the value produced by the D.C. component of current.

### 14. LIFE

Optimum life performance is ensured if the tube is operated according to the published "Operating conditions". Spread and variation of operating conditions should be limited as much as possible.

### 15. HUM

15.1 When the heater supply is obtained from the mains voltage the cathode current may be modulated by the A.C. mains frequency.

This modulation, resulting in hum, may be caused by capacitive or leakage currents between the heater and the tube electrodes, by the magnetic field of the heater or by external fields.

15.2 The following measures can be taken to reduce hum.

#### Cathode hum

Keep the A.C. voltage between cathode and heater as small as possible; with series operation insert the most critical tube at the earthed side of the heater chain and with parallel operation connect the electrical centre of the heater to earth.

---

---

Do not include the impedance between cathode and heater in an R.F. circuit. If this cannot be avoided and the cathode must be connected to a **tapping** of a tuned circuit, choose the highest practicable tuning capacitance in order to reduce the influence of possible variations in circuit capacitance. This applies especially to oscillator circuits where variations in the capacitance between cathode and heater may lead to modulation hum.

Decouple the cathode resistance as far as possible.

Where negative feedback is applied, take the non-decoupled part as small as possible.

#### Control grid hum

Keep the A.C. voltage between cathode and heater as small as possible. Do not use idle socket contacts in the proximity of the control grid contact as anchoring points for joints connected to 50 Hz as this may cause hum due to leakage or capacitance in the tube socket.

Keep the impedance at the mains frequency in the control grid lead as small as possible.

- 15.3 For tubes mainly intended for use in broadcast receivers the value of  $Z_{g1}$  at mains frequency is so chosen that the hum voltage will be -60 dB (design centre value) with respect to the input voltage for 50 mW output power.

The hum voltage in this case is measured behind a filter, the characteristic, of which agrees with the C.C.I.R. aural sensitivity curve (see graph on next page).

For tubes mainly intended for use in audio equipment the value of  $Z_{g1}$  is so chosen that the level of hum voltage, measured with a filter linear up to 500 Hz, is -60 dB with respect to the input voltage for maximum output power. To obtain these values the centre of parallel-connected heaters should be earthed whereas with series-connected heaters the value of  $V_{kf}$ , permitted in connection with hum, should not be exceeded; when a cathode resistor is used, it should be decoupled by a capacitor of at least 100  $\mu$ F.

It should be realized that, although the tubes may meet the requirement of a -60 dB hum level, the total hum level of the circuitry stage under consideration may be higher owing to imperfect circuitry (magnetic hum induced by transformers and smoothing chokes; unsatisfactory smoothing of the rectified voltage, etc.).

For several R.F. and I.F. types a curve has been published which shows, as a function of the transconductance, the hum voltage ( $V_i$ ) on the control-grid which causes a modulation hum of 1%.

The published limiting value of  $V_{kf}$  is the maximum permissible value up to which there will be no danger of breakdown between cathode and heater, and it does not give information about the resulting hum level.

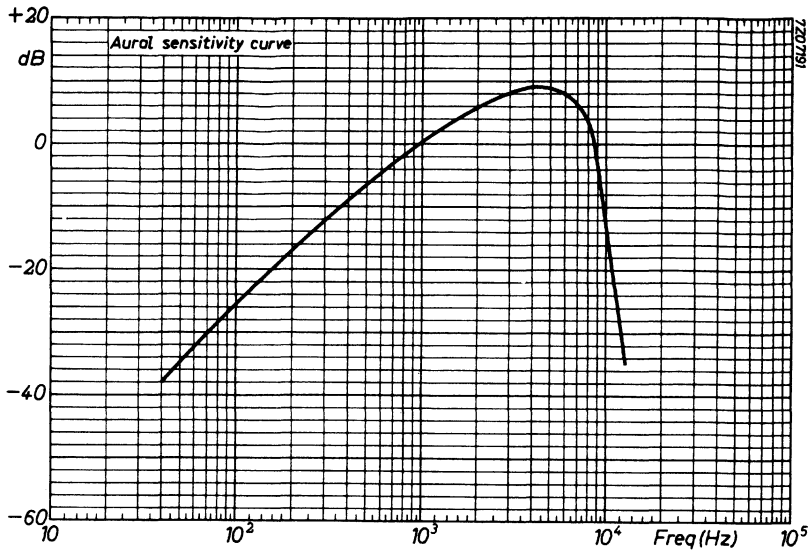

## 16. MICROPHONY

Whenever a tube is subjected to vibration, caused by e.g. a loudspeaker, motor, switch etc., some disturbance in the output of the tube occurs. The effect of this disturbance will depend on the individual application. The published data of various tube types make reference to the microphonic sensitivity and this should be noted when a tube is chosen for a specific application.

Where the effects of microphony are found to be objectionable, special steps may have to be taken to reduce the vibration reaching the tube. The chassis itself may show wide variations in amplitude of vibration over its area, due to resonances; therefore favourable location of the tube, or local strengthening of the chassis, may appreciably reduce microphony.

The maximum peak acceleration to which the tube may be subjected under the most unfavourable conditions is 1.5 g at frequencies < 600 Hz and 0.2 g at frequencies > 600 Hz. However, tubes should not be subjected to the maximum acceleration at a given frequency for a long period of time. In case the actual acceleration is higher than these values, difficulties with regard to microphony may be expected.

Warning: It should be noted that excessive mechanical vibration may result in the destruction of the internal tube structure.

---

---

## 17. ENVIRONMENTAL CONDITIONS

1. Atmospheric pressure. Ratings apply to operation at normal atmospheric pressure at altitudes below 3000 m.

It is advised to consult the tube manufacturer if tubes have to be operated at lower pressures.

2. Thermal considerations. The bulb and the base temperature are defined as the highest temperature at any place on the bulb or the base. The base temperature should not exceed 165 °C.

Used in practical circuits and under design centre conditions the bulb temperature of a tube should not exceed by more than 30 °C that temperature which would be attained if the tube were operated at its maximum ratings in free air at a room temperature of 20 °C.

If, for instance, the bulb temperature of a certain type of tube operating in free air at maximum ratings is shown to be 200 °C, it is permissible to use this tube in equipment where the bulb attains a temperature of 230 °C (thus at an excess of 30 °C). In practice this means that the "ambient" temperature in the equipment may rise above room temperature by about twice 30 °C and thus may attain a value of 80 °C.

When a tube runs particularly hot this increase of 30 °C is not permissible; the design maximum should then be 250 °C unless otherwise stated in the relevant data sheets.

When the maximum permitted base or bulb temperature is exceeded, the tube reliability during life may deteriorate. Cooling should therefore always be adequate; it may be obtained by convection, radiation or conduction. To make it most efficient a free circulation of air should be assured around the tube and the temperature of neighbouring bodies should be low. These neighbouring bodies should preferably approach a perfect black body.

The design of screening or retaining devices should also be such that the reflection of heat back to the bulb must be minimized. In some cases it may be necessary to reduce the electrode dissipation.

Heat dissipating shields have the property to reduce the hot-spot temperature at the tube envelope. However, this is generally accompanied by a rise in base temperature whereas also the normal sublimation pattern inside the tube may be drastically disturbed. For this reason extreme care should be exercised when applying these devices.

3. High Voltage insulation. To avoid insulation breakdown due to ionization or tracking at high electrode voltages adequate ventilation is required.

High voltage terminals should not have sharp or pointed edges.

---

---

## 18. MOUNTING AND WIRING

1. Mounting position. Unless otherwise specified, a tube may be mounted in any position.
2. Pins and sockets. Many tube types employ semi-rigid pins.

To ensure that these pins are straight before insertion into the tube socket use may be made of a pin straightening tool. It is recommended both in wired and in printed circuits to use sockets in which the contact springs are reasonably flexible. Too stiff wiring may hold the contacts out of position in such a way that the tube base is damaged upon insertion. To avoid this the use of a wiring jig is recommended. The dimensions of the wiring jig shall be in conformity with the nominal base dimensions specified in this Handbook.

No connections should be made to a pin marked i.c.

The sockets used shall comply with the following:

The insertion and withdrawal forces of sockets shall be checked before any previous gauging or sizing. The sockets shall be capable of accepting and having withdrawn from them the insertion and withdrawal force gauge\* within the force limits specified below. These tests shall be made with a test jig.

Socket compatible with small button miniature 7 pin base (IEC 67-I-10a)

|                       |                |
|-----------------------|----------------|
| max. insertion force  | 72 N (7.2 kgf) |
| min. withdrawal force | 12 N (1.2 kgf) |

Socket compatible with small button noval 9 pin base (IEC 67-I-12a)

|                       |                   |
|-----------------------|-------------------|
| max. insertion force  | 91 N (9.1 kgf)    |
| min. withdrawal force | 13.5 N (1.35 kgf) |

Socket compatible with small button decal 10 pin base (IEC 67-I-41a)

|                       |                   |
|-----------------------|-------------------|
| max. insertion force  | 91 N (9.1 kgf)    |
| min. withdrawal force | 13.5 N (1.35 kgf) |

Socket compatible with magnoval base (IEC 67-I-36a)

|                       |                   |
|-----------------------|-------------------|
| max. insertion force  | 91 N (9.1 kgf)    |
| min. withdrawal force | 13.5 N (1.35 kgf) |

3. Retaining devices. When measures are required to prevent a tube from being shaken out of the socket a retaining device may be used. Care should then be taken to avoid the maximum permitted bulb temperature being exceeded.

---

\* Described in I.E.C. Publication 149.

---

## **DIMENSIONS OF BASES**

In the outline drawings of bases given below, some main dimensions (in mm) only have been given.

For further details is referred to IEC publication 67.

The page number on which the outline drawing can be found in this publication is therefore given for each base type.

MINIATURE 7-PIN BASE  
(IEC 67-1-10a)

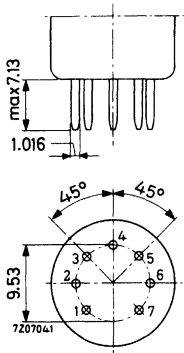

RIMLOCK BASE  
(IEC 67-1-11b)

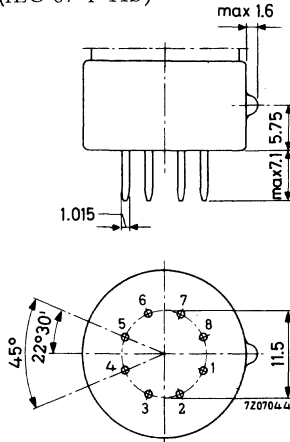

OCTAL BASE  
(IEC 67-1-5a)

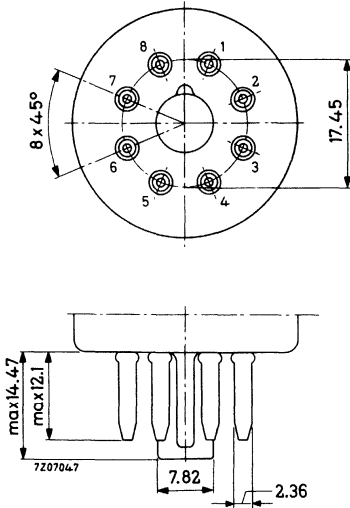

NEO EIGHTAR BASE  
(IEC 67-1-31a)

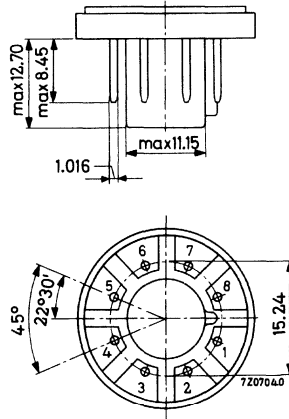



NOVAL BASE  
(IEC 67-I-12a)

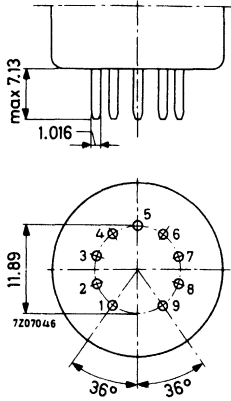

MAGNOVAL BASE  
(IEC 67-I-36a)

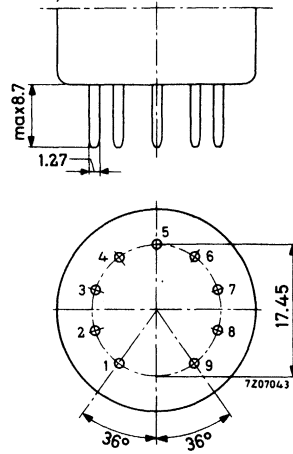

DECAL BASE  
(IEC 67-I-41a)

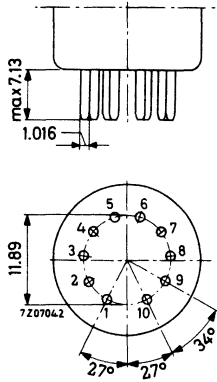

DUODECAL BASE  
(IEC 67-I-17a)

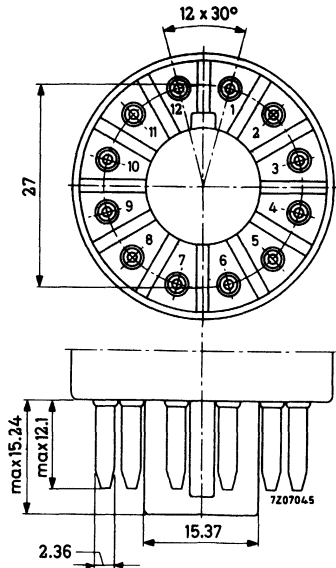

## DIMENSIONS OF CAPS

The dimensions for the drawings of top caps have been given in mm. The dimensions A, B and C, which are those necessary to ensure compatibility between cap and corresponding connector are in accordance with IEC publication 67, page 67-III-1 a.

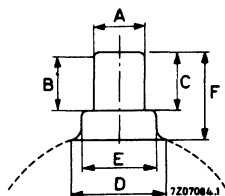

Type 1

| ref. | min. | nom.  | max.                |
|------|------|-------|---------------------|
| A    | 6.23 | 6.35  | 6.47                |
| B    | 5.1  |       |                     |
| C    |      | 7.14  | 8.89 <sup>1)</sup>  |
| D    |      |       | 11.5                |
| E    |      | 9.15  |                     |
| F    |      | 10.31 | 11.43 <sup>1)</sup> |

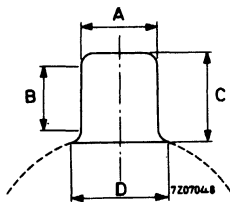

Type 2

|   |      |       |                     |
|---|------|-------|---------------------|
| A | 9.02 | 9.14  | 9.27                |
| B | 7.7  |       |                     |
| C |      | 10.31 | 11.43 <sup>1)</sup> |
| D |      |       | 11.5                |

<sup>1)</sup> Without solder. On finished article an increase of 0,5 mm is allowed on this dimension for solder.

## Receiving Tubes



## SINGLE ANODE E.H.T. RECTIFYING TUBE

Single anode high vacuum rectifying tube intended for use in portable T.V. receivers.

**HEATING:** Indirect; parallel supply

Heater voltage

$$\frac{V_f}{I_f} = \frac{1.4 \text{ V}}{550 \text{ mA}}$$

Heater current

$$I_f = 550 \text{ mA}$$

### DIMENSIONS AND CONNECTIONS

Dimensions in mm

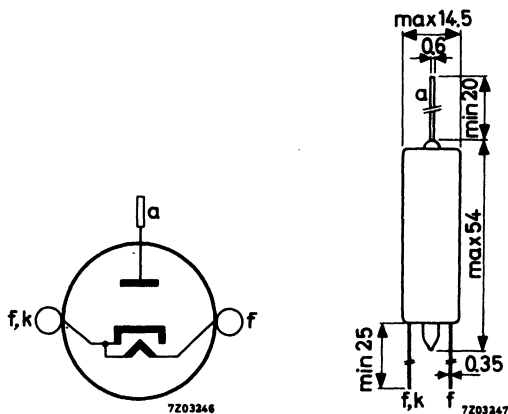

The tube has flexible leads, which must not be bent nearer than 10 mm to the tube bottom.

The leads should not be soldered nearer than 1.5 mm to the seal.

### CAPACITANCE

Anode to all

$$C_a = 0.8 \text{ pF}$$

### TYPICAL CHARACTERISTICS

Anode voltage

$$V_a = 100 \text{ V}$$

Anode current

$$I_a = 13 \text{ mA}$$

**LIMITING VALUES** (Design centre rating system, unless otherwise specified)

|  |            |      |                     |
|--|------------|------|---------------------|
| Anode voltage, negative peak                     | $-V_{ap}$  | max. | 15 kV               |
| Anode voltage, negative peak (abs. max.)         | $-V_{ap}$  | max. | 18 kV               |
| Anode current, average                           | $I_a$      | max. | 350 $\mu A$         |
| Anode current, peak                              | $I_{ap}$   | max. | 40 mA <sup>1)</sup> |
| Filter input capacitance                         | $C_{filt}$ | max. | 2000 pF             |
| Heater voltage ( $I_a < 200 \mu A$ ) (abs. max.) | $V_f$      | max. | 1.6 V               |
| Heater voltage ( $I_a > 200 \mu A$ ) (abs. max.) | $V_f$      | min. | 1.3 V               |

<sup>1)</sup> Max. duration is 10 % of a line-scanning cycle, but max. 10  $\mu sec$ .

## SINGLE ANODE E.H.T. RECTIFYING TUBES

High-vacuum single-anode rectifying tubes for high tension in television receivers (E.H.T. supply from the line time base).

The DY86 and DY87 are equivalent except for the DY87 having a chemically treated envelope which avoids flash-over under conditions of high humidity and low atmospheric pressure (45 cm Hg).

**HEATING:** Indirect by A.C. or D.C.; parallel supply

|                |       |        |
|----------------|-------|--------|
| Heater voltage | $V_f$ | 1.4 V  |
| Heater current | $I_f$ | 550 mA |

When the heater is to be operated on R.F. or flyback pulses, the heater voltage can be adjusted to 1.4 V e.g. by measurement with a thermocouple.

### Tolerances of $V_f$

#### a. As E.H.T. rectifier in television receivers

The heater voltage should be adjusted to its nominal value at a D.C. output current of  $200\mu A$ . At an increase of the D.C. output current to 400 to  $600\mu A$  which can incidentally occur during operation the decrease of the heater voltage may amount to max. 15 %. These requirements hold for nominal mains voltage and full horizontal scanning of the picture tube. If the picture width control is such that also the heater voltage of the E.H.T. diode is influenced, the influence of this control must be kept within the 15 % limit indicated above.

#### b. For all other applications the limits for the heater voltage are as given in the application directions in front of this section.

**DIMENSIONS AND CONNECTIONS**

Dimensions in mm

Base: NOVAL

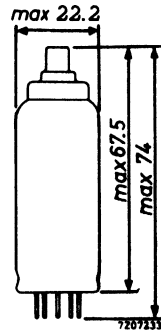
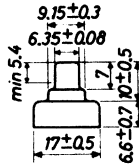
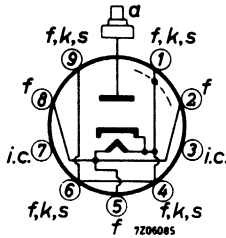

**REMARKS**

- a. Pins 1, 4, 6 and 9 can be used for fixing an anti-corona ring.
- b. Circuit elements having the same potential as the heater (e.g. a series resistor) may be connected to pins 3 and 7. These pins must never be earthed.
- c. If the tube operates at high values of  $V_{a\text{ invp}}$  and/or under conditions of high relative humidity or low pressure the metal top-cap should get an insulating cover to avoid corona phenomena.

**CAPACITANCES (without external shield)**

Anode to all  $C_a$  1.55 pF

**OPERATING CHARACTERISTICS**

Output current  $I_o$  0.15 mA  
 Output voltage  $V_o$  18 kV



**LIMITING VALUES** (Design centre rating system unless otherwise stated)

|   |                              |                           |
|---|------------------------------|---------------------------|
| Output voltage                          | $V_o$                        | max. 18 kV                |
| Peak inverse voltage                    | $V_{a\text{ inv}p}$          | max. 22 kV <sup>1)</sup>  |
| Peak inverse voltage<br>(Absolute max.) | $V_{a\text{ inv}p}$          | max. 27 kV <sup>1)</sup>  |
| Peak inverse voltage without current    | $V_{a\text{ inv}p}(I_o = 0)$ | max. 24 kV <sup>1)</sup>  |
| Output current                          | $I_o$                        | max. 0.5 mA <sup>2)</sup> |
| Peak output current                     | $I_{a_p}$                    | max. 40 mA <sup>3)</sup>  |
| Filter input capacitance                | $C_{\text{filt}}$            | max. 2000 pF              |

<sup>1)</sup> Maximum pulse duration 22 % of a line scanning cycle with a maximum of 18  $\mu\text{sec}$ .

The negative peak anode voltage due to ringing in the line-output transformer must be taken into account. The ratio between this negative peak value and the positive D.C. voltage can be about 1:4.5.

<sup>2)</sup> During short periods as in television service  $I_o = \text{max. } 0.8 \text{ mA}$ .

<sup>3)</sup> Maximum pulse duration 10 % of a line scanning cycle with a maximum of 10  $\mu\text{sec}$ .

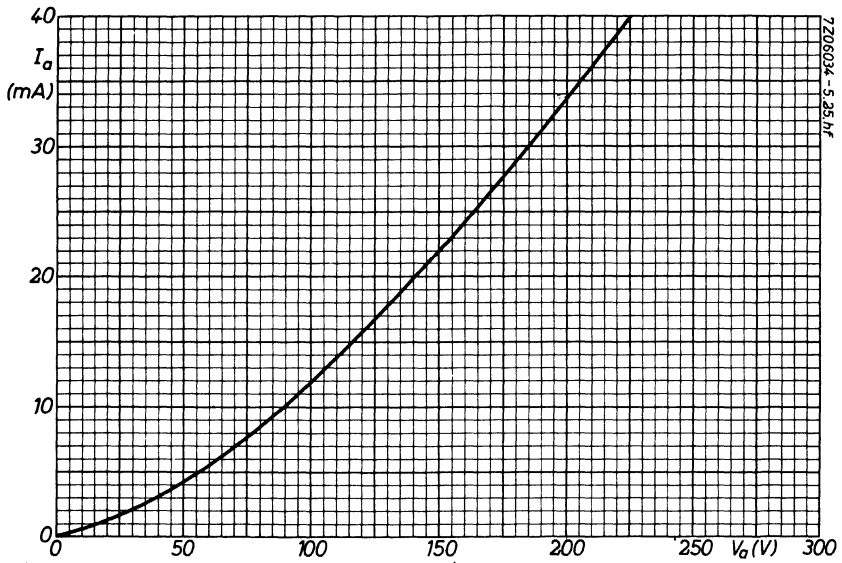

## E.H.T. RECTIFYING TUBE

High-vacuum single-anode rectifying tube for high tension in television receivers (E.H.T. supply from the line time base)

The DY802 has a chemically treated envelope which avoids flash-over under conditions of high humidity and low atmospheric pressure (45 cm Hg).

**HEATING:** Indirect by A.C. or D.C.; parallel supply

|                |       |        |
|----------------|-------|--------|
| Heater voltage | $V_f$ | 1.4 V  |
| Heater current | $I_f$ | 600 mA |

### Tolerances of $V_f$

#### a. As E.H.T. rectifier in television receivers

The heater voltage should be adjusted to its nominal value at a D.C. output current of  $200 \mu A$ . At an increase of the D.C. output current to  $400-800 \mu A$  which can incidentally occur during operation the decrease of the heater voltage may amount to max. 15%. These requirements hold for nominal mains voltage and full horizontal scanning of the picture tube. If the picture width control is such that also the heater voltage of the E.H.T. diode is influenced, the influence of this control must be kept within the 15% limit indicated above.

#### b. For all other applications the limits for the heater voltage are as given in the application directions.

## DIMENSIONS AND CONNECTIONS

Dimensions in mm

Base: Noval

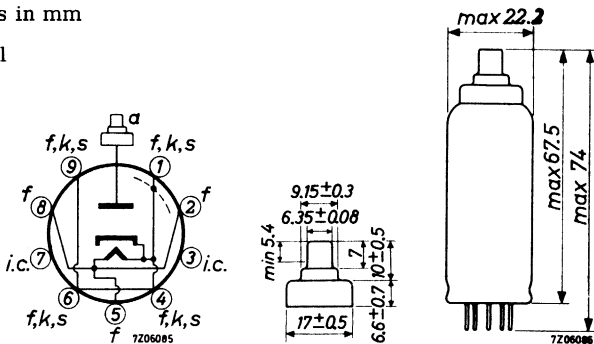

**REMARKS**

- a. Pins 1, 4, 6 and 9 can be used for fixing an anti-corona ring.
- b. Circuit elements having the same potential as the heater (e.g. a series resistor) may be connected to pins 3 and 7. These pins must never be earthed.
- c. If the tube operates a high values of  $V_{a\text{inv}p}$  and/or under conditions of high relative humidity or low pressure the metal top-cap should get an insulating cover to avoid corona phenomena.

**CAPACITANCE**

Anode to all  $C_a$  1.0 pF

**OPERATING CHARACTERISTICS**

Output current  $I_o$  200  $\mu A$   
 Output voltage  $V_o$  20 kV

**LIMITING VALUES** (Design centre rating system unless otherwise stated)

|                                  |                    |      |                           |
|----------------------------------|--------------------|------|---------------------------|
| Output voltage                   | $V_o$              | max. | 20 kV                     |
| Peak inverse voltage             | $V_{a\text{inv}p}$ | max. | 25 kV <sup>1)</sup>       |
| Peak inverse voltage (Abs. max.) | $V_{a\text{inv}p}$ | max. | 30 kV <sup>1)</sup>       |
| Output current, average          | $I_o$              | max. | 500 $\mu A$ <sup>2)</sup> |
| peak                             | $I_{op}$           | max. | 50 mA                     |
| Filter input capacitance         | $C_{\text{filt}}$  | max. | 3000 pF                   |

<sup>1)</sup> Max. duration 22% of a line scanning cycle and maximum 18  $\mu s$ .  
 The negative peak anode voltage due to ringing in the line-output transformer must be taken into account.

<sup>2)</sup> During short periods as in TV operation  $I_o = \text{max. } 800 \mu A$ .

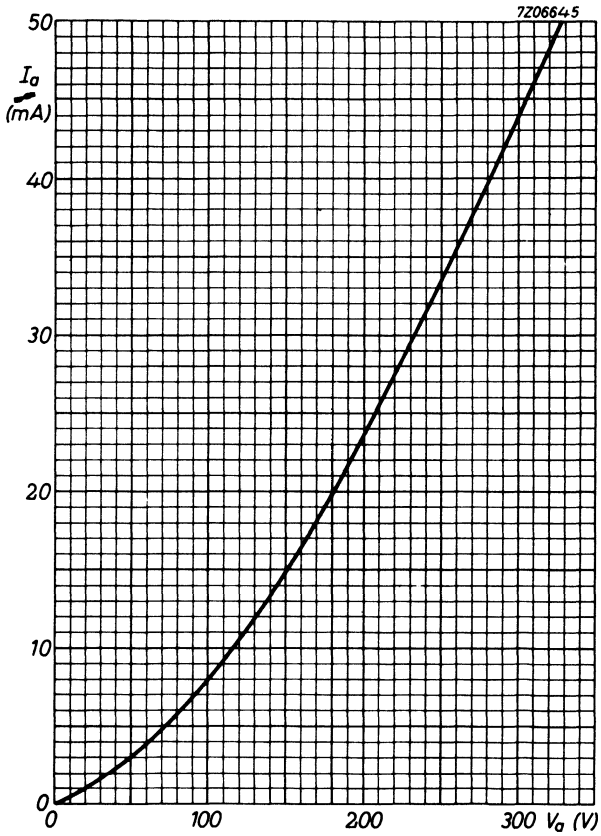



## DOUBLE DIODE

Double diode with separate cathodes.

| QUICK REFERENCE DATA     |          |     |                  |
|--------------------------|----------|-----|------------------|
| A. C. supply voltage     | $V_{TR}$ | 150 | V <sub>RMS</sub> |
| D. C. current per system | $I_o$    | 9   | mA               |

**HEATING:** Indirect by A. C. or D. C.; series or parallel supply

|                |       |     |    |
|----------------|-------|-----|----|
| Heater voltage | $V_f$ | 6.3 | V  |
| Heater current | $I_f$ | 300 | mA |

### DIMENSIONS AND CONNECTIONS

Dimensions in mm

Base: Miniature

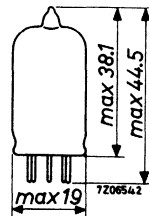
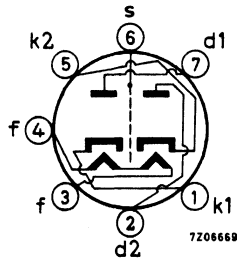

### CAPACITANCES

|                            |            | With external shield | Without external shield |
|----------------------------|------------|----------------------|-------------------------|
| Diode No. 1 to all         | $C_{d1}$   | 3.0                  | 2.5 pF                  |
| Diode No. 2 to all         | $C_{d2}$   | 3.0                  | 2.5 pF                  |
| Diode No. 1 to diode No. 2 | $C_{d1d2}$ | max. 0.026           | max. 0.068 pF           |
| Cathode No. 1 to all       | $C_{k1}$   | 3.4                  | 3.4 pF                  |
| Cathode No. 2 to all       | $C_{k2}$   | 3.4                  | 3.4 pF                  |

## LIMITING VALUES Design centre rating system. (Each system)

|   |                    |                    |
|---|--------------------|--------------------|
| Diode voltage, negative peak            | $-V_{d_p}$         | max. 420 V         |
| Diode current                           | $I_d$              | max. 9 mA          |
| Diode current, peak                     | $I_{d_p}$          | max. 54 mA         |
| Cathode to heater voltage peak (k neg)  | $V_{kf_p}$ (k neg) | max. 150 V         |
| Cathode to heater voltage, peak (k pos) | $V_{kf_p}$ (k pos) | max. 330 V         |
|   | D. C. component    | max. 200 V         |
|   | A. C. component    | max. 165 $V_{RMS}$ |

### As half wave rectifier

|   |                    |                    |
|---|--------------------|--------------------|
| A. C. supply voltage                    | $V_{tr}$           | max. 150 $V_{RMS}$ |
| D. C. current                           | $I_o$              | max. 9 mA          |
| Input capacitor of smoothing filter     | $C_{filt}$         | max. 8 $\mu F$     |
| Protecting resistance                   | $R_t$              | min. 300 $\Omega$  |
| Cathode to heater voltage, peak (k pos) | $V_{kf_p}$ (k pos) | max. 330 V         |
|   | D. C. component    | max. 200 V         |
|   | A. C. component    | max. 165 $V_{RMS}$ |

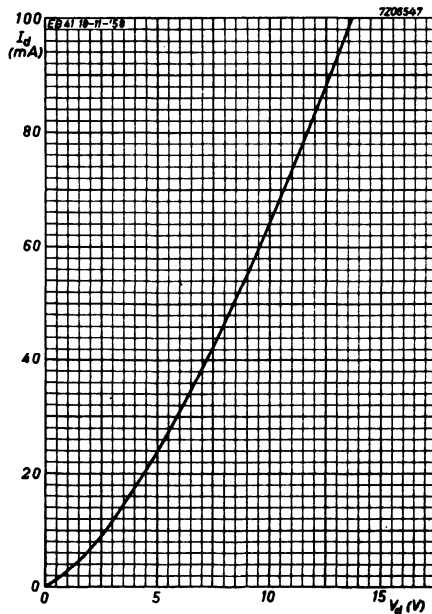



## TRIPLE DIODE-TRIODE

Triple diode-triode intended for F.M. and A.M. signal detection and A.F. signal amplification.

| QUICK REFERENCE DATA  |       |           |
|-----------------------|-------|-----------|
| <u>Triode section</u> |       |           |
| Anode current         | $I_a$ | 0.8 mA    |
| Transconductance      | S     | 1.45 mA/V |
| Amplification factor  | $\mu$ | 70 -      |

**HEATING:** Indirect by A.C. or D.C.; parallel supply

|                |       |        |
|----------------|-------|--------|
| Heater voltage | $V_f$ | 6.3 V  |
| Heater current | $I_f$ | 480 mA |

### DIMENSIONS AND CONNECTIONS

Dimensions in mm

Base: Noval

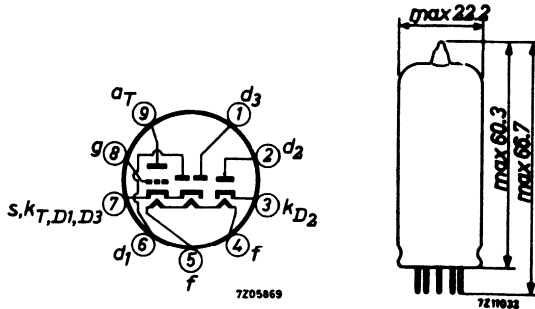

## CAPACITANCES

### Triode section

|                          |            |           |    |
|--------------------------|------------|-----------|----|
| Grid to all except anode | $C_{g(a)}$ | 1.9       | pF |
| Anode to all except grid | $C_{a(g)}$ | 1.4       | pF |
| Anode to grid            | $C_{ag}$   | 2.0       | pF |
| Grid to heater           | $C_{gf}$   | max. 0.04 | pF |

### Diode sections

|                             |             |           |    |
|-----------------------------|-------------|-----------|----|
| Diode No.1 to all           | $C_{d_1}$   | 0.8       | pF |
| Diode No.2 to all           | $C_{d_2}$   | 4.8       | pF |
| Diode No.3 to all           | $C_{d_3}$   | 4.8       | pF |
| Cathode ( $D_2$ ) to all    | $C_{kD_2}$  | 4.9       | pF |
| Diode No.1 to heater        | $C_{d_1f}$  | max. 0.25 | pF |
| Diode No.3 to heater        | $C_{d_3f}$  | max. 0.2  | pF |
| Cathode ( $D_2$ ) to heater | $C_{kD_2f}$ | 2.5       | pF |

### Between triode and diode sections

|                            |             |            |    |
|----------------------------|-------------|------------|----|
| Anode to diode No.1        | $C_{ad_1}$  | max. 0.12  | pF |
| Anode to diode No.3        | $C_{ad_3}$  | max. 0.1   | pF |
| Anode to cathode ( $D_2$ ) | $C_{akD_2}$ | max. 0.01  | pF |
| Grid to diode No.1         | $C_{gd_1}$  | max. 0.07  | pF |
| Grid to diode No.3         | $C_{gd_3}$  | max. 0.02  | pF |
| Grid to cathode ( $D_2$ )  | $C_{gkD_2}$ | max. 0.005 | pF |

## TYPICAL CHARACTERISTICS Triode section

|                      |       |      |     |            |
|----------------------|-------|------|-----|------------|
| Anode voltage        | $V_a$ | 100  | 250 | V          |
| Grid voltage         | $V_g$ | -1   | -3  | V          |
| Anode current        | $I_a$ | 0.8  | 1.0 | mA         |
| Transconductance     | $S$   | 1.45 | 1.4 | mA/V       |
| Amplification factor | $\mu$ | 70   | 70  | -          |
| Internal resistance  | $R_i$ | 48   | 50  | k $\Omega$ |

**OPERATING CHARACTERISTICS**

Triode section as RC coupled A.F. amplifier

Grid resistor  $R_g = 10 \text{ M}\Omega$

|                          |           |      |      |      |      |      |      |            |
|--------------------------|-----------|------|------|------|------|------|------|------------|
| Supply voltage           | $V_b$     | 250  | 250  | 250  | 200  | 200  | 200  | V          |
| Anode resistor           | $R_a$     | 220  | 100  | 47   | 220  | 100  | 47   | k $\Omega$ |
| Grid resistor next stage | $R_g'$    | 0.68 | 0.33 | 0.15 | 0.68 | 0.33 | 0.15 | M $\Omega$ |
| Anode current            | $I_a$     | 0.76 | 1.40 | 2.20 | 0.56 | 1.00 | 1.60 | mA         |
| Voltage gain             | $V_o/V_i$ | 54   | 47   | 36   | 53   | 44   | 34   | -          |

Distortion:

|  |                  |      |      |     |     |     |     |   |
|--|------------------|------|------|-----|-----|-----|-----|---|
| at output voltage $V_o = 3 \text{ V}_{\text{RMS}}$ | $d_{\text{tot}}$ | 0.2  | 0.25 | 0.3 | 0.3 | 0.4 | 0.5 | % |
| at output voltage $V_o = 5 \text{ V}_{\text{RMS}}$ | $d_{\text{tot}}$ | 0.25 | 0.5  | 0.6 | 0.4 | 0.6 | 0.9 | % |
| at output voltage $V_o = 8 \text{ V}_{\text{RMS}}$ | $d_{\text{tot}}$ | 0.6  | 0.8  | 1.0 | 0.9 | 1.0 | 1.5 | % |

|                          |           |      |      |      |      |      |      |            |
|--------------------------|-----------|------|------|------|------|------|------|------------|
| Supply voltage           | $V_b$     | 170  | 170  | 170  | 100  | 100  | 100  | V          |
| Anode resistor           | $R_a$     | 220  | 100  | 47   | 220  | 100  | 47   | k $\Omega$ |
| Grid resistor next stage | $R_g'$    | 0.68 | 0.33 | 0.15 | 0.68 | 0.33 | 0.15 | M $\Omega$ |
| Anode current            | $I_a$     | 0.46 | 0.82 | 1.25 | 0.21 | 0.35 | 0.52 | mA         |
| Voltage gain             | $V_o/V_i$ | 51   | 42   | 32   | 44   | 35   | 26   | -          |

Distortion:

|  |                  |     |     |     |     |     |     |   |
|--|------------------|-----|-----|-----|-----|-----|-----|---|
| at output voltage $V_o = 3 \text{ V}_{\text{RMS}}$ | $d_{\text{tot}}$ | 0.4 | 0.5 | 0.6 | 1.0 | 1.3 | 2.0 | % |
| at output voltage $V_o = 5 \text{ V}_{\text{RMS}}$ | $d_{\text{tot}}$ | 0.5 | 0.8 | 1.1 | 1.7 | 2.3 | 4.3 | % |
| at output voltage $V_o = 8 \text{ V}_{\text{RMS}}$ | $d_{\text{tot}}$ | 1.1 | 1.3 | 2.0 | -   | -   | -   | % |

**TYPICAL CHARACTERISTICS** Diode sections

|  |                   |                       |
|--|-------------------|-----------------------|
| Internal resistance diode No.1<br>Diode voltage $V_{d1} = +10$ V | $R_{iD1}$         | 5 k $\Omega$          |
| Internal resistance diode No.2<br>Diode voltage $V_{d2} = +5$ V  | $R_{iD2}$         | 200 $\Omega$          |
| Internal resistance diode No.3<br>Diode voltage $V_{d3} = +5$ V  | $R_{iD3}$         | 200 $\Omega$          |
| Ratio between $R_{iD2}$ and $R_{iD3}$                            | $R_{iD2}/R_{iD3}$ | min. 0.67<br>max. 1.5 |

**MICROPHONY** Triode section

No special precautions against microphony are required in circuits where the input voltage is min. 10 mV for 50 mW output of the output tube at frequencies higher than 800 Hz. At lower frequencies the sensitivity may be increased according to figure 1.

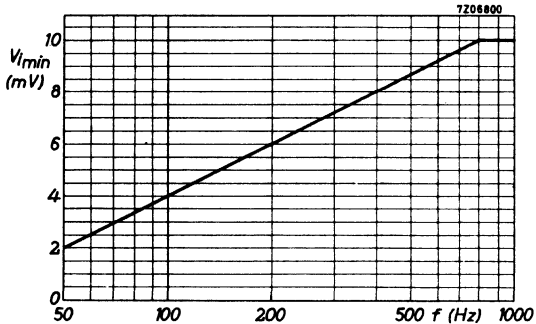

fig. 1

**LIMITING VALUES** (Design centre rating system)Triode section

|                                      |          |                   |
|--------------------------------------|----------|-------------------|
| Anode voltage                        | $V_{a0}$ | max. 550 V        |
|                                      | $V_a$    | max. 300 V        |
| Anode dissipation                    | $W_a$    | max. 1 W          |
| Cathode current                      | $I_k$    | max. 5 mA         |
| Grid resistor                        | $R_g$    | max. 3 $M\Omega$  |
| Grid resistor<br>(grid current bias) | $R_g$    | max. 22 $M\Omega$ |
| Cathode to heater voltage            | $V_{kf}$ | max. 150 V        |

Diode sections

|   |             |            |
|---|-------------|------------|
| Diode No.1 voltage, peak negative           | $-V_{d1p}$  | max. 350 V |
| Diode No.2 voltage, peak negative           | $-V_{d2p}$  | max. 350 V |
| Diode No.3 voltage, peak negative           | $-V_{d3p}$  | max. 350 V |
| Diode No.1 current:                         |             |            |
| D.C. component                              | $I_{d1}$    | max. 1 mA  |
| peak  | $I_{d1p}$   | max. 6 mA  |
| Diode No.2 current:                         |             |            |
| D.C. component                              | $I_{d2}$    | max. 10 mA |
| peak  | $I_{d2p}$   | max. 75 mA |
| Diode No.3 current:                         |             |            |
| D.C. component                              | $I_{d3}$    | max. 10 mA |
| peak  | $I_{d3p}$   | max. 75 mA |
| Cathode (D <sub>2</sub> ) to heater voltage | $V_{kD2/f}$ | max. 150 V |



**DOUBLE DIODE**

Double diode with separate cathodes.

**HEATING:** Indirect by A.C. or D.C.; series or parallel supply

Heater voltage

$V_f$  6.3 V

Heater current

$I_f$  300 mA

**DIMENSIONS AND CONNECTIONS**

Dimensions in mm

Base: Miniature

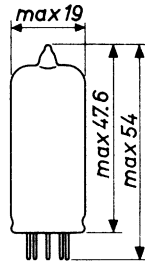
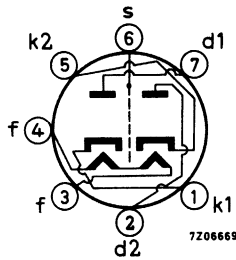

-----  
 For further data  
 please refer to type EAA91  
 -----





## DOUBLE DIODE-TRIODE

Double diode-triode. Triode intended for use as A. F. amplifier.

| QUICK REFERENCE DATA  |       |     |      |
|-----------------------|-------|-----|------|
| <u>Triode section</u> |       |     |      |
| Anode current         | $I_a$ | 1.0 | mA   |
| Transconductance      | $S$   | 1.2 | mA/V |
| Amplification factor  | $\mu$ | 70  | -    |

**HEATING:** Indirect by A. C. or D. C.; parallel supply

|                |       |     |    |
|----------------|-------|-----|----|
| Heater voltage | $V_f$ | 6.3 | V  |
| Heater current | $I_f$ | 230 | mA |

### DIMENSIONS AND CONNECTIONS

Dimensions in mm

Base: Noval

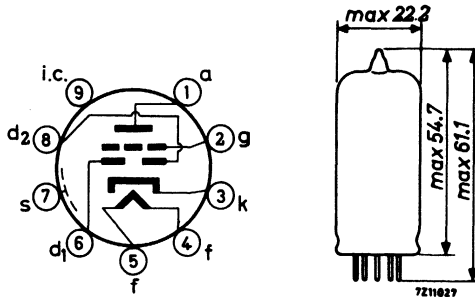

**CAPACITANCES**Triode section

|                          |            |              |
|--------------------------|------------|--------------|
| Grid to all except anode | $C_{g(a)}$ | 2.3 pF       |
| Anode to all except grid | $C_{a(g)}$ | 2.3 pF       |
| Anode to grid            | $C_{ag}$   | 1.2 pF       |
| Grid to heater           | $C_{gf}$   | max. 0.05 pF |

Diode sections

|                            |              |              |
|----------------------------|--------------|--------------|
| Diode No. 1 to all         | $C_{d_1}$    | 0.9 pF       |
| Diode No. 2 to all         | $C_{d_2}$    | 0.9 pF       |
| Diode No. 1 to diode No. 2 | $C_{d_1d_2}$ | max. 0.2 pF  |
| Diode No. 1 to heater      | $C_{d_1f}$   | max. 0.25 pF |
| Diode No. 2 to heater      | $C_{d_2f}$   | max. 0.05 pF |

Between diode and triode sections

|                      |            |              |
|----------------------|------------|--------------|
| Diode No. 1 to grid  | $C_{d_1g}$ | max.0.007 pF |
| Diode No. 2 to grid  | $C_{d_2g}$ | max.0.007 pF |
| Diode No. 1 to anode | $C_{d_1a}$ | max.0.005 pF |
| Diode No. 2 to anode | $C_{d_2a}$ | max.0.010 pF |

**TYPICAL CHARACTERISTICS**Triode section

|                                    |          |                    |
|------------------------------------|----------|--------------------|
| Anode voltage                      | $V_a$    | 250 V              |
| Grid voltage                       | $V_g$    | -3 V               |
| Anode current                      | $I_a$    | 1.0 mA             |
| Transconductance                   | $S$      | 1.2 mA/V           |
| Amplification factor               | $\mu$    | 70 -               |
| Internal resistance                | $R_i$    | 58 k $\Omega$      |
| Equivalent noise resistance (A.F.) | $R_{eq}$ | max.150 k $\Omega$ |

**OPERATING CHARACTERISTICS**

Triode section as A.F. amplifier, circuit Fig.1

|                                   |           |      |      |      |      |           |
|-----------------------------------|-----------|------|------|------|------|-----------|
| Supply voltage                    | $V_b$     | 250  | 250  | 250  | 250  | V         |
| Anode resistor                    | $R_a$     | 0.22 | 0.1  | 0.22 | 0.1  | $M\Omega$ |
| Cathode resistor                  | $R_k$     | 1.8  | 1.2  | 0    | 0    | $k\Omega$ |
| Grid resistor                     | $R_g$     | 1    | 1    | 22   | 22   | $M\Omega$ |
| Grid resistor next stage          | $R_{g'}$  | 0.68 | 0.33 | 0.68 | 0.33 | $M\Omega$ |
| Anode current                     | $I_a$     | 0.70 | 1.15 | 0.76 | 1.40 | mA        |
| Voltage gain                      | $V_o/V_i$ | 51   | 43   | 52   | 44   | -         |
| Distortion:                       |           |      |      |      |      |           |
| at output voltage $V_o = 5$ VRMS  | $d_{tot}$ | 0.55 | 0.6  | 0.5  | 0.7  | %         |
| at output voltage $V_o = 10$ VRMS | $d_{tot}$ | 0.9  | 1.1  | 0.8  | 0.9  | %         |

Microphony

No special precautions against microphony are required in circuits where the input voltage is min. 10 mV for 50 mW output of the output tube.

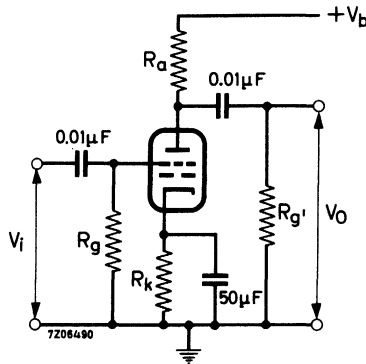

fig.1

**LIMITING VALUES** (Design centre rating system)Triode section

|                           |          |                   |
|---------------------------|----------|-------------------|
| Anode voltage             | $V_{a0}$ | max. 550 V        |
|                           | $V_a$    | max. 300 V        |
| Anode dissipation         | $W_a$    | max. 0.5 W        |
| Cathode current           | $I_k$    | max. 5 mA         |
| Grid resistor             | $R_g$    | max. 3 M $\Omega$ |
| Cathode to heater voltage | $V_{kf}$ | max. 100 V        |

Diode sections (each diode)

|                              |           |             |
|------------------------------|-----------|-------------|
| Diode voltage, negative peak | $-V_{dp}$ | max. 350 V  |
| Diode current, average       | $I_d$     | max. 0.8 mA |
| peak                         | $I_{dp}$  | max. 5 mA   |
| Cathode to heater voltage    | $V_{kf}$  | max. 100 V  |

Note

The use of a socket with skirt is advisable to reduce the capacitances between tube elements and external conductors.

## DOUBLE DIODE-PENTODE

Double diode-pentode. Pentode intended for use as R.F., I.F., or A.F. amplifier.

| QUICK REFERENCE DATA      |                |     |      |
|---------------------------|----------------|-----|------|
| <u>Pentode section</u>    |                |     |      |
| Variable transconductance |                |     |      |
| Anode current             | $I_a$          | 5   | mA   |
| Transconductance          | $S$            | 2.2 | mA/V |
| Amplification             | $\mu_{g_2g_1}$ | 18  | -    |

**HEATING:** Indirect by A.C. or D.C.; parallel or series supply.

|                |       |     |    |
|----------------|-------|-----|----|
| Heater voltage | $V_f$ | 6.3 | V  |
| Heater current | $I_f$ | 300 | mA |

### DIMENSIONS AND CONNECTIONS

Dimensions in mm

Base: Noval

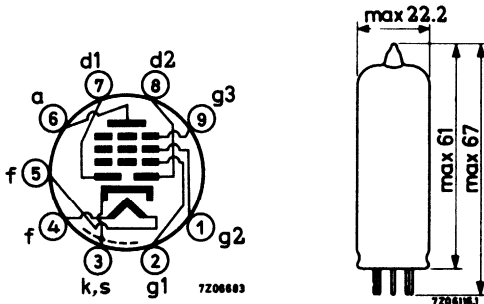

**CAPACITANCES**

Pentode section

|                               |              |                |
|-------------------------------|--------------|----------------|
| Anode to all except grid No.1 | $C_{a(g_1)}$ | 4.9 pF         |
| Grid No.1 to all except anode | $C_{g_1(a)}$ | 4.2 pF         |
| Anode to grid No.1            | $C_{ag_1}$   | max. 0.0025 pF |
| Grid No.1 to heater           | $C_{g_1f}$   | max. 0.07 pF   |

Diode section

|                          |              |               |
|--------------------------|--------------|---------------|
| Diode No.1 to all        | $C_{d_1}$    | 2.2 pF        |
| Diode No.2 to all        | $C_{d_2}$    | 2.35 pF       |
| Diode No.1 to diode No.2 | $C_{d_1d_2}$ | max. 0.35 pF  |
| Diode No.1 to heater     | $C_{d_1f}$   | max. 0.02 pF  |
| Diode No.2 to heater     | $C_{d_2f}$   | max. 0.005 pF |

Between diode and pentode sections

|                         |              |                |
|-------------------------|--------------|----------------|
| Diode No.1 to grid No.1 | $C_{d_1g_1}$ | max. 0.0008 pF |
| Diode No.2 to grid No.1 | $C_{d_2d_1}$ | max. 0.001 pF  |
| Diode No.1 to anode     | $C_{d_1a}$   | max. 0.2 pF    |
| Diode No.2 to anode     | $C_{d_2a}$   | max. 0.05 pF   |

**OPERATING CHARACTERISTICS**

Pentode section as R.F. or I.F. amplifier

|                             |                |      |                  |
|-----------------------------|----------------|------|------------------|
| Supply voltage              | $V_b$          | 250  | V                |
| Anode resistor              | $R_a$          | 0    | $\Omega$         |
| Grid No.3 voltage           | $V_{g_3}$      | 0    | V                |
| Grid No.2 resistor          | $R_{g_2}$      | 95   | $k\Omega$        |
| Cathode resistor            | $R_k$          | 300  | $\Omega$         |
| Grid No.1 voltage           | $V_g$          | -2   | -41.5 V          |
| Grid No.2 voltage           | $V_{g_2}$      | 85   | 250 V            |
| Anode current               | $I_a$          | 5    | - mA             |
| Grid No.2 current           | $I_{g_2}$      | 1.75 | - mA             |
| Transconductance            | S              | 2200 | 22 $\mu A/V$     |
| Internal resistance         | $R_i$          | 1.4  | min.10 $M\Omega$ |
| Amplification factor        | $\mu_{g_2g_1}$ | 18   | - -              |
| Equivalent noise resistance | $R_{eq}$       | 6.8  | - $k\Omega$      |

Pentode section as resistance coupled A.F. amplifier, circuit fig.1.

|                               |            |      |      |      |      |           |
|-------------------------------|------------|------|------|------|------|-----------|
| Supply voltage                | $V_b$      | 250  | 250  | 250  | 250  | V         |
| Anode resistor                | $R_a$      | 0.22 | 0.1  | 0.22 | 0.1  | $M\Omega$ |
| Grid No.2 resistor            | $R_{g_2}$  | 0.82 | 0.39 | 1.0  | 0.47 | $M\Omega$ |
| Grid No.1 resistor            | $R_{g_1}$  | 1    | 1    | 10   | 10   | $M\Omega$ |
| Cathode resistor              | $R_k$      | 1800 | 1000 | 0    | 0    | $\Omega$  |
| Grid No.1 resistor next stage | $R_{g_1}'$ | 0.68 | 0.33 | 0.68 | 0.33 | $M\Omega$ |
| Anode current                 | $I_a$      | 0.75 | 1.5  | 0.75 | 1.5  | mA        |
| Grid No.2 current             | $I_{g_2}$  | 0.30 | 0.53 | 0.25 | 0.50 | mA        |
| Voltage gain                  | $V_o/V_i$  | 110  | 80   | 160  | 110  | -         |

**Distortion:**

|                                     |           |     |     |     |     |   |
|-------------------------------------|-----------|-----|-----|-----|-----|---|
| at output voltage $V_o = 3 V_{RMS}$ | $d_{tot}$ | 0.8 | 0.9 | 0.8 | 0.8 | % |
| at output voltage $V_o = 5 V_{RMS}$ | $d_{tot}$ | 1.3 | 1.5 | 1.4 | 1.4 | % |
| at output voltage $V_o = 8 V_{RMS}$ | $d_{tot}$ | 2.0 | 2.2 | 2.1 | 2.1 | % |

**OPERATING CHARACTERISTICS (continued)**

Pentode section, triode connected ( $g_2$  connected to anode) as resistance coupled A.F. amplifier.

|                                     |           |      |       |      |       |            |
|-------------------------------------|-----------|------|-------|------|-------|------------|
| Supply voltage                      | $V_b$     | 250  | 250   | 250  | 250   | V          |
| Anode resistor                      | $R_a$     | 0.1  | 0.047 | 0.1  | 0.047 | M $\Omega$ |
| Grid No.1 resistor                  | $R_{g_1}$ | 1    | 1     | 10   | 10    | M $\Omega$ |
| Cathode resistor                    | $R_k$     | 820  | 560   | 0    | 0     | $\Omega$   |
| Grid No.1 resistor next stage       | $R_{g'}$  | 0.33 | 0.15  | 0.33 | 0.15  | M $\Omega$ |
| Anode current                       | $I_a$     | 2.08 | 4.10  | 2.16 | 4.50  | mA         |
| Voltage gain                        | $V_o/V_i$ | 14   | 13    | 15   | 15    | -          |
| Distortion:                         |           |      |       |      |       |            |
| at output voltage $V_o = 3 V_{RMS}$ | $d_{tot}$ | 1.6  | 1.3   | 2.0  | 1.7   | %          |
| at output voltage $V_o = 5 V_{RMS}$ | $d_{tot}$ | 2.5  | 2.0   | 3.1  | 2.7   | %          |
| at output voltage $V_o = 8 V_{RMS}$ | $d_{tot}$ | 4.3  | 2.9   | 4.8  | 4.1   | %          |

**LIMITING VALUES (Design centre rating system)**

Pentode section

|  |               |      |     |            |
|--|---------------|------|-----|------------|
| Anode voltage  | $V_{a_0}$     | max. | 550 | V          |
|  | $V_a$         | max. | 300 | V          |
| Anode dissipation                                    | $W_a$         | max. | 1.5 | W          |
| Grid No.2 voltage                                    | $V_{g_{2_0}}$ | max. | 550 | V          |
| at anode current $I_a = \text{max. } 2.5 \text{ mA}$ | $V_{g_2}$     | max. | 300 | V          |
| at anode current $I_a = 5 \text{ mA}$                | $V_{g_2}$     | max. | 125 | V          |
| Grid No.2 dissipation                                | $W_{g_2}$     | max. | 0.3 | W          |
| Cathode current                                      | $I_k$         | max. | 10  | mA         |
| Grid resistor, automatic bias                        | $R_{g_1}$     | max. | 3   | M $\Omega$ |
| Grid resistor, grid current bias                     | $R_{g_1}$     | max. | 22  | M $\Omega$ |
| Cathode to heater voltage                            | $V_{kf}$      | max. | 100 | V          |

Microphony

No special precautions against microphony are required in circuits where the input voltage is min. 25 mV for an output of 50 mW of the output tube.



**LIMITING VALUES** (continued)

Diode section

|                                   |              |             |
|-----------------------------------|--------------|-------------|
| Diode No.1 voltage, negative peak | $-V_{d_p}$   | max. 350 V  |
| Diode No.2 voltage, negative peak | $-V_{d_p}$   | max. 350 V  |
| Diode No.1 current                | $I_{d_1}$    | max. 0.8 mA |
| Diode No.2 current                | $I_{d_2}$    | max. 0.8 mA |
| Diode No.1 current, peak          | $I_{d_{1p}}$ | max. 5 mA   |
| Diode No.2 current, peak          | $I_{d_{2p}}$ | max. 5 mA   |
| Cathode to heater voltage         | $V_{kf}$     | max. 100 V  |

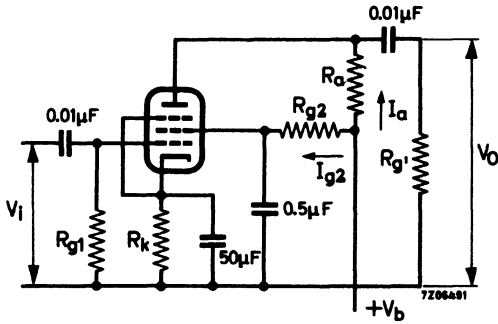

fig. 1



**DOUBLE DIODE – PENTODE**

Double diode-pentode. Pentode intended for use as R. F. or I. F. amplifier.

| QUICK REFERENCE DATA      |                |     |      |
|---------------------------|----------------|-----|------|
| <u>Pentode section</u>    |                |     |      |
| Variable transconductance |                |     |      |
| Anode current             | $I_a$          | 9   | mA   |
| Transconductance          | S              | 4.5 | mA/V |
| Amplification factor      | $\mu_{g_2g_1}$ | 20  | --   |

**HEATING:** Indirect by A. C. or D. C.; parallel or series supply

|                |       |     |    |
|----------------|-------|-----|----|
| Heater voltage | $V_f$ | 6.3 | V  |
| Heater current | $I_f$ | 300 | mA |

**DIMENSIONS AND CONNECTIONS**

Dimensions in mm

Base: Noval

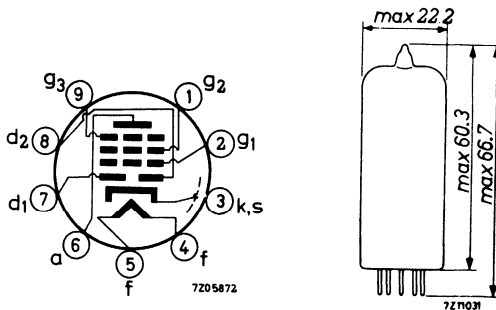

**CAPACITANCES**Pentode section

|                                |              |                |
|--------------------------------|--------------|----------------|
| Anode to all except grid No. 1 | $C_{a(g_1)}$ | 5.2 pF         |
| Grid No. 1 to all except anode | $C_{g_1(a)}$ | 5.0 pF         |
| Anode to grid No. 1            | $C_{ag_1}$   | max. 0.0025 pF |
| Grid No. 1 to heater           | $C_{g_1f}$   | max. 0.05 pF   |

Diode sections

|                            |              |               |
|----------------------------|--------------|---------------|
| Diode No. 1 to all         | $C_{d_1}$    | 2.5 pF        |
| Diode No. 2 to all         | $C_{d_2}$    | 2.5 pF        |
| Diode No. 1 to diode No. 2 | $C_{d_1d_2}$ | max. 0.25 pF  |
| Diode No. 1 to heater      | $C_{d_1f}$   | max. 0.015 pF |
| Diode No. 2 to heater      | $C_{d_2f}$   | max. 0.003 pF |

Between diode and pentode sections

|                           |              |                |
|---------------------------|--------------|----------------|
| Diode No. 1 to grid No. 1 | $C_{d_1g_1}$ | max. 0.0008 pF |
| Diode No. 2 to grid No. 1 | $C_{d_2g_1}$ | max. 0.001 pF  |
| Diode No. 1 to anode      | $C_{d_1a}$   | max. 0.15 pF   |
| Diode No. 2 to anode      | $C_{d_2a}$   | max. 0.025 pF  |

**TYPICAL CHARACTERISTICS**

Pentode section

|                      |                |     |       |      |       |      |
|----------------------|----------------|-----|-------|------|-------|------|
| Anode voltage        | $V_a$          | 250 | 250   | 200  | 170   | V    |
| Grid No. 2 voltage   | $V_{g_2}$      | 100 | 80    | 100  | 100   | V    |
| Grid No. 3 voltage   | $V_{g_3}$      | 0   | 0     | 0    | 0     | V    |
| Grid No. 1 voltage   | $V_{g_1}$      | -2  | -1 1) | -1.5 | -1 1) | V    |
| Anode current        | $I_a$          | 9   | 9     | 11   | 12    | mA   |
| Grid No. 2 current   | $I_{g_2}$      | 2.7 | 2.7   | 3.3  | 4     | mA   |
| Transconductance     | S              | 3.8 | 4.5   | 4.5  | 5     | mA/V |
| Amplification factor | $\mu_{g_2g_1}$ | 20  | 20    | 20   | 20    | -    |
| Internal resistance  | $R_i$          | 1.0 | 0.9   | 0.6  | 0.4   | MΩ   |

**OPERATING CHARACTERISTICS**

Pentode section as R. F. or I. F. amplifier

|                     |           |      |     |      |      |       |          |
|---------------------|-----------|------|-----|------|------|-------|----------|
| Supply voltage      | $V_b$     | 250  |     | 200  |      | 250   | V        |
| Anode resistor      | $R_a$     | 0    |     | 0    |      | 0     | Ω        |
| Grid No. 3 voltage  | $V_{g_3}$ | 0    |     | 0    |      | 0     | V        |
| Grid No. 2 resistor | $R_{g_2}$ | 56   |     | 30   |      | 62    | kΩ       |
| Grid No. 1 voltage  | $V_{g_1}$ | -2.0 | -20 | -1.5 | -20  | -1 1) | -20 V    |
| Anode current       | $I_a$     | 9    | -   | 11   | -    | 9     | - mA     |
| Grid No. 2 current  | $I_{g_2}$ | 2.7  | -   | 3.3  | -    | 2.7   | - mA     |
| Transconductance    | S         | 3.8  | 0.2 | 4.5  | 0.12 | 4.5   | 0.2 mA/V |
| Internal resistance | $R_i$     | 1.0  | -   | 0.6  | -    | 0.9   | - MΩ     |

1) To avoid grid No. 1 current the negative grid No. 1 voltage should be min. 1.5 V.

**LIMITING VALUES** (Design centre rating system)

Pentode section

|                                  |           |                          |
|----------------------------------|-----------|--------------------------|
| Anode voltage                    | $V_{a0}$  | max. 550 V               |
|                                  | $V_a$     | max. 300 V <sup>1)</sup> |
| Anode dissipation                | $W_a$     | max. 2.25 W              |
| Grid No.2 voltage                | $V_{g20}$ | max. 550 V               |
| Grid No.2 voltage                |           |                          |
| at anode current $I_a$ max. 4 mA | $V_{g2}$  | max. 300 V <sup>1)</sup> |
| at anode current $I_a$ min. 8 mA | $V_{g2}$  | max. 125 V               |
| Grid No.2 dissipation            | $W_{g2}$  | max. 0.45 W              |
| Cathode current                  | $I_k$     | max. 16.5 mA             |
| Grid No.1 resistor               | $R_{g1}$  | max. 3 M $\Omega$        |
| Grid No.3 resistor               | $R_{g3}$  | max. 10 k $\Omega$       |
| Cathode to heater voltage        | $V_{kf}$  | max. 100 V               |

Diode sections (each diode)

|                              |           |             |
|------------------------------|-----------|-------------|
| Diode voltage, negative peak | $-V_{dp}$ | max. 200 V  |
| Diode current, average       | $I_d$     | max. 0.8 mA |
| peak                         | $I_{dp}$  | max. 5 mA   |
| Cathode to heater voltage    | $V_{kf}$  | max. 100 V  |

<sup>1)</sup> With supply from a storage battery and vibrator the max. voltage is 250 V.

## U.H.F. TRIODE

Triode intended for use as grounded grid U.H.F. amplifier, oscillator or mixer for bands IV and V.

**HEATING:** Indirect by A.C. or D.C.; parallel supply

|                |       |        |
|----------------|-------|--------|
| Heater voltage | $V_f$ | 6.3 V  |
| Heater current | $I_f$ | 200 mA |

**LIMITING VALUES** (Design centre rating system)

|                                    |                  |            |
|------------------------------------|------------------|------------|
| Cathode to heater voltage, (k pos) | $V_{kf}$ (k pos) | max. 100 V |
| (k neg)                            | $V_{kf}$ (k neg) | max. 50 V  |

-----  
For further data and curves of this type  
please refer to PC86  
-----





**U.H.F. TRIODE**

Triode intended for use as grounded grid U.H.F. amplifier for bands IV and V.

**HEATING:** Indirect by A.C. or D.C.; parallel supply

Heater voltage

$V_f$  6.3 V

Heater current

$I_f$  165 mA

-----  
For further data and curves of this type  
please refer to PC88  
-----



### R.F. TRIODE

Triode intended for use as oscillator, mixer or amplifier in F.M. - and television receivers.

| QUICK REFERENCE DATA |       |     |      |
|----------------------|-------|-----|------|
| Anode current        | $I_a$ | 10  | mA   |
| Transconductance     | S     | 5.5 | mA/V |
| Amplification factor | $\mu$ | 60  |      |

**HEATING:** Indirect by A.C. or D.C.; series or parallel supply

|                |       |     |    |
|----------------|-------|-----|----|
| Heater voltage | $V_f$ | 6.3 | V  |
| Heater current | $I_f$ | 150 | mA |

#### DIMENSIONS AND CONNECTIONS

Dimensions in mm

Base: Miniature

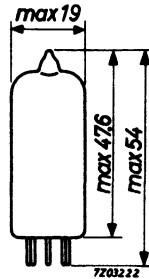
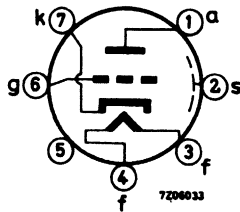

#### CAPACITANCES

|                          |            |           |    |
|--------------------------|------------|-----------|----|
| Grid to all except anode | $C_{g(a)}$ | 2.6       | pF |
| Anode to all except grid | $C_{a(g)}$ | 0.55      | pF |
| Anode to grid            | $C_{ag}$   | 1.6       | pF |
| Anode to cathode         | $C_{ak}$   | 0.24      | pF |
| Cathode to heater        | $C_{kf}$   | 2.2       | pF |
| Grid to heater           | $C_{gf}$   | max. 0.15 | pF |
| Anode to grid + heater   | $C_{a/gf}$ | 1.8       | pF |
| Cathode to grid + heater | $C_{k/gf}$ | 4.5       | pF |

**TYPICAL CHARACTERISTICS AND OPERATING CONDITIONS**

|                      |       |      |      |      |      |            |
|----------------------|-------|------|------|------|------|------------|
| Anode voltage        | $V_a$ | 100  | 170  | 200  | 250  | V          |
| Grid voltage         | $V_g$ | -1.0 | -1.0 | -1.0 | -2.0 | V          |
| Anode current        | $I_a$ | 3.0  | 8.5  | 11.5 | 10   | mA         |
| Transconductance     | S     | 3.75 | 5.9  | 6.7  | 5.5  | mA/V       |
| Amplification factor | $\mu$ | 62   | 66   | 70   | 60   |            |
| Internal resistance  | $R_i$ | 16.5 | 11   | 10.5 | 11   | k $\Omega$ |

**LIMITING VALUES** (Design centre rating system)

|                                |          |      |     |            |
|--------------------------------|----------|------|-----|------------|
| Anode voltage                  | $V_{a0}$ | max. | 550 | V          |
|                                | $V_a$    | max. | 300 | V          |
| Anode dissipation              | $W_a$    | max. | 2.5 | W          |
| Cathode current                | $I_k$    | max. | 15  | mA         |
| Grid voltage                   | $-V_g$   | max. | 50  | V          |
| Grid resistor (automatic bias) | $R_g$    | max. | 1   | M $\Omega$ |
| Cathode to heater voltage      | $V_{kf}$ | max. | 100 | V          |

-----  
 For curves please refer to type ECC81  
 -----

**V.H.F. TRIODE**

Triode intended for use as R.F. amplifier in V.H.F. television tuners.

**HEATING:** Indirect by A.C. or D.C.; parallel supply

|                |       |        |
|----------------|-------|--------|
| Heater voltage | $V_f$ | 6.3 V  |
| Heater current | $I_f$ | 180 mA |

-----  
For further data and curves of this type  
please refer to type PC900  
-----



## R.F. DOUBLE TRIODE

Double triode intended for use as oscillator, mixer or amplifier in television receivers.

| QUICK REFERENCE DATA<br>(each unit) |       |     |      |
|-------------------------------------|-------|-----|------|
| Anode current                       | $I_a$ | 10  | mA   |
| Transconductance                    | S     | 5.5 | mA/V |
| Amplification factor                | $\mu$ | 60  | -    |

**HEATING:** Indirect by A.C. or D.C.; series or parallel supply

|                |       |                   |                   |    |
|----------------|-------|-------------------|-------------------|----|
| Heater voltage | $V_f$ | 6.3               | 12.6              | V  |
| Heater current | $I_f$ | 300 <sup>1)</sup> | 150 <sup>1)</sup> | mA |
|                |       | pins 9-(4+5)      | pins 4-5          |    |

### DIMENSIONS AND CONNECTIONS

Dimensions in mm

Base: Noval

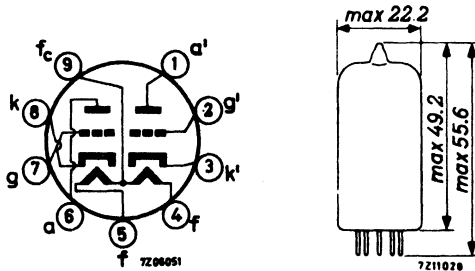

<sup>1)</sup> In case of series supply a current limiting device must be inserted in the heater circuit for limiting the current when switching on.

**CAPACITANCES**

|                          |               |      |       |    |
|--------------------------|---------------|------|-------|----|
| Grid to all except anode | $C_{g(a)}$    |      | 2.3   | pF |
|                          | $C_{g'(a')}$  |      | 2.3   | pF |
| Anode to all except grid | $C_{a(g)}$    |      | 0.45  | pF |
|                          | $C_{a'(g')}$  |      | 0.35  | pF |
| Anode to grid            | $C_{ag}$      |      | 1.6   | pF |
|                          | $C_{a'g'}$    |      | 1.6   | pF |
| Anode to cathode         | $C_{ak}$      |      | 0.20  | pF |
|                          | $C_{a'k'}$    |      | 0.20  | pF |
| Cathode to heater        | $C_{kf}$      |      | 2.5   | pF |
|                          | $C_{k'f}$     |      | 2.5   | pF |
| Cathode to grid + heater | $C_{k/g+f}$   |      | 4.7   | pF |
|                          | $C_{k'/g'+f}$ |      | 4.7   | pF |
| Anode to grid + heater   | $C_{a/g+f}$   |      | 1.9   | pF |
|                          | $C_{a'/g'+f}$ |      | 1.8   | pF |
| Grid to heater           | $C_{gf}$      | max. | 0.17  | pF |
|                          | $C_{g'f}$     | max. | 0.17  | pF |
| Anode to anode           | $C_{aa'}$     | max. | 0.4   | pF |
| Grid to grid             | $C_{gg'}$     | max. | 0.005 | pF |
| Anode to grid other unit | $C_{ag'}$     | max. | 0.07  | pF |
| Grid to anode other unit | $C_{ga'}$     | max. | 0.04  | pF |

**TYPICAL CHARACTERISTICS AND OPERATING CONDITIONS** (each unit)

|                      |       |      |      |      |      |            |
|----------------------|-------|------|------|------|------|------------|
| Anode voltage        | $V_a$ | 100  | 170  | 200  | 250  | V          |
| Grid voltage         | $V_g$ | -1.0 | -1.0 | -1.0 | -2.0 | V          |
| Anode current        | $I_a$ | 3.0  | 8.5  | 11.5 | 10   | mA         |
| Transconductance     | $S$   | 3.75 | 5.9  | 6.7  | 5.5  | mA/V       |
| Amplification factor | $\mu$ | 62   | 66   | 70   | 60   |            |
| Internal resistance  | $R_i$ | 16.5 | 11   | 10.5 | 11   | k $\Omega$ |

**LIMITING VALUES** (Design centre rating system) (each unit)

|                                |          |      |     |            |
|--------------------------------|----------|------|-----|------------|
| Anode voltage                  | $V_{a0}$ | max. | 550 | V          |
|                                | $V_a$    | max. | 300 | V          |
| Anode dissipation              | $W_a$    | max. | 2.5 | W          |
| Cathode current                | $I_k$    | max. | 15  | mA         |
| Grid voltage                   | $-V_g$   | max. | 50  | V          |
| Grid resistor (automatic bias) | $R_g$    | max. | 1   | M $\Omega$ |
| Cathode to heater voltage      | $V_{kf}$ | max. | 90  | V          |



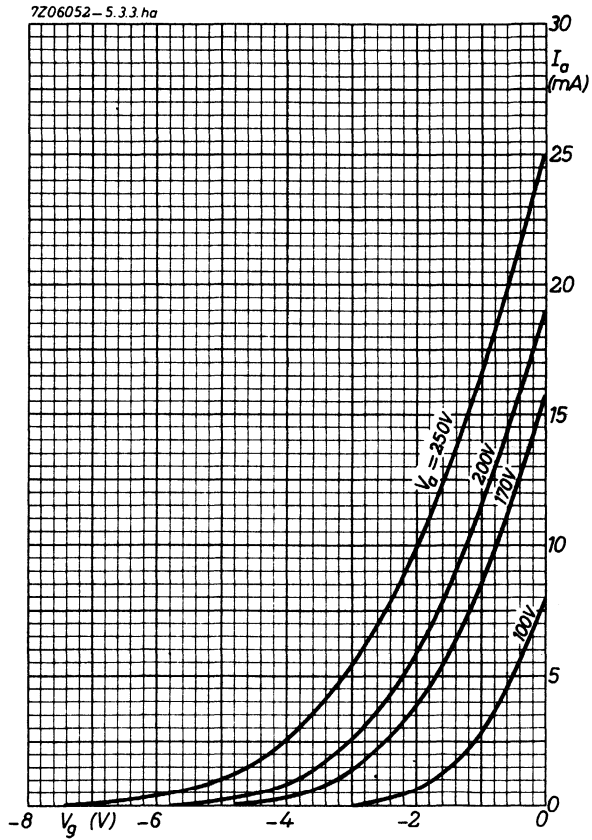

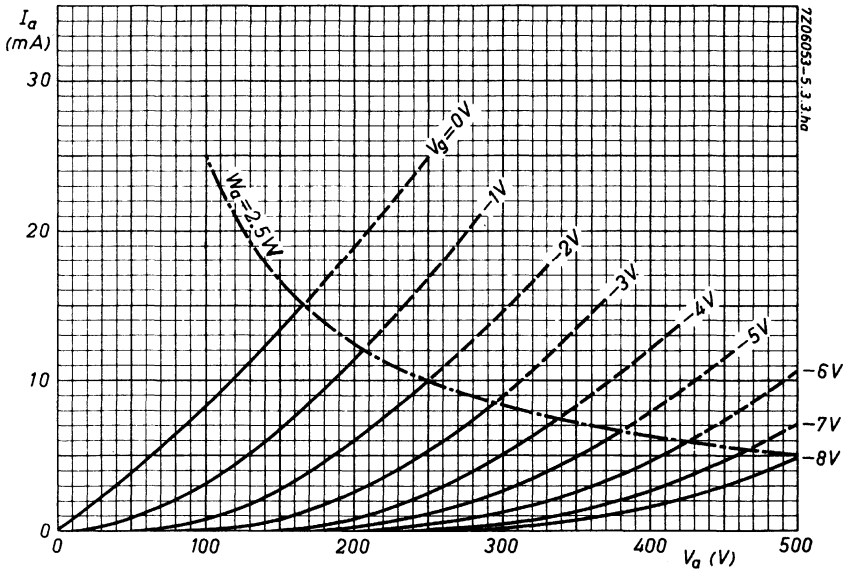

## A.F. DOUBLE TRIODE

Double triode intended for use as A.F. amplifier.

| QUICK REFERENCE DATA<br>(each unit) |       |      |      |
|-------------------------------------|-------|------|------|
| Anode current                       | $I_a$ | 10.5 | mA   |
| Transconductance                    | $S$   | 2.2  | mA/V |
| Amplification factor                | $\mu$ | 17   | -    |

**HEATING:** Indirect by A.C. or D.C.; series or parallel supply

|                |       |              |      |          |
|----------------|-------|--------------|------|----------|
| Heater voltage | $V_f$ | 6.3          | 12.6 | V        |
| Heater current | $I_f$ | 300          | 150  | mA       |
|                |       | pins 9-(4+5) |      | pins 4-5 |

### DIMENSIONS AND CONNECTIONS

Dimensions in mm

Base: Noval

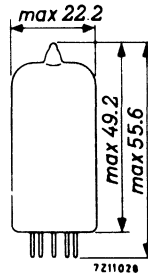
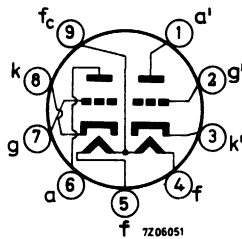

### REMARK

With  $V_f$  applied to pins 4+5 and 9 and the centre tap of the heater transformer connected to earth, the more favourable triode section of the tube with regard to hum is the section connected to pins 6, 7 and 8.

**CAPACITANCES**

|                          |              |            |    |
|--------------------------|--------------|------------|----|
| Grid to all except anode | $C_{g(a)}$   | 1.8        | pF |
|                          | $C_{g'(a')}$ | 1.8        | pF |
| Anode to all except grid | $C_{a(g)}$   | 0.37       | pF |
|                          | $C_{a'(g')}$ | 0.25       | pF |
| Anode to grid            | $C_{ag}$     | 1.5        | pF |
|                          | $C_{a'g'}$   | 1.5        | pF |
| Grid to heater           | $C_{gf}$     | max. 0.135 | pF |
|                          | $C_{g'f}$    | max. 0.135 | pF |
| Anode to anode           | $C_{aa'}$    | max. 1.1   | pF |
| Anode to grid other unit | $C_{ag'}$    | max. 0.11  | pF |
| Grid to anode other unit | $C_{ga'}$    | max. 0.06  | pF |
| Grid to grid             | $C_{gg'}$    | max. 0.010 | pF |

**TYPICAL CHARACTERISTICS**

|                      |       |      |      |            |
|----------------------|-------|------|------|------------|
| Anode voltage        | $V_a$ | 100  | 250  | V          |
| Grid voltage         | $V_g$ | 0    | -8.5 | V          |
| Anode current        | $I_a$ | 11.8 | 10.5 | mA         |
| Transconductance     | S     | 3.1  | 2.2  | mA/V       |
| Amplification factor | $\mu$ | 19.5 | 17   | -          |
| Internal resistance  | $R_i$ | 6.25 | 7.7  | k $\Omega$ |

**OPERATING CHARACTERISTICS**

As A.F. amplifier, one unit

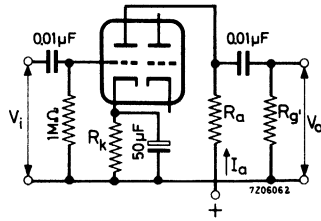

|   |           |      |      |      |      |      |      |      |           |
|---|-----------|------|------|------|------|------|------|------|-----------|
| Supply voltage                          | $V_b$     | 100  | 150  | 200  | 250  | 300  | 350  | 400  | V         |
| Anode resistor                          | $R_a$     | 47   | 47   | 47   | 47   | 47   | 47   | 47   | $k\Omega$ |
| Grid resistor<br>next stage             | $R_{g'}$  | 150  | 150  | 150  | 150  | 150  | 150  | 150  | $k\Omega$ |
| Cathode resistor                        | $R_k$     | 1.2  | 1.2  | 1.2  | 1.2  | 1.2  | 1.2  | 1.2  | $k\Omega$ |
| Anode current                           | $I_a$     | 1.20 | 1.82 | 2.41 | 3.02 | 3.65 | 4.30 | 5.00 | mA        |
| Voltage gain                            | $V_o/V_i$ | 13.5 | 13.5 | 13.5 | 13.5 | 13.5 | 13.5 | 13.5 | -         |
| Output voltage<br>( $I_g = 0.3 \mu A$ ) | $V_o$     | 11   | 18   | 26   | 34   | 43   | 51   | 59   | $V_{RMS}$ |
| Total distortion                        | $d_{tot}$ | 5.6  | 6.1  | 6.3  | 6.4  | 6.5  | 6.6  | 6.7  | %         |

|   |           |      |      |      |      |      |      |      |           |
|---|-----------|------|------|------|------|------|------|------|-----------|
| Supply voltage                          | $V_b$     | 100  | 150  | 200  | 250  | 300  | 350  | 400  | V         |
| Anode resistor                          | $R_a$     | 100  | 100  | 100  | 100  | 100  | 100  | 100  | $k\Omega$ |
| Grid resistor<br>next stage             | $R_{g'}$  | 330  | 330  | 330  | 330  | 330  | 330  | 330  | $k\Omega$ |
| Cathode resistor                        | $R_k$     | 2.2  | 2.2  | 2.2  | 2.2  | 2.2  | 2.2  | 2.2  | $k\Omega$ |
| Anode current                           | $I_a$     | 0.66 | 0.98 | 1.30 | 1.63 | 1.97 | 2.30 | 2.62 | mA        |
| Voltage gain                            | $V_o/V_i$ | 14   | 14   | 14   | 14   | 14   | 14   | 14   | -         |
| Output voltage<br>( $I_g = 0.3 \mu A$ ) | $V_o$     | 10   | 17   | 25   | 32   | 41   | 49   | 57   | $V_{RMS}$ |
| Total distortion                        | $d_{tot}$ | 4.8  | 5.6  | 5.8  | 5.9  | 6.0  | 6.1  | 6.2  | %         |

|   |           |      |      |      |      |      |      |      |           |
|---|-----------|------|------|------|------|------|------|------|-----------|
| Supply voltage                          | $V_b$     | 100  | 150  | 200  | 250  | 300  | 350  | 400  | V         |
| Anode resistor                          | $R_a$     | 220  | 220  | 220  | 220  | 220  | 220  | 220  | $k\Omega$ |
| Grid resistor<br>next stage             | $R_{g'}$  | 680  | 680  | 680  | 680  | 680  | 680  | 680  | $k\Omega$ |
| Cathode resistor                        | $R_k$     | 3.9  | 3.9  | 3.9  | 3.9  | 3.9  | 3.9  | 3.9  | $k\Omega$ |
| Anode current                           | $I_a$     | 0.33 | 0.50 | 0.66 | 0.82 | 0.98 | 1.16 | 1.31 | mA        |
| Voltage gain                            | $V_o/V_i$ | 14.5 | 14.5 | 14.5 | 14.5 | 14.5 | 14.5 | 14.5 | -         |
| Output voltage<br>( $I_g = 0.3 \mu A$ ) | $V_o$     | 8    | 15   | 22   | 28   | 36   | 43   | 50   | $V_{RMS}$ |
| Total distortion                        | $d_{tot}$ | 4.0  | 4.4  | 4.7  | 4.8  | 4.9  | 5.0  | 5.1  | %         |

## OPERATING CHARACTERISTICS (continued)

### Two sections in cascade

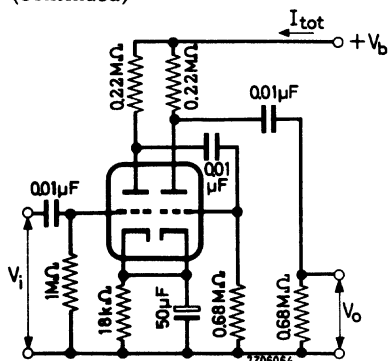

|                                      |           |      |      |           |
|--------------------------------------|-----------|------|------|-----------|
| Supply voltage                       | $V_b$     | 250  | 350  | V         |
| Total current                        | $I_{tot}$ | 1.66 | 2.33 | mA        |
| Voltage gain                         | $V_o/V_i$ | 178  | 178  | -         |
| Output voltage ( $I_g = 0.3 \mu A$ ) | $V_o$     | 15   | 25   | $V_{RMS}$ |
| Total distortion                     | $d_{tot}$ | 2    | 2    | %         |

### As phase inverter

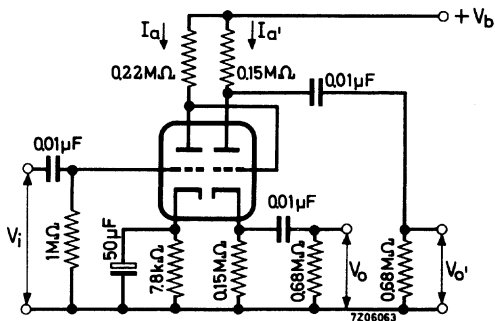

|                                      |           |      |      |           |
|--------------------------------------|-----------|------|------|-----------|
| Supply voltage                       | $V_b$     | 250  | 350  | V         |
| Anode current                        | $I_a$     | 0.70 | 1.00 | mA        |
| Anode current                        | $I_{a'}$  | 0.68 | 0.93 | mA        |
| Voltage gain                         | $V_o/V_i$ | 11   | 11   | -         |
| Output voltage ( $I_g = 0.3 \mu A$ ) | $V_o$     | 15   | 24   | $V_{RMS}$ |
| Total distortion                     | $d_{tot}$ | 1    | 1    | %         |

OPERATING CHARACTERISTICS (continued)

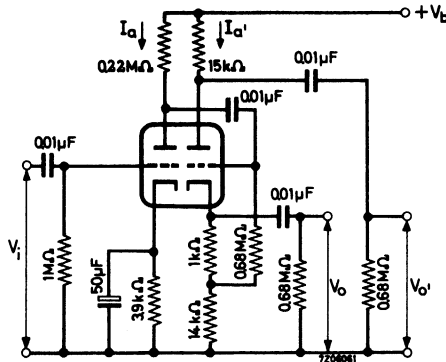

|                                      |           |      |      |           |
|--------------------------------------|-----------|------|------|-----------|
| Supply voltage                       | $V_b$     | 250  | 350  | V         |
| Anode current                        | $I_a$     | 0.82 | 1.16 | mA        |
| Anode current                        | $I_{a'}$  | 4.5  | 6.3  | mA        |
| Voltage gain                         | $V_o/V_i$ | 11   | 11   | -         |
| Output voltage ( $I_g = 0.3 \mu A$ ) | $V_o$     | 13   | 20   | $V_{RMS}$ |
| Total distortion                     | $d_{tot}$ | 1.5  | 1.5  | %         |

LIMITING VALUES (Design centre rating system) (each unit)

|  |           |      |      |           |
|--|-----------|------|------|-----------|
| Anode voltage  | $V_{a0}$  | max. | 550  | V         |
|  | $V_a$     | max. | 300  | V         |
| Anode dissipation  | $W_a$     | max. | 2.75 | W         |
| Cathode current  | $I_k$     | max. | 20   | mA        |
| Grid voltage   | $-V_g$    | max. | 100  | V         |
| , peak   | $-V_{gp}$ | max. | 250  | V         |
| Grid resistor (automatic bias)                                   | $R_g$     | max. | 1    | $M\Omega$ |
| Cathode to heater voltage  | $V_{kf}$  | max. | 180  | V         |
| Cathode to heater circuit resistance in phase splitting circuits | $R_{kf}$  | max. | 150  | $k\Omega$ |

**REMARK**

This tube can be used without precautions against microphony in equipment in which  $V_i \geq 10$  mV for an output of 50 mW of the output tube (or  $V_i \geq 100$  mV for 5 W output) provided that the average acceleration of the tube is not greater than indicated in the section "Microphonic effect" of the "Application Directions". When the centre tap of the heater transformer has been earthed,  $R_g \leq 0.3$  M $\Omega$  and  $R_k$  is sufficiently decoupled, the disturbance level for hum and noise will then be better than 60 dB below 100 mV.



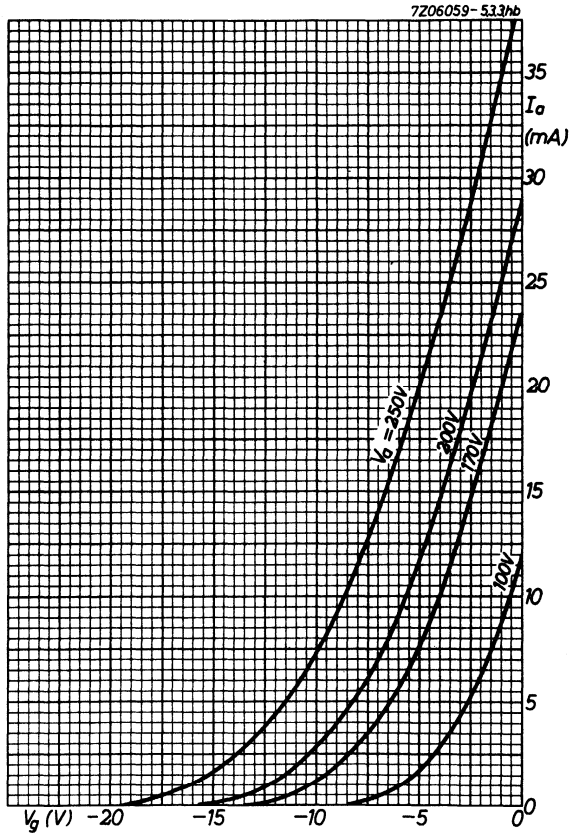

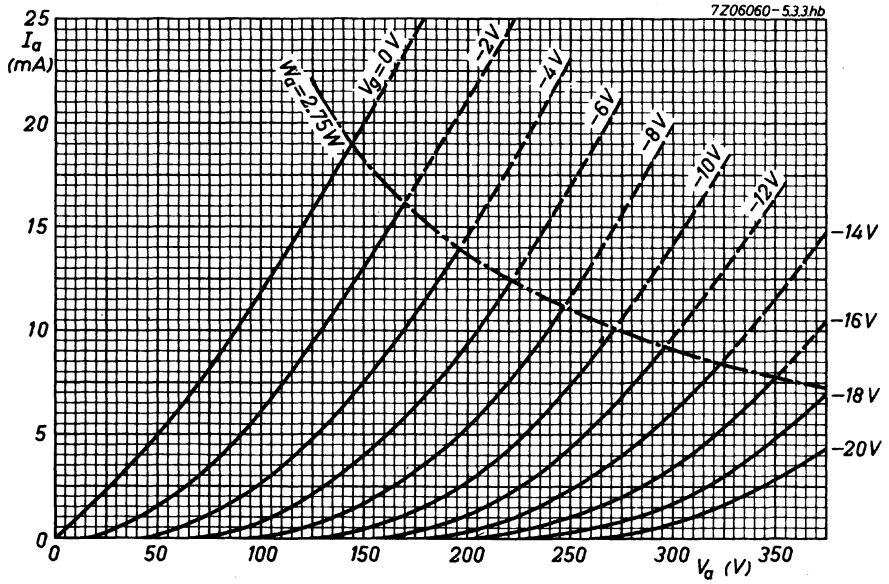

## A.F. DOUBLE TRIODE

Double triode intended for use as A.F. amplifier.

| QUICK REFERENCE DATA<br>(each unit) |       |     |      |
|-------------------------------------|-------|-----|------|
| Anode current                       | $I_a$ | 1.2 | mA   |
| Transconductance                    | $S$   | 1.6 | mA/V |
| Amplification factor                | $\mu$ | 100 | -    |

**HEATING:** Indirect by A.C. or D.C.; series or parallel supply

|                |       |              |          |    |
|----------------|-------|--------------|----------|----|
| Heater voltage | $V_f$ | 6.3          | 12.6     | V  |
| Heater current | $I_f$ | 300          | 150      | mA |
|                |       | pins 9-(4+5) | pins 4-5 |    |

### DIMENSIONS AND CONNECTIONS

Dimensions in mm

Base: Noval

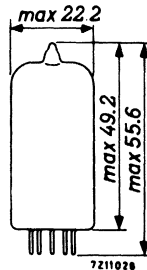
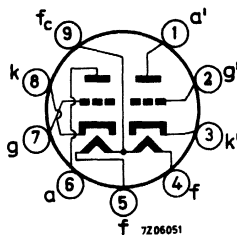

### REMARK

With  $V_f$  applied to pins 9 and 4+5 and the centre tap of the heater transformer connected to earth, the triode section connected to pins 6, 7 and 8 is the more favourable section of the tube with respect to hum.

**CAPACITANCES**

|                          |              |              |
|--------------------------|--------------|--------------|
| Grid to all except anode | $C_{g(a)}$   | 1.6 pF       |
|                          | $C_{g'(a')}$ | 1.6 pF       |
| Anode to all except grid | $C_{a(g)}$   | 0.33 pF      |
|                          | $C_{a'(g')}$ | 0.23 pF      |
| Anode to grid            | $C_{ag}$     | 1.6 pF       |
|                          | $C_{a'g'}$   | 1.6 pF       |
| Grid to heater           | $C_{gf}$     | max. 0.15 pF |
|                          | $C_{g'f}$    | max. 0.15 pF |
| Anode to anode           | $C_{aa'}$    | max. 1.2 pF  |
| Anode to grid other unit | $C_{ag'}$    | max. 0.11 pF |
| Grid to anode other unit | $C_{ga'}$    | max. 0.1 pF  |
| Grid to grid             | $C_{gg'}$    | max. 0.01 pF |

**TYPICAL CHARACTERISTICS**

|                      |       |      |      |            |
|----------------------|-------|------|------|------------|
| Anode voltage        | $V_a$ | 100  | 250  | V          |
| Grid voltage         | $V_g$ | -1.0 | -2.0 | V          |
| Anode current        | $I_a$ | 0.5  | 1.2  | mA         |
| Transconductance     | $S$   | 1.25 | 1.6  | mA/V       |
| Amplification factor | $\mu$ | 100  | 100  | -          |
| Internal resistance  | $R_i$ | 80   | 62.5 | k $\Omega$ |

**OPERATING CHARACTERISTICS**

As A.F. amplifier, one unit

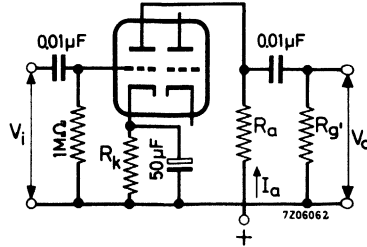

|                                      |           |      |      |      |      |      |                  |
|--------------------------------------|-----------|------|------|------|------|------|------------------|
| Supply voltage                       | $V_b$     | 200  | 250  | 300  | 350  | 400  | V                |
| Anode resistor                       | $R_a$     | 47   | 47   | 47   | 47   | 47   | k $\Omega$       |
| Grid resistor next stage             | $R_{g'}$  | 150  | 150  | 150  | 150  | 150  | k $\Omega$       |
| Cathode resistor                     | $R_k$     | 1500 | 1200 | 1000 | 820  | 680  | $\Omega$         |
| Anode current                        | $I_a$     | 0.86 | 1.18 | 1.55 | 1.98 | 2.45 | mA               |
| Voltage gain                         | $V_o/V_i$ | 34   | 37.5 | 40   | 42.5 | 44   | -                |
| Output voltage ( $I_g = 0.3 \mu A$ ) | $V_o$     | 18   | 23   | 26   | 33   | 37   | V <sub>RMS</sub> |
| Total distortion                     | $d_{tot}$ | 8.5  | 7.0  | 5.0  | 4.4  | 3.6  | %                |
| Supply voltage                       | $V_b$     | 200  | 250  | 300  | 350  | 400  | V                |
| Anode resistor                       | $R_a$     | 100  | 100  | 100  | 100  | 100  | k $\Omega$       |
| Grid resistor next stage             | $R_{g'}$  | 330  | 330  | 330  | 330  | 330  | k $\Omega$       |
| Cathode resistor                     | $R_k$     | 1800 | 1500 | 1200 | 1000 | 820  | $\Omega$         |
| Anode current                        | $I_a$     | 0.65 | 0.86 | 1.11 | 1.40 | 1.72 | mA               |
| Voltage gain                         | $V_o/V_i$ | 50   | 54.5 | 57   | 61   | 63   | -                |
| Output voltage ( $I_g = 0.3 \mu A$ ) | $V_o$     | 20   | 26   | 30   | 36   | 38   | V <sub>RMS</sub> |
| Total distortion                     | $d_{tot}$ | 4.8  | 3.9  | 2.7  | 2.2  | 1.7  | %                |
| Supply voltage                       | $V_b$     | 200  | 250  | 300  | 350  | 400  | V                |
| Anode resistor                       | $R_a$     | 220  | 220  | 220  | 220  | 220  | k $\Omega$       |
| Grid resistor next stage             | $R_{g'}$  | 680  | 680  | 680  | 680  | 680  | k $\Omega$       |
| Cathode resistor                     | $R_k$     | 3.3  | 2.7  | 2.2  | 1.5  | 1.2  | k $\Omega$       |
| Anode current                        | $I_a$     | 0.36 | 0.48 | 0.63 | 0.85 | 1.02 | mA               |
| Voltage gain                         | $V_o/V_i$ | 56   | 66.5 | 72   | 75.5 | 76.5 | -                |
| Output voltage ( $I_g = 0.3 \mu A$ ) | $V_o$     | 24   | 28   | 36   | 37   | 38   | V <sub>RMS</sub> |
| Total distortion                     | $d_{tot}$ | 4.6  | 3.4  | 2.6  | 1.6  | 1.1  | %                |

As phase inverter

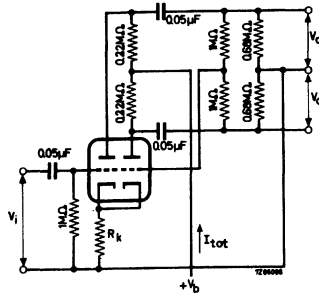

|                                      |           |      |      |           |
|--------------------------------------|-----------|------|------|-----------|
| Supply voltage                       | $V_b$     | 250  | 350  | V         |
| Cathode resistor                     | $R_k$     | 1200 | 820  | $\Omega$  |
| Total current                        | $I_{tot}$ | 1.08 | 1.70 | mA        |
| Voltage gain                         | $V_o/V_i$ | 58   | 62   | -         |
| Output voltage ( $I_g = 0.3 \mu A$ ) | $V_o$     | 35   | 45   | $V_{RMS}$ |
| Total distortion                     | $d_{tot}$ | 5.5  | 3.5  | %         |

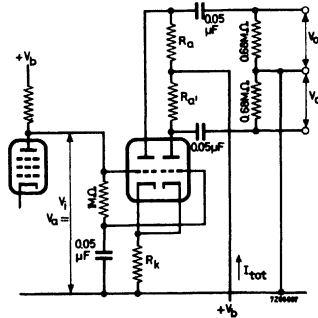

|                                      |           |     |     |           |
|--------------------------------------|-----------|-----|-----|-----------|
| Supply voltage                       | $V_b$     | 250 | 350 | V         |
| Anode voltage                        | $V_a$     | 65  | 90  | V         |
| Total current                        | $I_{tot}$ | 1   | 1.2 | mA        |
| Cathode resistor                     | $R_k$     | 68  | 82  | $k\Omega$ |
| Anode resistor                       | $R_a$     | 100 | 150 | $k\Omega$ |
| Anode resistor                       | $R_{a'}$  | 100 | 150 | $k\Omega$ |
| Voltage gain                         | $V_o/V_i$ | 25  | 27  | -         |
| Output voltage ( $I_g = 0.3 \mu A$ ) | $V_o$     | 20  | 35  | $V_{RMS}$ |
| Total distortion                     | $d_{tot}$ | 1.8 | 1.8 | %         |

**LIMITING VALUES** (Design centre rating system)

|   |          |                     |
|---|----------|---------------------|
| Anode voltage   | $V_{a0}$ | max. 550 V          |
|   | $V_a$    | max. 300 V          |
| Anode dissipation   | $W_a$    | max. 1 W            |
| Cathode current   | $I_k$    | max. 8 mA           |
| Grid voltage  | $-V_g$   | max. 50 V           |
| Grid resistor (automatic bias)                                      | $R_g$    | max. 2 M $\Omega$   |
| Cathode to heater voltage   | $V_{kf}$ | max. 180 V          |
| Cathode to heater circuit<br>resistance in phase splitting circuits | $R_{kf}$ | max. 150 k $\Omega$ |

**REMARK**

Microphony and hum

This tube can be used without special precautions against microphony in equipment in which the input voltage  $V_i \geq 5$  mV for an output of 50 mW (or 50 mV for an output of 5 W) provided the average acceleration of the tube is not greater than indicated in the section "Microphonic effect" of the "Application directions". In this case the disturbance level for hum and noise will be better than -60 dB when the centre tap of the heater has been earthed,  $R_g \leq 0.5$  M $\Omega$  and the cathode resistor is sufficiently decoupled.

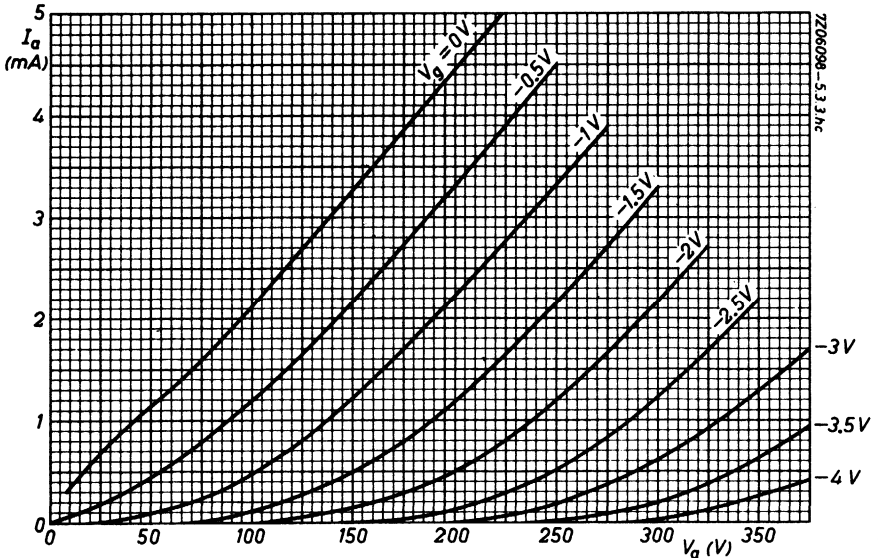

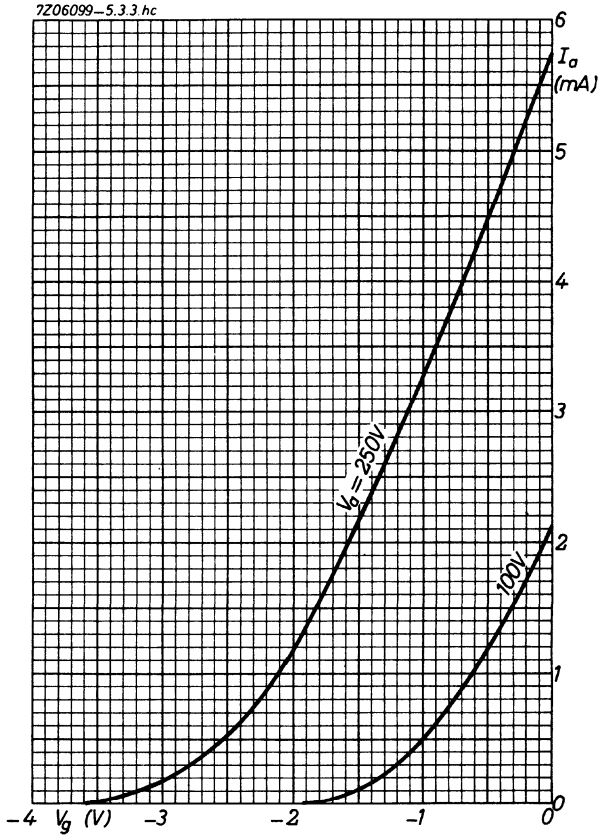



## R.F. DOUBLE TRIODE

Double triode intended for use as R.F. and A.F. amplifier and self oscillating mixer.

| QUICK REFERENCE DATA<br>(each unit) |       |          |
|-------------------------------------|-------|----------|
| Anode current                       | $I_a$ | 10 mA    |
| Transconductance                    | $S$   | 6.1 mA/V |
| Amplification factor                | $\mu$ | 55 -     |

**HEATING:** Indirect by A.C. or D.C.; parallel supply

|                |       |        |
|----------------|-------|--------|
| Heater voltage | $V_f$ | 6.3 V  |
| Heater current | $I_f$ | 435 mA |

### DIMENSIONS AND CONNECTIONS

Dimensions in mm

Base: Noval

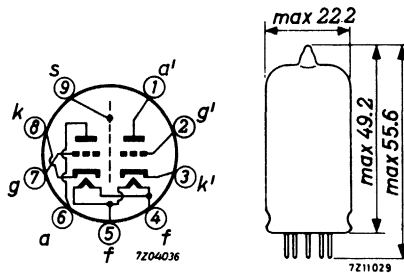

## CAPACITANCES

|   |               |               |
|---|---------------|---------------|
| Anode to grid   | $C_{ag}$      | 1.5 pF        |
|   | $C_{a'g'}$    | 1.5 pF        |
| Anode to cathode  | $C_{ak}$      | 0.17 pF       |
|   | $C_{a'k'}$    | 0.18 pF       |
| Anode to cathode + heater + screen  | $C_{a/kfs}$   | 1.2 pF        |
|   | $C_{a'/k'fs}$ | 1.2 pF        |
| Grid to cathode + heater + screen   | $C_{g/kfs}$   | 3.1 pF        |
|   | $C_{g'/k'fs}$ | 3.1 pF        |
| Anode to cathode + heater + screen<br>with external screen of 22.5 mm diam. | $C_{a/kfs}$   | 1.8 pF        |
|   | $C_{a'/k'fs}$ | 1.8 pF        |
| Anode to anode  | $C_{aa'}$     | max. 0.04 pF  |
| Grid to grid  | $C_{gg'}$     | max. 0.003 pF |
| Anode to grid other unit  | $C_{ag'}$     | max. 0.008 pF |
| Grid to anode other unit  | $C_{ga'}$     | max. 0.008 pF |
| Anode to anode with external<br>screen of 22.5 mm diam.                     | $C_{aa'}$     | max. 0.008 pF |
| Anode to cathode other unit   | $C_{ak'}$     | max. 0.008 pF |
| Grid to cathode other unit  | $C_{gk'}$     | max. 0.003 pF |
| Cathode to anode other unit   | $C_{ka'}$     | max. 0.008 pF |
| Cathode to grid other unit  | $C_{kg'}$     | max. 0.003 pF |

## TYPICAL CHARACTERISTICS

|                      |       |          |
|----------------------|-------|----------|
| Anode voltage        | $V_a$ | 250 V    |
| Grid voltage         | $V_g$ | -2.7 V   |
| Anode current        | $I_a$ | 10 mA    |
| Transconductance     | $S$   | 6.1 mA/V |
| Amplification factor | $\mu$ | 55 -     |

## REMARK

### Microphony

This tube can be used without special precautions against microphony in A.F. applications in which the input voltage  $V_i \geq 5$  mV for an output of 50 mW (or 50 mV for an output of 5 W) provided the peak acceleration of the tube is not greater than indicated in the section "Microphony" of the "General Operational Recommendations".

## OPERATING CHARACTERISTICS

As R.F. amplifier

|                                     |          |               |
|-------------------------------------|----------|---------------|
| Supply voltage                      | $V_b$    | 250 V         |
| Anode resistor                      | $R_a$    | 1.8 $k\Omega$ |
| Anode voltage                       | $V_a$    | 230 V         |
| Cathode resistor                    | $R_k$    | 200 $\Omega$  |
| Grid voltage                        | $V_g$    | -2.2 V        |
| Anode current                       | $I_a$    | 10.8 mA       |
| Transconductance                    | $S$      | 6.8 mA/V      |
| Internal resistance                 | $R_i$    | 8.3 $k\Omega$ |
| Grid input resistance (f = 100 MHz) | $r_g$    | 4.7 $k\Omega$ |
| Equivalent noise resistance         | $R_{eq}$ | 580 $\Omega$  |

As self-oscillating mixer

|                                     |           |               |
|-------------------------------------|-----------|---------------|
| Supply voltage                      | $V_b$     | 250 V         |
| Anode resistor                      | $R_a$     | 12 $k\Omega$  |
| Grid resistor                       | $R_g$     | 1 $M\Omega$   |
| Oscillator voltage                  | $V_{osc}$ | 3.0 $V_{RMS}$ |
| Anode current                       | $I_a$     | 6 mA          |
| Conversion conductance              | $S_c$     | 3 mA/V        |
| Internal resistance                 | $R_i$     | 18 $k\Omega$  |
| Grid input resistance (f = 100 MHz) | $r_g$     | 15 $k\Omega$  |

**LIMITING VALUES** (Design centre rating system) (Each unit unless otherwise stated)

|   |              |                  |
|---|--------------|------------------|
| Anode voltage                           | $V_{a0}$     | max. 550 V       |
|   | $V_a$        | max. 300 V       |
| Anode dissipation                       | $W_a$        | max. 2.5 W       |
| Anode dissipation, total for both units | $W_a + W_a'$ | max. 4.5 W       |
| Cathode current                         | $I_k$        | max. 15 mA       |
| Grid voltage                            | $-V_g$       | max. 100 V       |
| Grid resistor                           | $R_g$        | max. 1 $M\Omega$ |
| Cathode to heater voltage               | $V_{kf}$     | max. 90 V        |

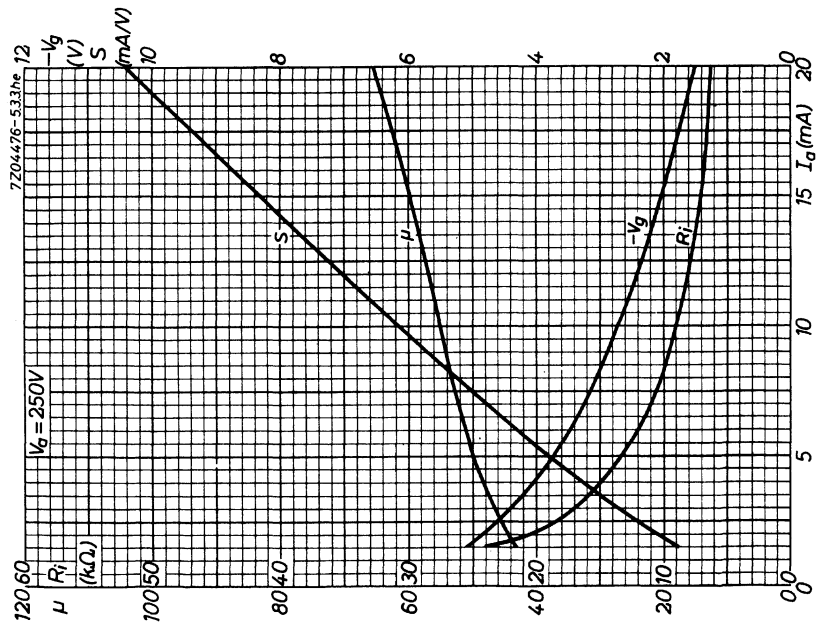
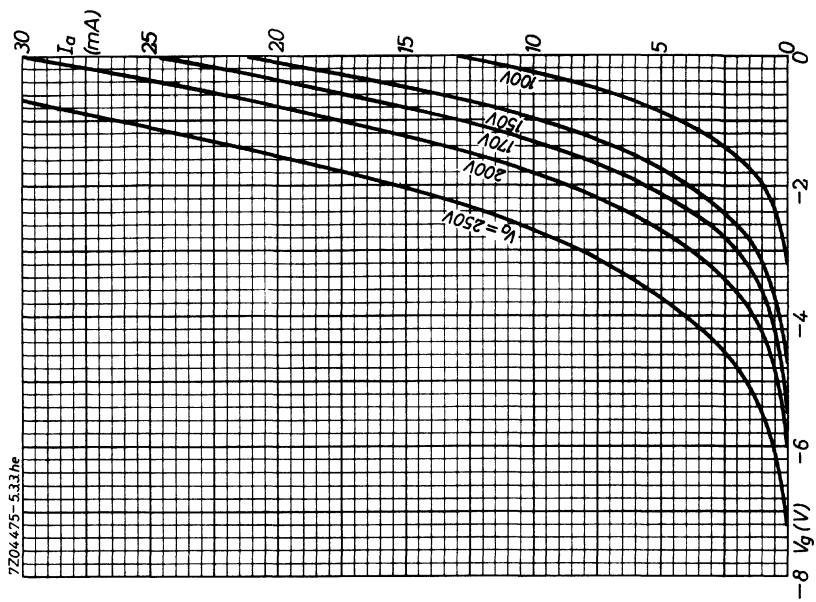

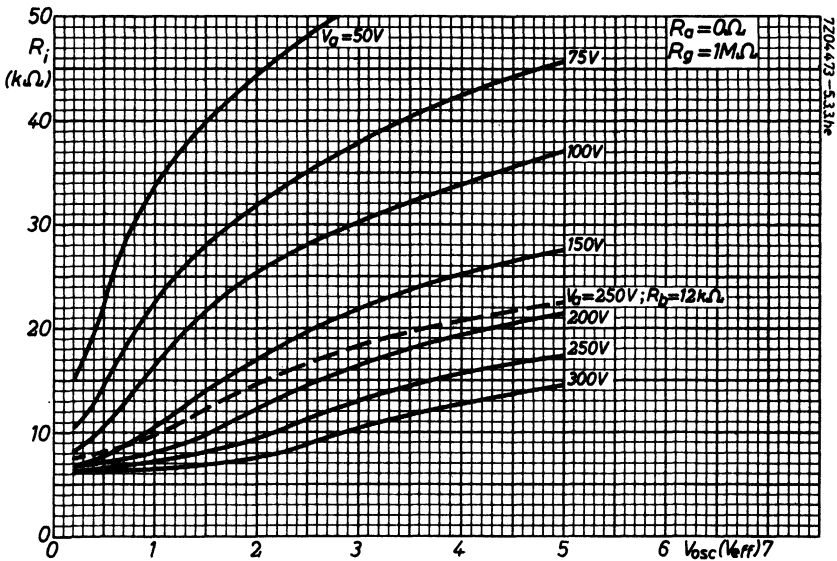
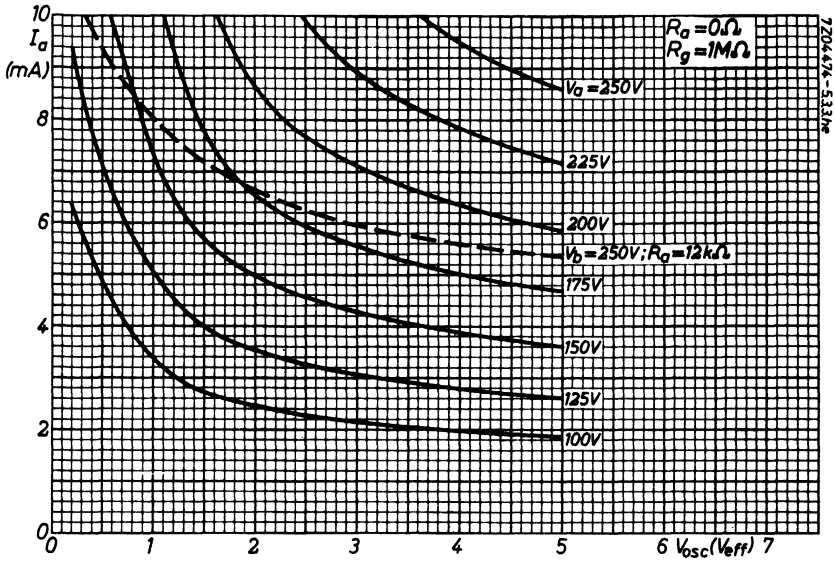

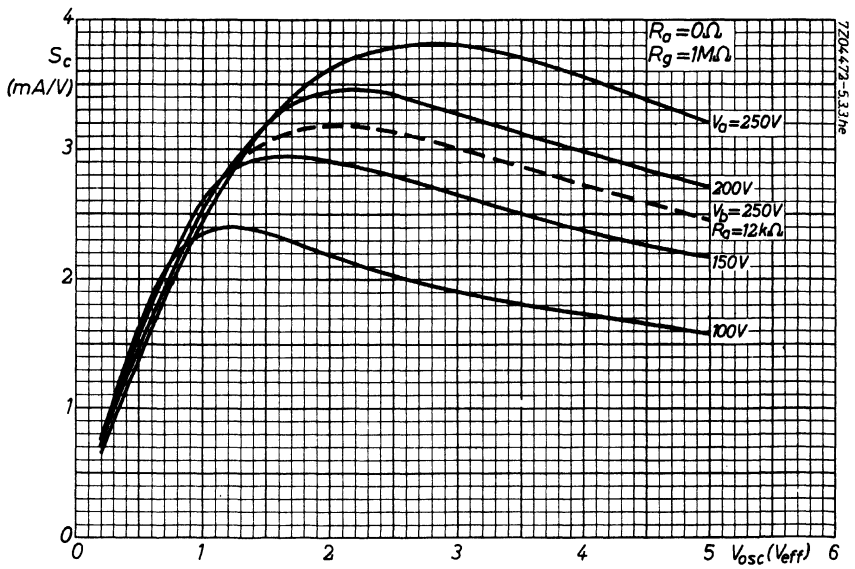
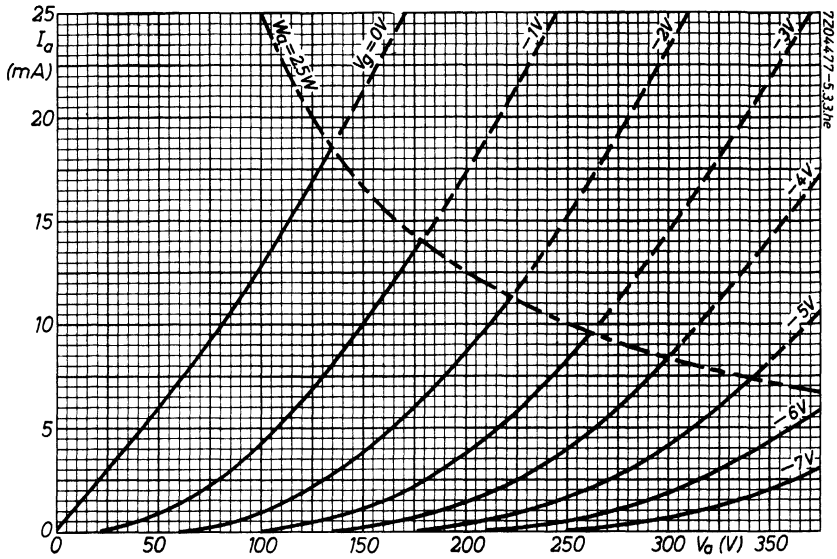

## R.F. DOUBLE TRIODE

Double triode intended for use as cascode amplifier in tuners for television receivers.

**HEATING:** Indirect by A.C. or D.C.; parallel supply

Heater voltage

$V_f$  6.3 V

Heater current

$I_f$  365 mA

-----  
For further data and curves please refer to PCC88  
-----





## R.F. DOUBLE TRIODE

Double triode with variable transconductance intended for use as V.H.F. cascade amplifier in television receivers.

**HEATING:** Indirect by A.C. or D.C.; parallel supply

|                |       |        |
|----------------|-------|--------|
| Heater voltage | $V_f$ | 6.3 V  |
| Heater current | $I_f$ | 365 mA |

**LIMITING VALUES** (Design centre rating system)

|                           |                          |                          |
|---------------------------|--------------------------|--------------------------|
| Cathode to heater voltage | $V_{kf}$                 | max. 50 V                |
|                           | $V_{k'f}(k \text{ pos})$ | max. 150 V <sup>1)</sup> |

-----  
 For further data and curves of this type  
 please refer to type PCC189  
 -----

<sup>1)</sup> D.C. component max. 130 V.



## TRIODE-PENTODE

Triode-pentode with separate cathodes intended for use as frequency changer in television receivers.

**HEATING:** Indirect by A.C. or D.C.; parallel supply

|                |       |            |    |
|----------------|-------|------------|----|
| Heater voltage | $V_f$ | <u>6.3</u> | V  |
| Heater current | $I_f$ | 430        | mA |

**LIMITING VALUES** (Design centre rating system)

Triode section

Cathode to heater voltage  $V_{kf}$  max. 100 V

Pentode section

Cathode to heater voltage  $V_{kf}$  max. 100 V

-----  
 For further data and curves  
 please refer to PCF80  
 -----



## TRIODE-PENTODE

Triode-pentode intended for use as frequency changer in V.H.F. television tuners.

**HEATING:** Indirect by A.C. or D.C.; parallel supply

|                |       |        |
|----------------|-------|--------|
| Heater voltage | $V_f$ | 6.3 V  |
| Heater current | $I_f$ | 390 mA |

**LIMITING VALUES** (Design centre rating system)

Triode section

Cathode to heater voltage  $V_{kf}$  max. 100 V

Pentode section

Cathode to heater voltage  $V_{kf}$  max. 100 V

-----  
 For further data and curves  
 please refer to PCF86  
 -----



## TRIODE-PENTODE

Triode-pentode intended for use in television receivers; triode section as limiter, noise detector, A.G.C. amplifier, sync. separator and pulse-amplifier; pentode section as sound I.F. amplifier and video I.F. amplifier.

**HEATING:** Indirect by A.C. or D.C.; parallel supply

Heater voltage

$V_f$  6.3 V

Heater current

$I_f$  410 mA

-----  
For further data and curves  
please refer to type PCF200  
-----





## TRIODE-PENTODE

Triode-pentode intended for use in T.V. receivers; triode section as line-blocking oscillator, part of a multivibrator, sync separator, pulse amplifier or A.G.C. delay diode; pentode section with remote cut-off as video I.F. amplifier.

**HEATING:** Indirect by A.C. or D.C.; parallel supply

Heater voltage

$V_f$  6.3 V

Heater current

$I_f$  410 mA

-----  
For further data and curves of this type  
please refer to type PCF201  
-----



**TRIODE-PENTODE**

High transconductance triode and R.F. pentode intended for use as frequency changer in V.H.F. T.V. tuners.

**HEATING:** Indirect by A.C. or D.C.; parallel supply

Heater voltage

$\frac{V_f}{6.3}$  V

Heater current

$\frac{I_f}{0.41}$  A

-----  
For further data and curves of this type  
please refer to type PCF801  
-----



**TRIODE-PENTODE**

Triode-pentode; triode section intended for use as reactance tube, pentode section intended for use as sine wave oscillator or pulse shaper in television receivers.

**HEATING:** Indirect by A.C. or D.C.; parallel supply

|                |       |     |    |
|----------------|-------|-----|----|
| Heater voltage | $V_f$ | 6.3 | V  |
| Heater current | $I_f$ | 430 | mA |

**LIMITING VALUES**Pentode section

Cathode to heater voltage  $V_{kf}$  max. 100 V

Triode section

Cathode to heater voltage  $V_{kf}$  max. 100 V

For further data and curves  
please refer to type PCF802



## TRIODE-HEPTODE

Triode-heptode. Heptode section intended for use as mixer, R.F. - or I.F. amplifier. Triode section intended for use as oscillator in A.M./F.M. receivers.

| QUICK REFERENCE DATA   |                |          |
|------------------------|----------------|----------|
| <u>Triode section</u>  |                |          |
| Anode current          | $I_a$          | 13.5 mA  |
| Transconductance       | $S$            | 3.7 mA/V |
| Amplification factor   | $\mu$          | 22 -     |
| <u>Heptode section</u> |                |          |
| Anode current          | $I_a$          | 11 mA    |
| Transconductance       | $S$            | 4.5 mA/V |
| Amplification factor   | $\mu_{g_2g_1}$ | 25 -     |

**HEATING:** Indirect by A.C. or D.C.; series or parallel supply

|                |       |        |
|----------------|-------|--------|
| Heater voltage | $V_f$ | 6.3 V  |
| Heater current | $I_f$ | 300 mA |

### DIMENSIONS AND CONNECTIONS

Dimensions in mm

Base: Noval

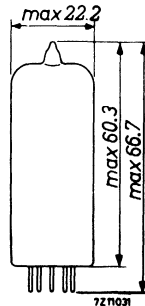
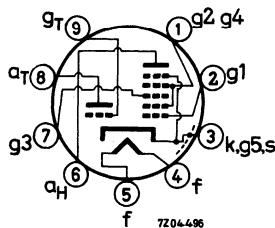

**CAPACITANCES**

Triode section

|                          |            |              |
|--------------------------|------------|--------------|
| Grid to all except anode | $C_{g(a)}$ | 2.6 pF       |
| Anode to all except grid | $C_{a(g)}$ | 2.1 pF       |
| Anode to grid            | $C_{ag}$   | 1.0 pF       |
| Grid to heater           | $C_{gf}$   | max. 0.02 pF |

Heptode section

|                               |              |              |
|-------------------------------|--------------|--------------|
| Grid No.1 to all except anode | $C_{g_1(a)}$ | 4.8 pF       |
| Anode to all except grid No.1 | $C_{a(g_1)}$ | 7.9 pF       |
| Anode to grid No.1            | $C_{ag_1}$   | max.0.006 pF |
| Grid No.1 to heater           | $C_{g_1f}$   | max. 0.17 pF |
| Grid No.3 to all              | $C_{g_3}$    | 6 pF         |
| Grid No.1 to grid No.3        | $C_{g_1g_3}$ | max. 0.3 pF  |
| Grid No.3 to heater           | $C_{g_3f}$   | max. 0.06 pF |

Between heptode and triode sections

|   |                  |              |
|---|------------------|--------------|
| Anode heptode to anode triode                   | $C_{aH^aT}$      | 0.20 pF      |
| Anode heptode to grid triode                    | $C_{aH^gT}$      | max. 0.09 pF |
| Grid No.1 heptode to anode triode               | $C_{g_1H^aT}$    | max. 0.06 pF |
| Grid No.1 heptode to grid triode                | $C_{g_1H^gT}$    | max. 0.17 pF |
| Grid No.1 heptode to grid triode<br>+ grid No.3 | $C_{g_1H/gTg_3}$ | max. 0.45 pF |
| Anode heptode to grid triode<br>+ grid No.3     | $C_{aH/gTg_3}$   | max. 0.35 pF |



## TYPICAL CHARACTERISTICS

Triode section

|                      |       |          |
|----------------------|-------|----------|
| Anode voltage        | $V_a$ | 100 V    |
| Grid voltage         | $V_g$ | 0 V      |
| Anode current        | $I_a$ | 13.5 mA  |
| Transconductance     | S     | 3.7 mA/V |
| Amplification factor | $\mu$ | 22 -     |

Heptode section

|                          |              |             |
|--------------------------|--------------|-------------|
| Anode voltage            | $V_a$        | 160 V       |
| Grid No.3 voltage        | $V_{g3}$     | 0 V         |
| Grids No.2 and 4 voltage | $V_{g2+4}$   | 100 V       |
| Grid No.1 current        | $I_{g1}$     | 0.5 $\mu$ A |
| Grid No.1 voltage        | $V_{g1}$     | -0.5 V      |
| Anode current            | $I_a$        | 11 mA       |
| Grids No.2 and 4 current | $I_{g2+4}$   | 7 mA        |
| Transconductance         | S            | 4.5 mA/V    |
| Amplification factor     | $\mu_{g2g1}$ | 25 -        |

**OPERATING CHARACTERISTICS**

Heptode section as mixer <sup>1)</sup>

|                                  |               |      |                         |
|----------------------------------|---------------|------|-------------------------|
| Supply voltage                   | $V_b$         | 250  | V                       |
| Anode resistor                   | $R_a$         | 8.2  | $k\Omega$               |
| Grids No.2 and 4 resistor        | $R_{g_2+4}$   | 22   | $k\Omega$               |
| Grid triode + grid No.3 resistor | $R_{g_T+g_3}$ | 47   | $k\Omega$               |
| Grid triode + grid No.3 current  | $I_{g_T+g_3}$ | 200  | $\mu A$                 |
| Grid No.1 current                | $I_{g_1}$     | 0.5  | - $\mu A$ <sup>2)</sup> |
| Grid No.1 voltage                | $V_{g_1}$     | -    | -28 V                   |
| Anode voltage                    | $V_a$         | 225  | 240 V                   |
| Grids No.2 and 4 voltage         | $V_{g_2+4}$   | 78   | 235 V                   |
| Anode current                    | $I_a$         | 3.3  | - mA                    |
| Grids No.2 and 4 current         | $I_{g_2+4}$   | 7.8  | - mA                    |
| Conversion conductance           | $S_c$         | 1100 | 11 $\mu A/V$            |
| Internal resistance              | $R_i$         | 0.8  | min. 3 $M\Omega$        |
| Equivalent noise resistance      | $R_{eq}$      | 30   | - $k\Omega$             |

1) Triode operating with  $V_b = 250$  V,  $R_a = 33$   $k\Omega$ ,  $V_{osc} = 8$   $V_{RMS}$ .

2) Grid current bias obtained with  $R_{g_1} = 1$   $M\Omega$  and with zero volts a.g.c. voltage; resulting grid one voltage: -0.5 V.

## OPERATING CHARACTERISTICS (continued)

Heptode section as R.F. or I.F. amplifier

|                             |                |      |                    |
|-----------------------------|----------------|------|--------------------|
| Supply voltage              | $V_b$          | 250  | V                  |
| Anode resistor              | $R_a$          | 8.2  | k $\Omega$         |
| Grid No.3 voltage           | $V_{g_3}$      | 0    | V                  |
| Grids No.2 and 4 resistor   | $R_{g_{2+4}}$  | 22   | k $\Omega$         |
| Grid No.1 current           | $I_{g_1}$      | 0.5  | - $\mu$ A          |
| Grid No.1 voltage           | $V_{g_1}$      | -    | -35 V 1)           |
| Anode voltage               | $V_a$          | 160  | 248 V              |
| Grids No.2 and 4 voltage    | $V_{g_{2+4}}$  | 96   | 245 V              |
| Anode current               | $I_a$          | 11   | - mA               |
| Grids No.2 and 4 current    | $I_{g_{2+4}}$  | 7    | - mA               |
| Transconductance            | S              | 4500 | 45 $\mu$ A/V       |
| Internal resistance         | $R_i$          | 0.24 | min. 10 M $\Omega$ |
| Amplification factor        | $\mu_{g_2g_1}$ | 25   | - -                |
| Equivalent noise resistance | $R_{eq}$       | 4.5  | - k $\Omega$       |

Triode section as oscillator

|                                  |              |      |            |
|----------------------------------|--------------|------|------------|
| Supply voltage                   | $V_b$        | 250  | V          |
| Anode resistor                   | $R_a$        | 33   | k $\Omega$ |
| Grid triode + grid No.3 resistor | $R_{gT+g_3}$ | 47   | k $\Omega$ |
| Grid triode + grid No.3 current  | $I_{gT+g_3}$ | 200  | $\mu$ A    |
| Anode current                    | $I_a$        | 4.5  | mA         |
| Effective transconductance       | $S_{eff}$    | 0.65 | mA/V       |

1) Grid current bias obtained with  $R_{g_1} = 1$  M $\Omega$  and with zero volts a.g.c. voltage; resulting grid No.1 voltage: -0.5 V.

## LIMITING VALUES (Design centre rating system)

### Heptode section

|  |                 |                   |
|--|-----------------|-------------------|
| Anode voltage  | $V_{a_0}$       | max. 550 V        |
|  | $V_a$           | max. 300 V        |
| Anode dissipation  | $W_a$           | max. 2.0 W        |
| Grids No.2 and 4 voltage   | $V_{g_{2+4_0}}$ | max. 550 V        |
|  | $V_{g_{2+4}}$   | max. 125 V        |
| Grids No.2 and 4 voltage ( $I_a$ max. 1 mA)                          | $V_{g_{2+4}}$   | max. 300 V        |
| Grids No.2 and 4 dissipation   | $W_{g_{2+4}}$   | max. 0.8 W        |
| Cathode current  | $I_k$           | max. 18 mA        |
| Grid No.1 resistor   | $R_{g_1}$       | max. 3 $M\Omega$  |
| Grid No.3 resistor   | $R_{g_3}$       | max. 20 $k\Omega$ |
| Grid No.3 resistor<br>grid No.3 directly connected to<br>grid triode | $R_{g_3}$       | max. 3 $M\Omega$  |
| Cathode to heater voltage  | $V_{kf}$        | max. 100 V        |

### Triode section

|                           |           |                  |
|---------------------------|-----------|------------------|
| Anode voltage             | $V_{a_0}$ | max. 550 V       |
|                           | $V_a$     | max. 250 V       |
| Anode dissipation         | $W_a$     | max. 0.8 W       |
| Cathode current           | $I_k$     | max. 6.5 mA      |
| Grid resistor             | $R_g$     | max. 3 $M\Omega$ |
| Cathode to heater voltage | $V_{kf}$  | max. 100 V       |

**TRIODE-HEPTODE**

Triode-heptode intended for use as mixer in car radio sets and as sync separator in TV receivers.

**QUICK REFERENCE DATA**

|  |            |     |      |              |
|--|------------|-----|------|--------------|
| <u>Triode</u>                            |            |     |      |              |
| Anode voltage                            | $V_a$      | 25  | 12.6 | 6.3 V        |
| Anode current                            | $I_a$      | 2   | 0.75 | 0.3 mA       |
| Transconductance                         | S          | 2.2 | 1.4  | 0.8 mA/V     |
| Amplification factor                     | $\mu$      | 20  | 18.3 | 14.6 -       |
| <u>Heptode as mixer</u>                  |            |     |      |              |
| Anode voltage                            | $V_a$      | 25  | 12.6 | 6.3 V        |
| Grids No.2 and 4 voltage                 | $V_{g2+4}$ | 25  | 12.6 | 6.3 V        |
| Conversion conductance                   | $S_c$      | 450 | 220  | 90 $\mu A/V$ |
| <u>Heptode as R.F. or I.F. amplifier</u> |            |     |      |              |
| Anode voltage                            | $V_a$      | 25  | 12.6 | 6.3 V        |
| Grids No.2 and 4 voltage                 | $V_{g2+4}$ | 25  | 12.6 | 6.3 V        |
| Transconductance                         | S          | 1.5 | 0.75 | 0.35 mA/V    |

**HEATING:** Indirect by A.C. or D.C.; parallel or series supply

Heater voltage

$V_f$  6.3 V

Heater current

$I_f$  300 mA

**DIMENSIONS AND CONNECTIONS**

Dimensions in mm

Base: Noval

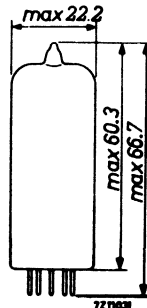
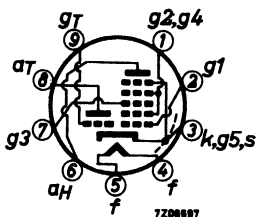

**CAPACITANCES**

Triode section

|                          |            |        |
|--------------------------|------------|--------|
| Anode to all except grid | $C_{a(g)}$ | 2.1 pF |
| Grid to all except anode | $C_{g(a)}$ | 2.6 pF |
| Anode to grid            | $C_{ag}$   | 1.0 pF |

Heptode section

|                        |              |               |
|------------------------|--------------|---------------|
| Anode to all           | $C_a$        | 7.9 pF        |
| Grid No.1 to all       | $C_{g_1}$    | 4.8 pF        |
| Anode to grid No.1     | $C_{ag_1}$   | max. 0.012 pF |
| Grid No.3 to all       | $C_{g_3}$    | 6.0 pF        |
| Grid No.1 to grid No.3 | $C_{g_1g_3}$ | max. 0.3 pF   |

Between heptode and triode sections

|   |                  |              |
|---|------------------|--------------|
| Anode heptode to anode triode                     | $C_{aHaT}$       | 0.20 pF      |
| Anode heptode to grid triode                      | $C_{aHgT}$       | max. 0.09 pF |
| Grid No.1 heptode to anode triode                 | $C_{g_1HaT}$     | max. 0.06 pF |
| Grid No.1 heptode to grid triode                  | $C_{g_1HgT}$     | max. 0.17 pF |
| Grid No.1 heptode to grid triode<br>and grid No.3 | $C_{g_1H/gTg_3}$ | max. 0.45 pF |
| Anode heptode to grid triode<br>and grid No.3     | $C_{aH/gTg_3}$   | max. 0.35 pF |

**TYPICAL CHARACTERISTICS**

Triode section

|                      |       |     |      |      |      |
|----------------------|-------|-----|------|------|------|
| Anode voltage        | $V_a$ | 25  | 12.6 | 6.3  | V    |
| Grid voltage         | $V_g$ | 1)  | 1)   | 1)   | -    |
| Anode current        | $I_a$ | 2   | 0.75 | 0.3  | mA   |
| Transconductance     | $S$   | 2.2 | 1.4  | 0.8  | mA/V |
| Amplification factor | $\mu$ | 20  | 18.3 | 14.6 | -    |

1) Obtained by grid current biasing:  $R_g = 47 \text{ k}\Omega$ .

## OPERATING CHARACTERISTICS

### Heptode as mixer, circuit fig.1.

|                          |               |      |      |     |           |
|--------------------------|---------------|------|------|-----|-----------|
| Anode voltage            | $V_a$         | 25   | 12.6 | 6.3 | V         |
| Grids No.2 and 4 voltage | $V_{g_{2+4}}$ | 25   | 12.6 | 6.3 | V         |
| Grid No.1 voltage        | $V_{g_1}$     | 1)   | 1)   | 1)  |           |
| Oscillator voltage       | $V_{osc}$     | 3.5  | 1.7  | 1.1 | $V_{RMS}$ |
| Grid No.3 resistor       | $R_{g_3}$     | 47   | 47   | 47  | $k\Omega$ |
| Grid No.3 current        | $I_{g_3}$     | 40   | 18   | 7   | $\mu A$   |
| Anode current            | $I_a$         | 550  | 170  | 50  | $\mu A$   |
| Grids No.2 and 4 current | $I_{g_{2+4}}$ | 1000 | 300  | 80  | $\mu A$   |
| Conversion conductance   | $S_c$         | 450  | 220  | 90  | $\mu A/V$ |
| Internal resistance      | $R_i$         | 0.5  | 1.5  | 1.3 | $M\Omega$ |

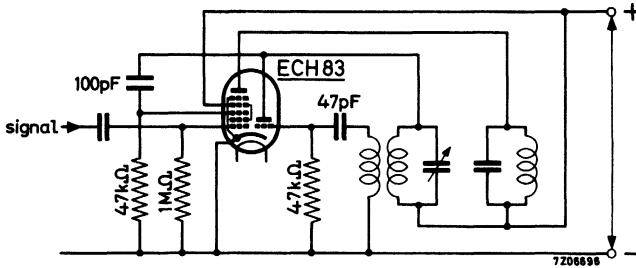

fig. 1

### Heptode as R.F. or I.F. amplifier

|                                   |                 |      |      |      |           |
|-----------------------------------|-----------------|------|------|------|-----------|
| Anode voltage                     | $V_a$           | 25   | 12.6 | 6.3  | V         |
| Grids No.2, No.3 and No.4 voltage | $V_{g_{2+3+4}}$ | 25   | 12.6 | 6.3  | V         |
| Grid No.1 voltage                 | $V_{g_1}$       | 1)   | 1)   | 1)   |           |
| Anode current                     | $I_a$           | 1.25 | 0.4  | 0.11 | mA        |
| Grids No.2, No.3 and 4 current    | $I_{g_{2+3+4}}$ | 0.85 | 0.25 | 0.08 | mA        |
| Transconductance                  | $S$             | 1.5  | 0.75 | 0.35 | mA/V      |
| Internal resistance               | $R_i$           | 0.2  | 0.85 | 0.6  | $M\Omega$ |
| Equivalent noise resistance       | $R_{eq}$        | 5    | 6.5  | 8.5  | $k\Omega$ |

1) Obtained by grid current biasing:  $R_{g_1} = 1 M\Omega$ .

## LIMITING VALUES (Design centre rating system)

### Triode section

|                           |           |                   |
|---------------------------|-----------|-------------------|
| Anode voltage             | $V_{a_0}$ | max. 550 V        |
|                           | $V_a$     | max. 250 V        |
| Anode dissipation         | $W_a$     | max. 0.8 W        |
| Cathode current           | $I_k$     | max. 6.5 mA       |
| Grid resistor             | $R_g$     | max. 3 M $\Omega$ |
| Cathode to heater voltage | $V_{kf}$  | max. 150 V        |
| D.C. component            |           | max. 100 V        |

### Heptode section

|                           |               |                    |
|---------------------------|---------------|--------------------|
| Anode voltage             | $V_{a_0}$     | max. 550 V         |
|                           | $V_a$         | max. 50 V          |
| Grids No.2 and 4 voltage  | $V_{g_{2+4}}$ | max. 50 V          |
| Cathode current           | $I_k$         | max. 5 mA          |
| Grid No.1 resistor        | $R_{g_1}$     | max. 3 M $\Omega$  |
| Grid No.3 resistor        | $R_{g_3}$     | max. 50 k $\Omega$ |
| Cathode to heater voltage | $V_{kf}$      | max. 150 V         |
| D.C. component            |               | max. 100 V         |



## TRIODE-HEPTODE

Triode-heptode intended for use as pulse separator, noise inverter and sync. amplifier.

| QUICK REFERENCE DATA     |               |          |
|--------------------------|---------------|----------|
| <u>Triode section</u>    |               |          |
| Anode voltage            | $V_a$         | 50 V     |
| Anode current            | $I_a$         | 3 mA     |
| Transconductance         | $S$           | 3.7 mA/V |
| Amplification factor     | $\mu$         | 50 -     |
| <u>Heptode section</u>   |               |          |
| Anode voltage            | $V_a$         | 135 V    |
| Grids No.2 and 4 voltage | $V_{g_{2+4}}$ | 14 V     |
| Anode current            | $I_a$         | 1.7 mA   |
| Grids No.2 and 4 current | $I_{g_{2+4}}$ | 0.9 mA   |
| Transconductance         | $S$           | 2.2 mA/V |

**HEATING:** Indirect by A.C. or D.C.; series or parallel supply

Heater voltage

$V_f$  6.3 V

Heater current

$I_f$  300 mA

### DIMENSIONS AND CONNECTIONS

Dimensions in mm

Base: Noval

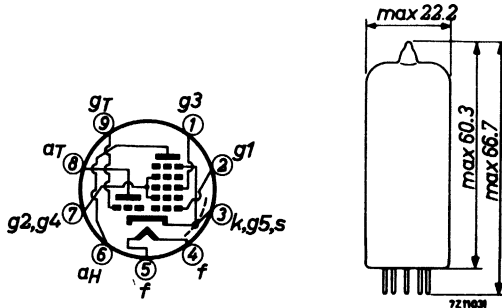

**CAPACITANCES**

Triode section

|                          |            |        |
|--------------------------|------------|--------|
| Grid to all except anode | $C_{g(a)}$ | 3.0 pF |
| Anode to grid            | $C_{ag}$   | 1.1 pF |

Heptode section

|                     |           |               |
|---------------------|-----------|---------------|
| Anode to grid No. 1 | $C_{ag1}$ | max. 0.009 pF |
|---------------------|-----------|---------------|

Between triode and heptode sections

|                                    |             |              |
|------------------------------------|-------------|--------------|
| Grid triode to grid No. 1 heptode  | $C_{gTG1H}$ | max. 0.10 pF |
| Anode triode to grid No. 1 heptode | $C_{aTG1H}$ | max. 0.08 pF |
| Anode triode to grid No. 3 heptode | $C_{aTg3H}$ | max. 0.13 pF |
| Grid triode to anode heptode       | $C_{gTaH}$  | max. 0.09 pF |
| Anode triode to anode heptode      | $C_{aTaH}$  | max. 0.25 pF |

**TYPICAL CHARACTERISTICS**

Triode section

|                      |       |             |
|----------------------|-------|-------------|
| Anode voltage        | $V_a$ | 50 V        |
| Grid voltage         | $V_g$ | 0 V         |
| Anode current        | $I_a$ | 3 mA        |
| Transconductance     | $S$   | 3.7 mA/V    |
| Amplification factor | $\mu$ | 50 -        |
| Anode voltage        | $V_a$ | 200 V       |
| Grid voltage         | $V_g$ | -11 V       |
| Anode current        | $I_a$ | max. 0.1 mA |

**TYPICAL CHARACTERISTICS** (continued)Heptode section

|                           |            |            |
|---------------------------|------------|------------|
| Anode voltage             | $V_a$      | 135 V      |
| Grid No. 3 voltage        | $V_{g3}$   | 0 V        |
| Grids No. 2 and 4 voltage | $V_{g2+4}$ | 14 V       |
| Grid No. 1 voltage        | $V_{g1}$   | 0 V        |
| Anode current             | $I_a$      | 1.7 mA     |
| Grids No. 2 and 4 current | $I_{g2+4}$ | 0.9 mA     |
| Transconductance          | $S$        | 2.2 mA/V   |
| Grid No. 3 voltage        | $V_{g3}$   | -2 V       |
| Grid No. 1 voltage        | $V_{g1}$   | 0 V        |
| Anode current             | $I_a$      | 20 $\mu$ A |
| Grid No. 1 voltage        | $V_{g1}$   | -1.9 V     |
| Grid No. 3 voltage        | $V_{g3}$   | 0 V        |
| Anode current             | $I_a$      | 20 $\mu$ A |

**LIMITING VALUES** (Design centre rating system)Heptode section

|                                   |              |                                       |
|-----------------------------------|--------------|---------------------------------------|
| Anode voltage                     | $V_{a0}$     | max. 550 V                            |
|                                   | $V_a$        | max. 250 V                            |
| Anode dissipation                 | $W_a$        | max. 1.7 W                            |
| Grids No. 2 + 4 voltage           | $V_{g2+4_0}$ | max. 550 V                            |
|                                   | $V_{g2+4}$   | max. 250 V<br>min. 10 V <sup>1)</sup> |
| Grids No. 2 + 4 dissipation       | $W_{g2+4}$   | max. 0.8 W                            |
| Grid No. 3 voltage, negative peak | $-V_{g3p}$   | max. 150 V                            |
| Grid No. 3 resistor               | $R_{g3}$     | max. 3 M $\Omega$                     |
| Grid No. 1 voltage, negative peak | $-V_{g1p}$   | max. 150 V                            |
| Grid No. 1 resistor               | $R_{g1}$     | max. 3 M $\Omega$                     |
| Cathode current                   | $I_k$        | max. 12.5 mA                          |
| Cathode to heater voltage         | $V_{kf}$     | max. 100 V                            |

<sup>1)</sup> This value applies to an average tube operated under the worst probable conditions.

## LIMITING VALUES (continued)

### Triode section

|                             |           |                   |
|-----------------------------|-----------|-------------------|
| Anode voltage               | $V_{a0}$  | max. 550 V        |
|                             | $V_a$     | max. 250 V        |
| Anode dissipation           | $W_a$     | max. 1.3 W        |
| Grid voltage, negative peak | $-V_{gp}$ | max. 200 V        |
| Grid resistor               | $R_g$     | max. 3 M $\Omega$ |
| Cathode current             | $I_k$     | max. 10 mA        |
| Cathode to heater voltage   | $V_{kf}$  | max. 100 V        |

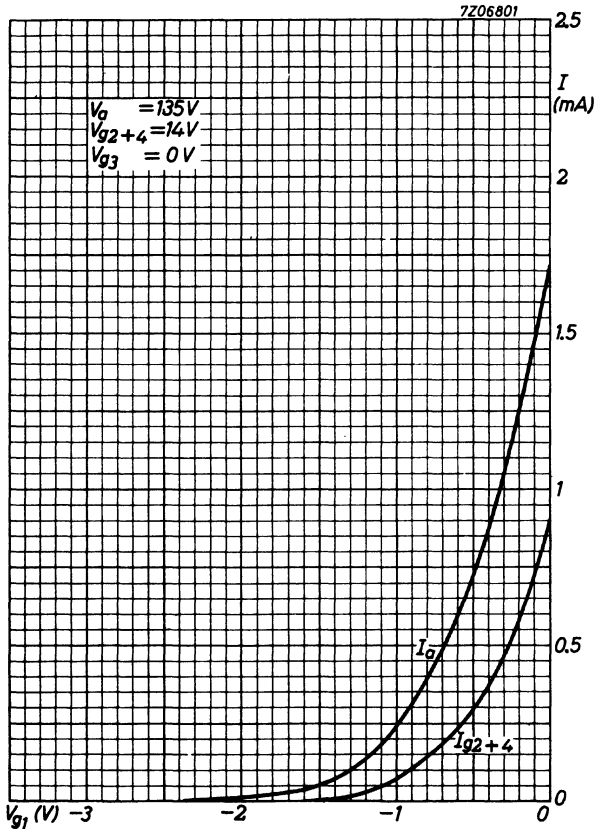

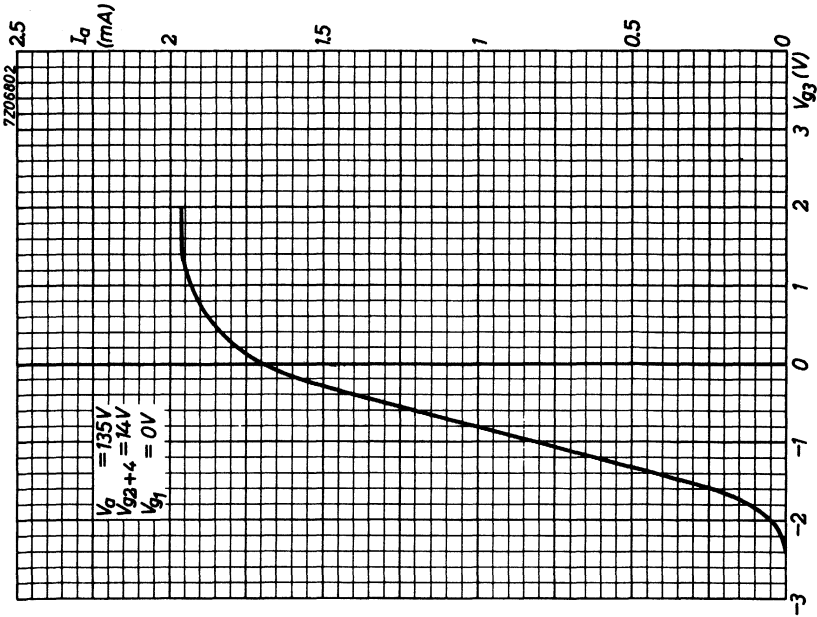
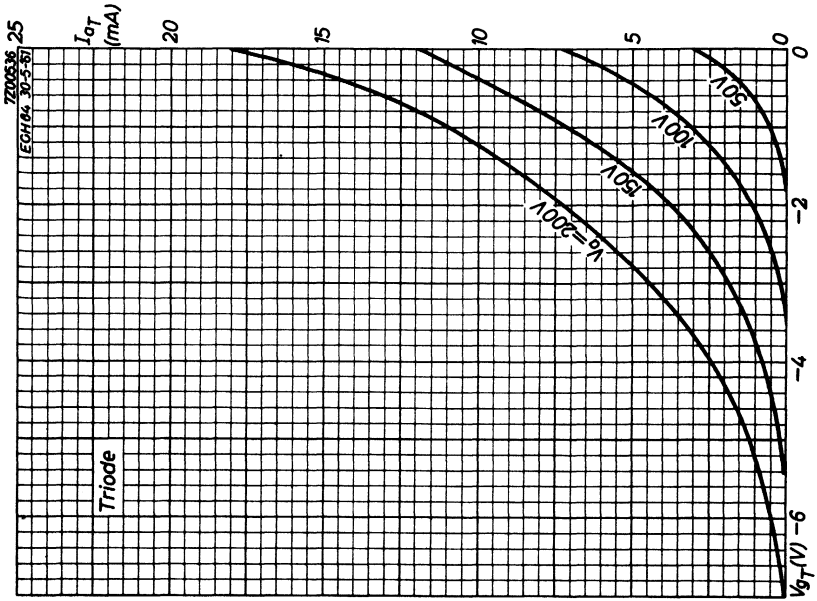

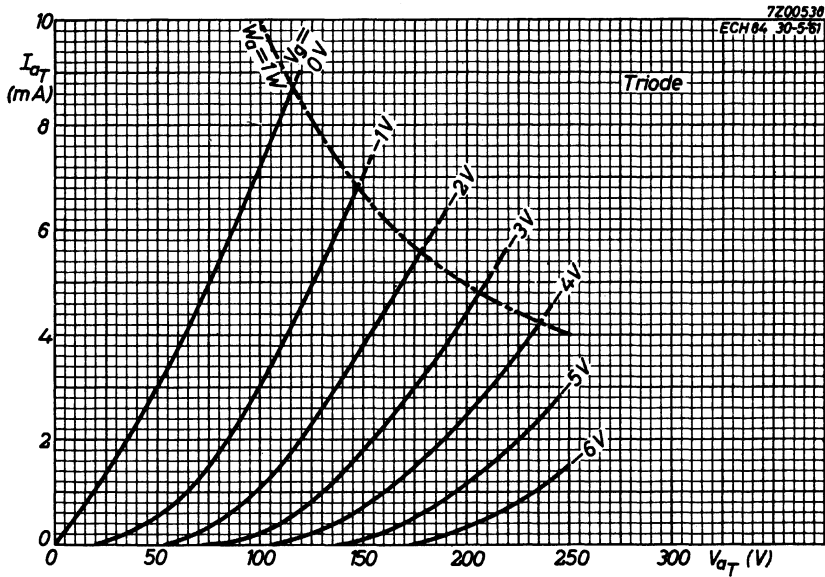

## TRIODE-HEPTODE

Triode-heptode; triode section intended for use as pulse amplifier and heptode section for use as noise gated sync. separator.

**HEATING:** Indirect by A.C. or D.C.; parallel supply

|                |       |            |    |
|----------------|-------|------------|----|
| Heater voltage | $V_f$ | <u>6.3</u> | V  |
| Heater current | $I_f$ | 435        | mA |

**LIMITING VALUES** (Design centre rating system)

Triode section

|                           |          |          |   |
|---------------------------|----------|----------|---|
| Cathode to heater voltage | $V_{kf}$ | max. 100 | V |
|---------------------------|----------|----------|---|

Heptode section

|                           |          |          |   |
|---------------------------|----------|----------|---|
| Cathode to heater voltage | $V_{kf}$ | max. 100 | V |
|---------------------------|----------|----------|---|

-----  
 For further data and curves of this type  
 please refer to type PCH200  
 -----





## TRIODE-OUTPUT PENTODE

The triode section is intended for use as frame oscillator and A.F. amplifier. The pentode section is intended for use as frame output tube and A.F. power amplifier.

| QUICK REFERENCE DATA   |                |          |      |
|------------------------|----------------|----------|------|
| <u>Triode section</u>  |                |          |      |
| Anode current          | $I_a$          | 3.5      | mA   |
| Transconductance       | $S$            | 2.2      | mA/V |
| Amplification factor   | $\mu$          | 70       | -    |
| <u>Pentode section</u> |                |          |      |
| Anode peak voltage     | $V_{ap}$       | max. 2.5 | kV   |
| Anode current          | $I_a$          | 41       | mA   |
| Transconductance       | $S$            | 7.5      | mA/V |
| Amplification factor   | $\mu_{g_2g_1}$ | 9.5      | -    |
| Output power           | $W_o$          | 3.5      | W    |

**HEATING:** Indirect by A.C. or D.C.; parallel supply

|                |       |     |    |
|----------------|-------|-----|----|
| Heater voltage | $V_f$ | 6.3 | V  |
| Heater current | $I_f$ | 780 | mA |

### DIMENSIONS AND CONNECTIONS

Dimensions in mm

Base: Noval

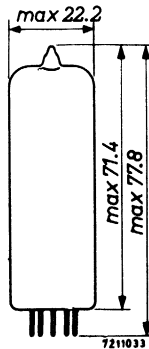
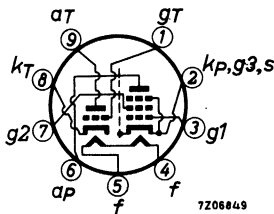

**CAPACITANCES**

Triode section

|                          |            |             |
|--------------------------|------------|-------------|
| Anode to all except grid | $C_{a(g)}$ | 4.3 pF      |
| Grid to all except anode | $C_{g(a)}$ | 2.7 pF      |
| Anode to grid            | $C_{ag}$   | 4.4 pF      |
| Grid to heater           | $C_{gf}$   | max. 0.1 pF |

Pentode section

|                               |              |             |
|-------------------------------|--------------|-------------|
| Anode to all except grid No.1 | $C_{a(g_1)}$ | 8.0 pF      |
| Grid No.1 to all except anode | $C_{g_1(a)}$ | 9.3 pF      |
| Anode to grid No.1            | $C_{ag_1}$   | max. 0.3 pF |
| Grid No.1 to heater           | $C_{g_1f}$   | max. 0.3 pF |

Between triode and pentode sections

|                                   |              |               |
|-----------------------------------|--------------|---------------|
| Anode triode to grid No.1 pentode | $C_{aTg_1P}$ | max. 0.02 pF  |
| Grid triode to anode pentode      | $C_{gTaP}$   | max. 0.02 pF  |
| Grid triode to grid No.1 pentode  | $C_{gTg_1P}$ | max. 0.025 pF |
| Anode triode to anode pentode     | $C_{aTaP}$   | max. 0.25 pF  |

**TYPICAL CHARACTERISTICS**

Triode section

|                      |       |          |
|----------------------|-------|----------|
| Anode voltage        | $V_a$ | 100 V    |
| Grid voltage         | $V_g$ | 0 V      |
| Anode current        | $I_a$ | 3.5 mA   |
| Transconductance     | $S$   | 2.2 mA/V |
| Amplification factor | $\mu$ | 70 -     |

Pentode section

|                      |                |               |
|----------------------|----------------|---------------|
| Anode voltage        | $V_a$          | 170 V         |
| Grid No.2 voltage    | $V_{g_2}$      | 170 V         |
| Grid No.1 voltage    | $V_{g_1}$      | -11.5 V       |
| Anode current        | $I_a$          | 41 mA         |
| Grid No.2 current    | $I_{g_2}$      | 9 mA          |
| Transconductance     | $S$            | 7.5 mA/V      |
| Amplification factor | $\mu_{g_2g_1}$ | 9.5 -         |
| Internal resistance  | $R_i$          | 16 k $\Omega$ |

## OPERATING CHARACTERISTICS

Triode section as A.F. amplifier

|                             |                         |      |           |           |
|-----------------------------|-------------------------|------|-----------|-----------|
| A. Signal source resistance | $R_s$                   | 0.22 | $M\Omega$ |           |
| Grid resistor               | $R_g$                   | 3    | $M\Omega$ |           |
| Grid resistor of next stage | $R_g$                   | 0.68 | $M\Omega$ |           |
| Supply voltage              | $V_b$                   | 200  | 170       | V         |
| Cathode resistor            | $R_k$                   | 2.2  | 2.7       | $k\Omega$ |
| Anode resistor              | $R_a$                   | 220  | 220       | $k\Omega$ |
| Anode current               | $I_a$                   | 0.52 | 0.43      | mA        |
| Voltage gain                | $V_o/V_i$ <sup>1)</sup> | 52   | 51        | -         |
| Max. output voltage         | $V_o$ max               | 26   | 25        | $V_{RMS}$ |
| Distortion                  | $d_{tot}$ <sup>2)</sup> | 1.6  | 2.3       | %         |

|                             |                         |      |      |      |      |           |
|-----------------------------|-------------------------|------|------|------|------|-----------|
| B. Signal source resistance | $R_s$                   | 0.22 |      |      |      | $M\Omega$ |
| Grid resistor               | $R_g$                   | 22   |      |      |      | $M\Omega$ |
| Grid resistor of next stage | $R_g'$                  | 0.68 |      |      |      | $M\Omega$ |
| Supply voltage              | $V_b$                   | 200  | 200  | 170  | 170  | V         |
| Cathode resistor            | $R_k$                   | 0    | 0    | 0    | 0    | $\Omega$  |
| Anode resistor              | $R_a$                   | 100  | 220  | 100  | 220  | $k\Omega$ |
| Anode current               | $I_a$                   | 1.05 | 0.61 | 0.86 | 0.50 | $M\Omega$ |
| Voltage gain                | $V_o/V_i$ <sup>1)</sup> | 50   | 55   | 49   | 53   | -         |
| Max. output voltage         | $V_o$ max               | 24   | 25   | 19   | 20   | $V_{RMS}$ |
| Distortion                  | $d_{tot}$ <sup>3)</sup> | 1.5  | 1.4  | 1.4  | 1.4  | %         |

## MICROPHONY AND HUM

The triode section can be used without special precautions against microphony and hum in circuits in which an input voltage of minimum 10 mVRMS is required for an output of 50 mW of the output stage.  $Z_g(50 \text{ Hz}) = 0.25 M\Omega$ .

1) Measured at small input voltage.

2) At lower output voltages the distortion is proportionally lower.

3) At lower output voltages down to 5 VRMS the distortion is approximately constant. At values below 5 VRMS the distortion is approximately proportional to  $V_o$ .

**OPERATING CHARACTERISTICS**

Pentode section

A.F. power amplifier, class A (measured with  $V_k$  constant)

|  |                    |              |            |            |
|--|--------------------|--------------|------------|------------|
| Supply voltage                               | $V_{ba} = V_{bg2}$ | 200          | 272        | V          |
| Grid No.2 series resistor<br>(non-decoupled) | $R_{g2}$           | 470          | 2200       | $\Omega$   |
| Cathode resistor                             | $R_k$              | 330          | 650        | $\Omega$   |
| Load resistance                              | $R_{a\sim}$        | 4.5          | 8          | k $\Omega$ |
| Grid No.1 driving voltage                    | $V_i$              | 0 0.66 6.7   | 0 0.9 9.5  | $V_{RMS}$  |
| Anode current                                | $I_a$              | 35 37 28     | 27         | mA         |
| Grid No.2 current                            | $I_{g2}$           | 7.8 13.3 6.5 | 10.8       | mA         |
| Output power                                 | $W_o$              | 0 0.05 3.3   | 0 0.05 3.5 | W          |
| Distortion                                   | $d_{tot}$          | - - 10       | - - 10     | %          |

A.F. power amplifier, class AB, two tubes in push-pull

|                           |               |             |            |            |
|---------------------------|---------------|-------------|------------|------------|
| Anode supply voltage      | $V_{ba}$      | 200         | 250        | V          |
| Grid No.2 supply voltage  | $V_{bg2}$     | 200         | 200        | V          |
| Common cathode resistor   | $R_k$         | 170         | 220        | $\Omega$   |
| Load resistance           | $R_{aa'\sim}$ | 4.5         | 10         | k $\Omega$ |
| Grid No.1 driving voltage | $V_i$         | 0 14.2      | 0 12.5     | $V_{RMS}$  |
| Anode current             | $I_a$         | 2x35 2x42.5 | 2x28 2x31  | mA         |
| Grid No.2 current         | $I_{g2}$      | 2x8 2x16.5  | 2x5.8 2x13 | mA         |
| Output power              | $W_o$         | 0 9.3       | 0 10.5     | W          |
| Distortion                | $d_{tot}$     | - 6.3       | - 4.8      | %          |

Frame output application

The circuit should operate satisfactorily with a peak anode current  $I_{ap} = 85$  mA at  $V_a = 50$  V,  $V_{g2} = 170$  V,  $V_f = 6.3$  V. The minimum available  $I_{ap}$  at end of life is;

- 70 mA at  $V_a = 50$  V,  $V_{g2} = 170$  V,  $V_f = 5.5$  V
- 80 mA at  $V_a = 50$  V,  $V_{g2} = 190$  V,  $V_f = 5.5$  V.





**TRIODE-OUTPUT PENTODE**

Triode-pentode with separate cathodes

The triode section is intended for use in circuits for keyed AGC, sync separation, sync amplification and noise suppression.

The pentode section is intended for use as video output tube.

**HEATING:** Indirect by A. C. or D. C.; parallel supply

Heater voltage

$V_f$  6.3 V

Heater current

$I_f$  720 mA

**LIMITING VALUES** (Design centre rating system)

Triode section

Cathode to heater voltage

$V_{kf}$  max. 200 V

-----  
For further data and curves  
please refer to PCL84  
-----





## TRIODE-OUTPUT PENTODE

Triode pentode with separate cathodes.

Triode intended for use as frame oscillator or pulse amplifier.

Pentode intended for use as frame output tube.

**HEATING:** Indirect by A. C. or D. C.; parallel supply

|                |       |        |
|----------------|-------|--------|
| Heater voltage | $V_f$ | 6.3 V  |
| Heater current | $I_f$ | 875 mA |

### OPERATING CHARACTERISTICS OF THE PENTODE SECTION

#### Hum

The equivalent pentode grid hum voltage without negative feedback and without A. C. voltage between heater and cathode is max. 10 mVRMS when  $Z_{g_1}$  (at  $f = 50$  Hz)  $\leq 0.5$  M $\Omega$  and  $C_{g_1-f} = 0.2$  pF.

### **LIMITING VALUES** (Design centre rating system)

#### Triode section

|                                   |                  |            |
|-----------------------------------|------------------|------------|
| Cathode to heater voltage         | $V_{kf}$         | max. 100 V |
| D. C. component during warming up | $V_{kf}$ (k pos) | max. 315 V |

#### Pentode section

|                           |          |            |
|---------------------------|----------|------------|
| Cathode to heater voltage | $V_{kf}$ | max. 100 V |
|---------------------------|----------|------------|

-----  
For further data and curves  
please refer to PCL85/PCL805  
-----



## TRIODE-OUTPUT PENTODE

Triode pentode with separate cathodes.

The triode section is intended for use as A.F. amplifier.

The pentode section is intended for use as A.F. power amplifier.

| QUICK REFERENCE DATA   |                |          |
|------------------------|----------------|----------|
| <u>Triode section</u>  |                |          |
| Anode current          | $I_a$          | 1.2 mA   |
| Transconductance       | S              | 1.6 mA/V |
| Amplification factor   | $\mu$          | 100 -    |
| <u>Pentode section</u> |                |          |
| Anode current          | $I_a$          | 36 mA    |
| Transconductance       | S              | 10 mA/V  |
| Amplification factor   | $\mu_{g_2g_1}$ | 21 -     |
| Output power           | $W_o$          | 4.0 W    |

**HEATING:** Indirect by A.C. or D.C.; parallel supply

Heater voltage

$V_f$  6.3 V

Heater current

$I_f$  660 mA

### DIMENSIONS AND CONNECTIONS

Dimensions in mm

Base: Noval

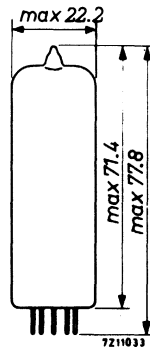
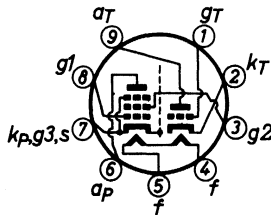

**CAPACITANCES**

Triode section

|                          |            |               |
|--------------------------|------------|---------------|
| Anode to all except grid | $C_{a(g)}$ | 2.5 pF        |
| Grid to all except anode | $C_{g(a)}$ | 2.3 pF        |
| Anode to grid            | $C_{ag}$   | 1.4 pF        |
| Grid to heater           | $C_{gf}$   | max. 0.006 pF |

Pentode section

|                               |              |              |
|-------------------------------|--------------|--------------|
| Grid No.1 to all except anode | $C_{g_1(a)}$ | 10 pF        |
| Anode to grid No.1            | $C_{ag_1}$   | max. 0.4 pF  |
| Grid No.1 to heater           | $C_{g_1f}$   | max. 0.24 pF |

Between triode and pentode sections

|                                   |              |                             |
|-----------------------------------|--------------|-----------------------------|
| Anode triode to grid No.1 pentode | $C_{aTg_1P}$ | max. 0.2 pF                 |
| Grid triode to grid No.1 pentode  | $C_{gTg_1P}$ | max. 0.02 pF                |
| Anode triode to anode pentode     | $C_{aTaP}$   | max. 0.15 pF                |
| Grid triode to anode pentode      | $C_{gTaP}$   | max. 0.006 pF <sup>1)</sup> |

**TYPICAL CHARACTERISTICS**

Triode section

|                      |       |          |
|----------------------|-------|----------|
| Anode voltage        | $V_a$ | 250 V    |
| Grid voltage         | $V_g$ | -1.9 V   |
| Anode current        | $I_a$ | 1.2 mA   |
| Transconductance     | $S$   | 1.6 mA/V |
| Amplification factor | $\mu$ | 100 -    |

Pentode section

|                      |                |               |
|----------------------|----------------|---------------|
| Anode voltage        | $V_a$          | 250 V         |
| Grid No.2 voltage    | $V_{g_2}$      | 250 V         |
| Grid No.1 voltage    | $V_{g_1}$      | -7 V          |
| Anode current        | $I_a$          | 36 mA         |
| Grid No.2 current    | $I_{g_2}$      | 6 mA          |
| Transconductance     | $S$            | 10 mA/V       |
| Amplification factor | $\mu_{g_2g_1}$ | 21 -          |
| Internal resistance  | $R_i$          | 48 k $\Omega$ |

<sup>1)</sup> The capacitance between triode grid and pentode anode ( $C_{gT-aP}$ ) can be reduced to a value of less than 0.002 pF by using a shielding ring with a diameter of 22.5 mm and a height of 15 mm with respect to the tube base.

**OPERATING CHARACTERISTICS**Triode sectionas A.F. amplifier

|                                  |           |      |      |      |     |           |
|----------------------------------|-----------|------|------|------|-----|-----------|
| Supply voltage                   | $V_b$     | 200  | 250  | 250  | 300 | V         |
| Cathode resistor                 | $R_k$     | 2.6  | 1.75 | 1.75 | 1.2 | $k\Omega$ |
| Anode resistor                   | $R_a$     | 220  | 220  | 220  | 220 | $k\Omega$ |
| Grid resistor of following stage | $R_{g'}$  | 0.68 | 0.68 | 10   | 10  | $M\Omega$ |
| Anode current                    | $I_a$     | 0.42 | 0.6  | 0.6  | 0.8 | mA        |
| Output voltage                   | $V_o$     | 3.2  | 3.2  | 5    | 9   | $V_{RMS}$ |
| Voltage gain                     | $V_o/V_i$ | 66   | 70   | 75   | 80  | -         |
| Distortion                       | $d_{tot}$ | 0.6  | 0.4  | 0.4  | 0.4 | %         |

A.F. amplifier with grid current biasing

|                                  |           |      |      |     |     |           |
|----------------------------------|-----------|------|------|-----|-----|-----------|
| Supply voltage                   | $V_b$     | 200  | 250  | 250 | 300 | V         |
| Cathode resistor                 | $R_k$     | 0    | 0    | 0   | 0   | $\Omega$  |
| Anode resistor                   | $R_a$     | 220  | 220  | 220 | 220 | $k\Omega$ |
| Grid resistor                    | $R_g$     | 10   | 10   | 10  | 10  | $M\Omega$ |
| Grid resistor of following stage | $R_{g'}$  | 0.68 | 0.68 | 10  | 10  | $M\Omega$ |
| Signal source resistance         | $R_s$     | 47   | 47   | 47  | 47  | $k\Omega$ |
| Anode current                    | $I_a$     | 0.42 | 0.6  | 0.6 | 0.8 | mA        |
| Output voltage                   | $V_o$     | 3.2  | 3.2  | 5   | 9   | $V_{RMS}$ |
| Voltage gain                     | $V_o/V_i$ | 66   | 70   | 75  | 80  | -         |
| Distortion                       | $d_{tot}$ | 0.6  | 0.4  | 0.4 | 0.4 | %         |

**MICROPHONY**

The triode section can be used without special precautions against microphonic effect in circuits in which an output of 50 mW is obtained at an input voltage of not less than 4 mV<sub>RMS</sub>.

**HUM**

The hum level will be better than 60 dB under the following conditions:

Input voltage minimum 10 mV<sub>RMS</sub> for 50 mW output.

Grid circuit impedance max. 0.5 M $\Omega$  at 50 Hz.

Cathode decoupling capacitor minimum 100  $\mu$ F.

Pin 4 connected to earth.

**OPERATING CHARACTERISTICS (continued)**

Pentode section

Class A (Measured with  $V_k$  constant)

|                           |             |            |  |            |           |
|---------------------------|-------------|------------|--|------------|-----------|
| Anode voltage             | $V_a$       | 250        |  | 250        | V         |
| Grid No.2 voltage         | $V_{g2}$    | 250        |  | 250        | V         |
| Cathode resistor          | $R_k$       | 170        |  | 270        | $\Omega$  |
| Load resistance           | $R_{a\sim}$ | 7          |  | 10         | $k\Omega$ |
| Grid No.1 driving voltage | $V_i$       | 0 0.3 3.2  |  | 0 0.28 2.7 | $V_{RMS}$ |
| Anode current             | $I_a$       | 36 - 37    |  | 26 - 27    | mA        |
| Grid No.2 current         | $I_{g2}$    | 6 - 10.2   |  | 4.4 - 8.0  | mA        |
| Output power              | $W_o$       | 0 0.05 4.0 |  | 0 0.05 2.8 | W         |
| Distortion                | $d_{tot}$   | - 0.95 10  |  | - 1.1 10   | %         |

Class AB, two tubes in push-pull

|                           |              |                 |  |               |           |
|---------------------------|--------------|-----------------|--|---------------|-----------|
| Supply voltage            | $V_b$        | 250             |  | 300           | V         |
| Common cathode resistor   | $R_k$        | 90              |  | 130           | $\Omega$  |
| Load resistance           | $R_{aa\sim}$ | 8.2             |  | 9.1           | $k\Omega$ |
| Grid No.1 driving voltage | $V_i$        | 0 0.24 5.5      |  | 0 0.26 8.4    | $V_{RMS}$ |
| Anode current             | $I_a$        | 2x32.5 - 2x35.5 |  | 2x31 - 2x36.5 | mA        |
| Grid No.2 current         | $I_{g2}$     | 2x5.6 - 2x8.9   |  | 2x5.5 - 2x11  | mA        |
| Output power              | $W_o$        | 0 0.05 10       |  | 0 0.05 13.6   | W         |
| Distortion                | $d_{tot}$    | - <0.4 5.0      |  | - <0.4 4.0    | %         |

**LIMITING VALUES** (Design centre rating system)Triode section

|                           |          |                                |
|---------------------------|----------|--------------------------------|
| Anode voltage             | $V_{a0}$ | max. 550 V                     |
|                           | $V_a$    | max. 300 V                     |
| Anode dissipation         | $W_a$    | max. 0.5 W                     |
| Cathode current           | $I_k$    | max. 4 mA                      |
| Grid resistor             | $R_g$    | max. 1 $M\Omega$ <sup>1)</sup> |
| Cathode to heater voltage | $V_{kf}$ | max. 100 V                     |

Pentode section

|                           |           |                                  |
|---------------------------|-----------|----------------------------------|
| Anode voltage             | $V_{a0}$  | max. 550 V                       |
|                           | $V_a$     | max. 300 V                       |
| Grid No.2 voltage         | $V_{g20}$ | max. 550 V                       |
|                           | $V_{g2}$  | max. 300 V                       |
| Anode dissipation         | $W_a$     | max. 9 W                         |
| Grid No.2 dissipation     | $W_{g2}$  | average max. 1.8 W               |
|                           |           | peak max. 3.25 W                 |
| Cathode current           | $I_k$     | max. 55 mA                       |
| Grid No.1 resistor        | $R_{g1}$  | max. 0.5 $M\Omega$ <sup>1)</sup> |
| Cathode to heater voltage | $V_{kf}$  | max. 100 V                       |

<sup>1)</sup> This value applies to operation with fixed bias. It may be multiplied by the D.C. inverse feedback factor resulting from e.g. cathode, screen grid or anode resistors, to a maximum of 10  $M\Omega$ .

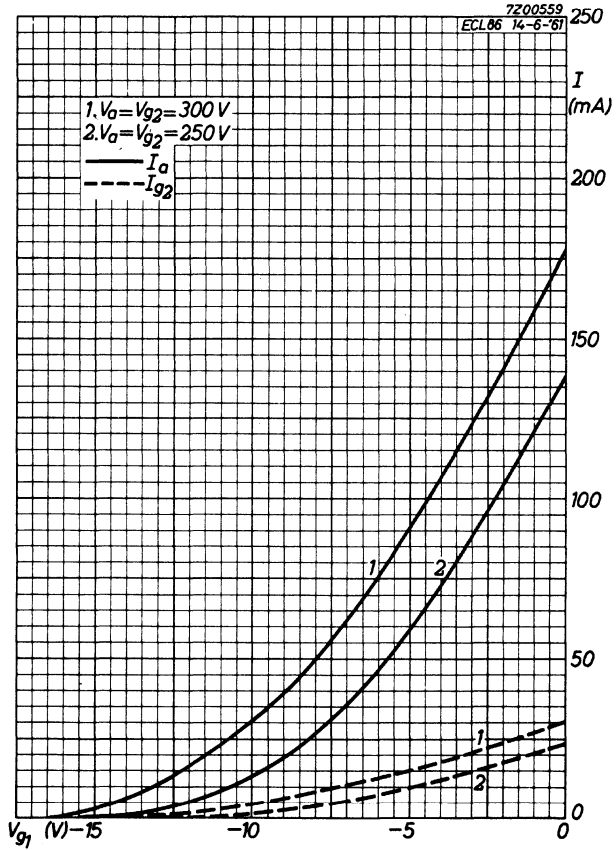



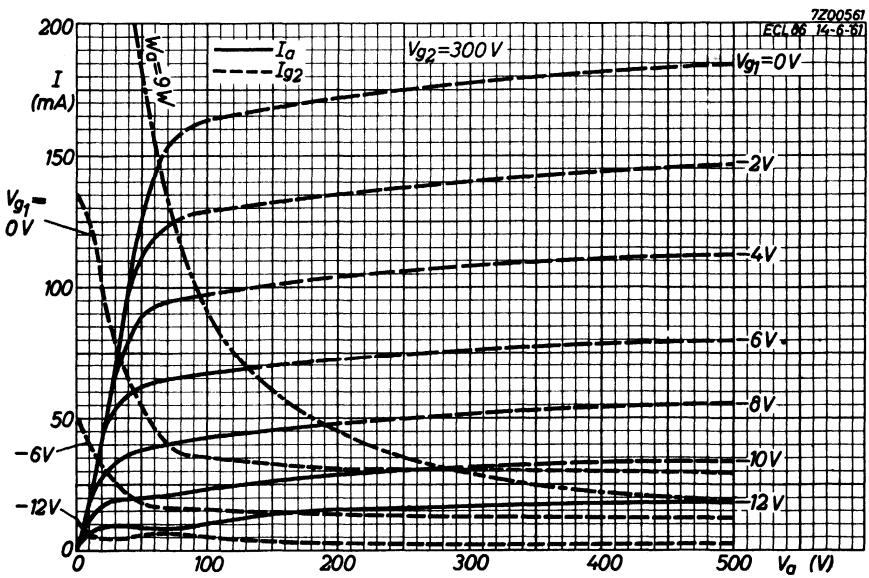
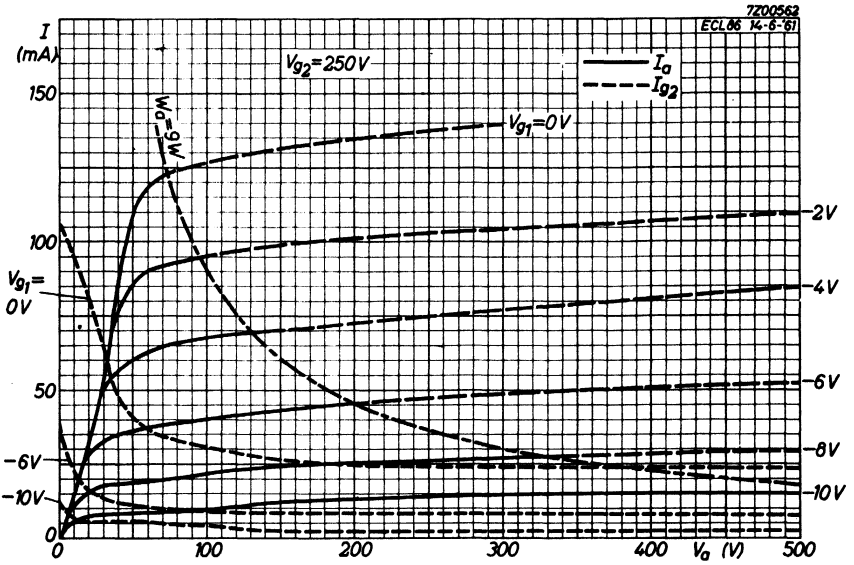

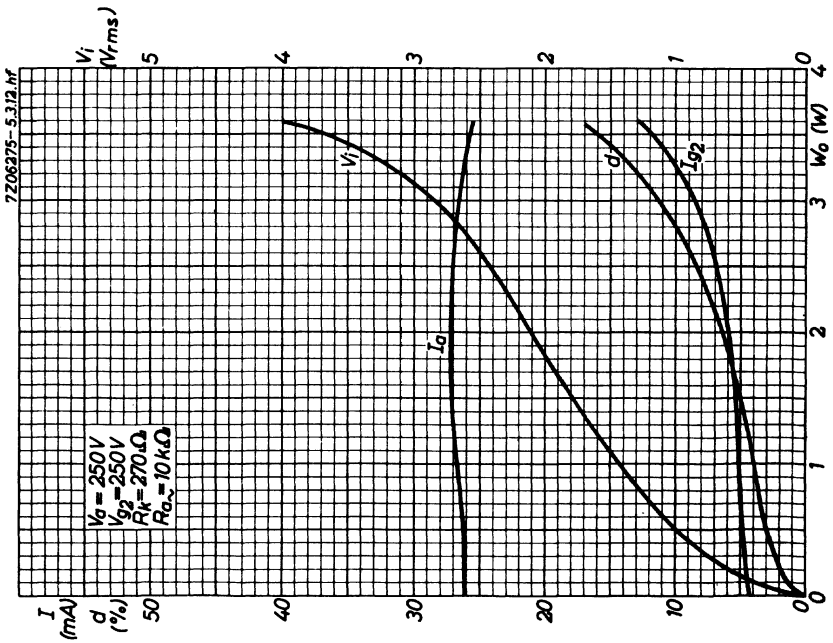
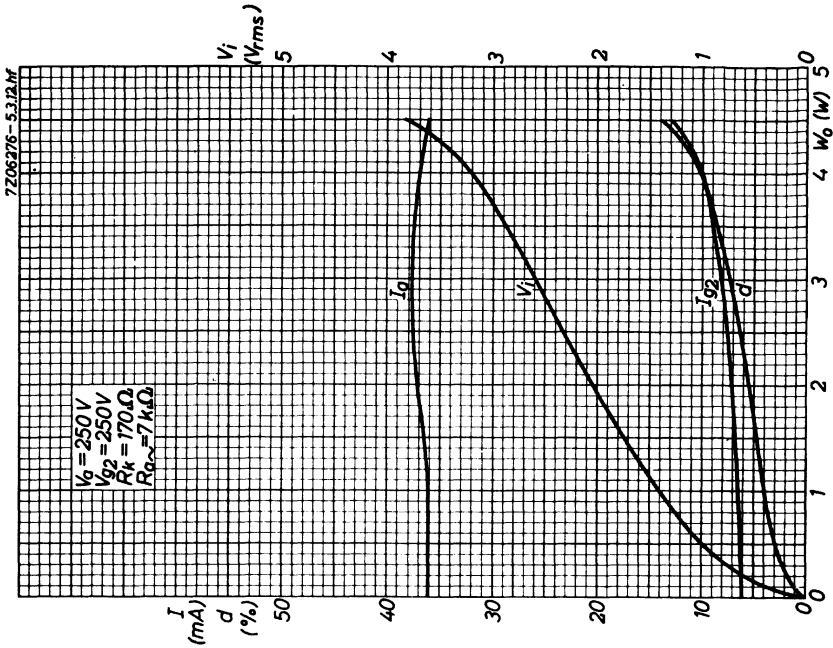

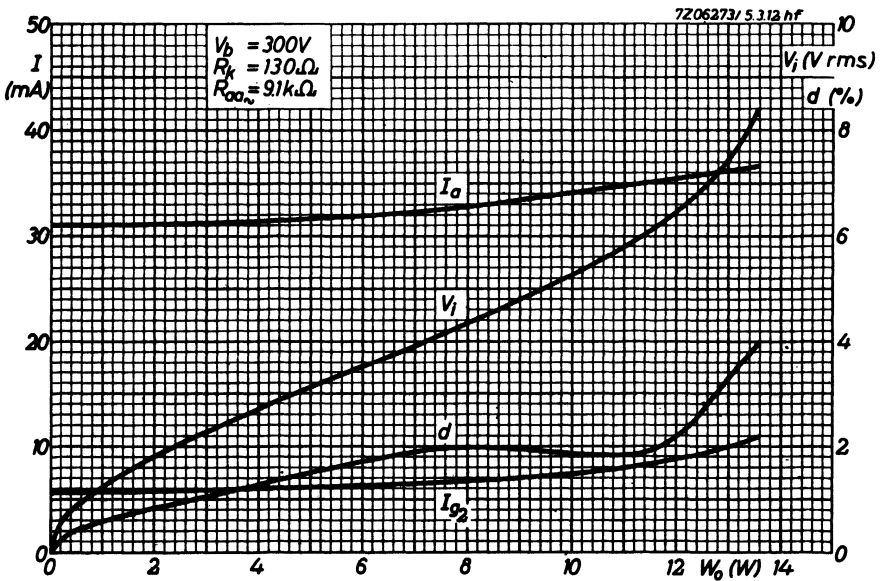
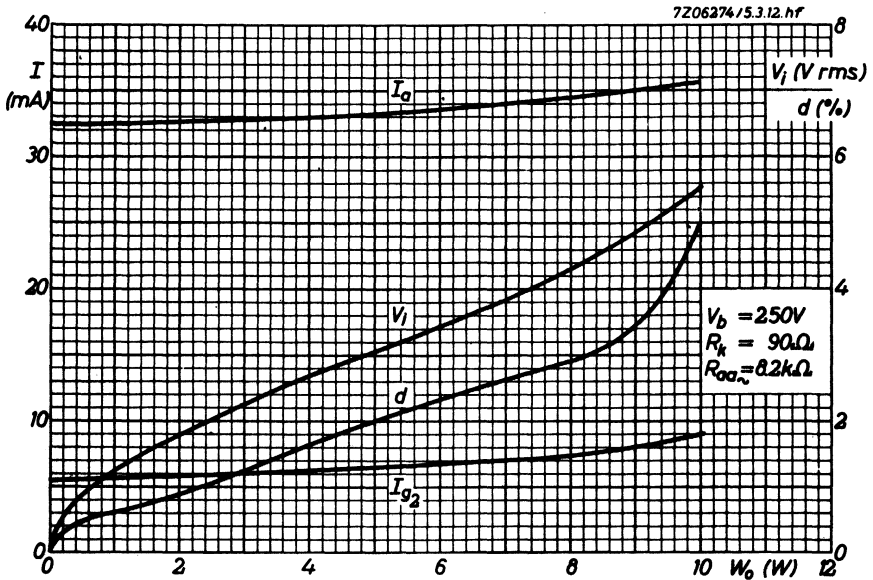

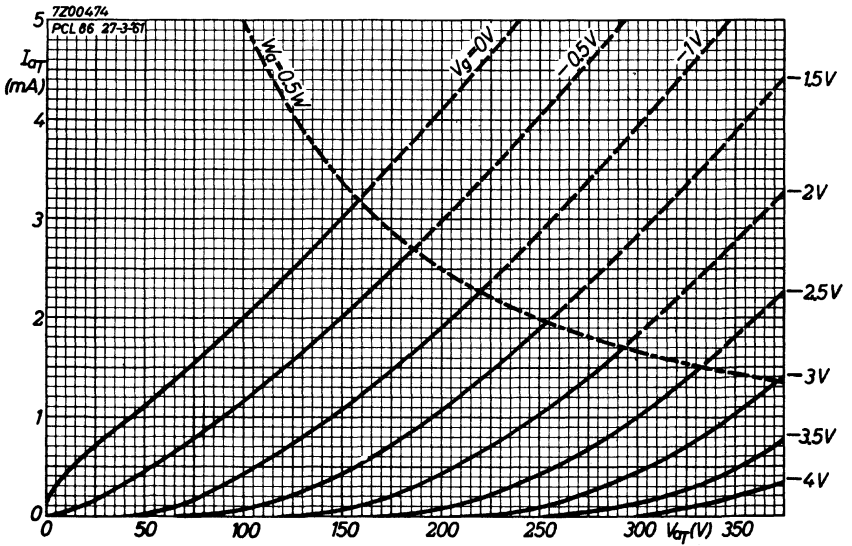
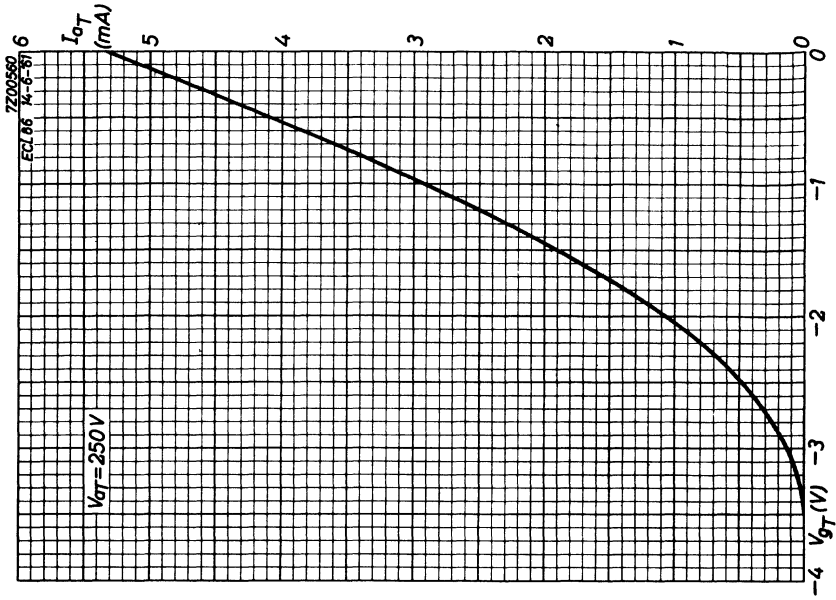

## SHUNT STABILIZER TRIODE

Shunt stabilizer triode intended for use as in colour TV receivers.

**HEATING:** Indirect by A. C. or D. C.; parallel supply

Heater voltage

$V_f$  6.3 V

Heater current

$I_f$  350 mA

-----  
For further data and curve of this type  
please refer to type PD500  
-----



## R.F. PENTODE

Pentode intended for use as R.F., I.F. or video amplifying tube or as mixing tube in television receivers.

| QUICK REFERENCE DATA |                |                |
|----------------------|----------------|----------------|
| Anode current        | $I_a$          | 10 mA          |
| Transconductance     | S              | 7.4 mA/V       |
| Amplification factor | $\mu_{g_2g_1}$ | 50 -           |
| Internal resistance  | $R_i$          | 500 k $\Omega$ |

**HEATING:** Indirect by A.C. or D.C.; series or parallel supply

Heater voltage  $V_f$  6.3 V

Heater current  $I_f$  300 mA

### DIMENSIONS AND CONNECTIONS

Dimensions in mm

Base: Noval

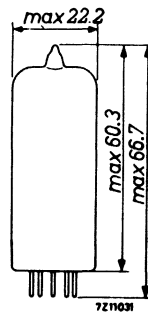
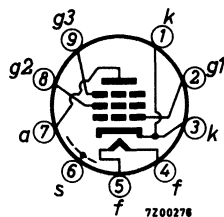

## CAPACITANCES

|                               |             |               |
|-------------------------------|-------------|---------------|
| Grid No.1 to all except anode | $C_{g1(a)}$ | 6.9 pF        |
| Anode to all except grid No.1 | $C_{a(g1)}$ | 3.1 pF        |
| Anode to grid No.1            | $C_{ag1}$   | max. 0.007 pF |
| Anode to cathode              | $C_{ak}$    | max. 0.012 pF |
| Grid No.2 to all              | $C_{g2}$    | 5.4 pF        |
| Grid No.1 to grid No.2        | $C_{g1g2}$  | 2.6 pF        |
| Grid No.1 to heater           | $C_{g1f}$   | max. 0.15 pF  |
| Cathode to heater             | $C_{kf}$    | 5.0 pF        |

## REMARK

When using the EF80 as video amplifier the amplification between the input grid of the EF80 and the input of the cathode ray tube should not exceed a value of 25, in order to prevent microphonic effect.

## TYPICAL CHARACTERISTICS AND OPERATING CHARACTERISTICS

|                                      |              |      |       |      |      |
|--------------------------------------|--------------|------|-------|------|------|
| Anode voltage                        | $V_a$        | 170  | 200   | 250  | V    |
| Grid No.3 voltage                    | $V_{g3}$     | 0    | 0     | 0    | V    |
| Grid No.2 voltage                    | $V_{g2}$     | 170  | 200   | 250  | V    |
| Grid No.1 voltage                    | $V_{g1}$     | -2.0 | -2.55 | -3.5 | V    |
| Anode current                        | $I_a$        | 10   | 10    | 10   | mA   |
| Grid No.2 current                    | $I_{g2}$     | 2.5  | 2.6   | 2.8  | mA   |
| Transconductance                     | S            | 7.4  | 7.1   | 6.8  | mA/V |
| Internal resistance                  | $R_i$        | 0.5  | 0.55  | 0.65 | MΩ   |
| Amplification factor                 | $\mu_{g2g1}$ | 50   | 50    | 50   | -    |
| Equivalent noise resistance          | $R_{eq}$     | 1000 | 1100  | 1200 | Ω    |
| Grid No.1 input resistance           |              |      |       |      |      |
| f = 50 MHz, pin 1 connected to pin 3 | $r_{g1}$     | 10   | 12    | 15   | kΩ   |



**LIMITING VALUES** (Design centre rating system)

|  |               |                   |
|--|---------------|-------------------|
| Anode voltage                          | $V_{a_0}$     | max. 550 V        |
|  | $V_a$         | max. 300 V        |
| Anode dissipation                      | $W_a$         | max. 2.5 W        |
| Grid No.2 voltage                      | $V_{g_{2_0}}$ | max. 550 V        |
|  | $V_{g_2}$     | max. 300 V        |
| Grid No.2 dissipation                  | $W_{g_2}$     | max. 0.7 W        |
| Grid No.2 dissipation ( $W_a < 1.8$ W) | $W_{g_2}$     | max. 0.9 W        |
| Grid No.1 resistor                     | $R_{g_1}$     | max. 1 M $\Omega$ |
| Cathode current                        | $I_k$         | max. 15 mA        |
| Heater to cathode voltage              | $V_{kf}$      | max. 150 V        |

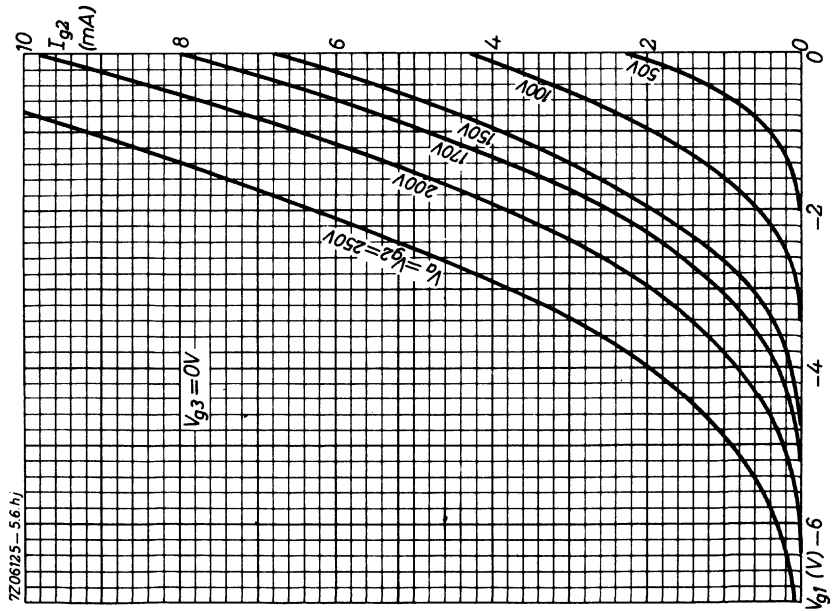
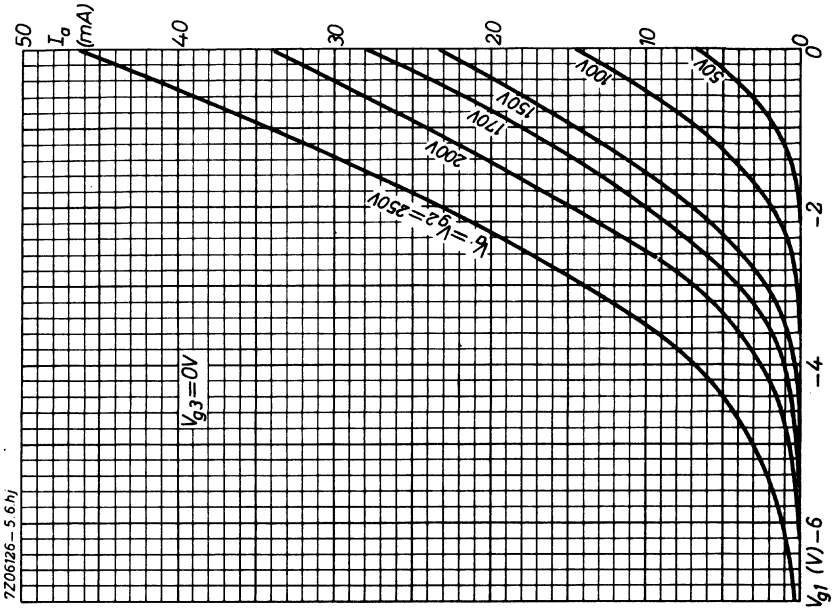

**R.F. PENTODE**

R.F. pentode with variable transconductance intended for use as wide-band amplifier.

| QUICK REFERENCE DATA |                |               |
|----------------------|----------------|---------------|
| Anode current        | $I_a$          | 10 mA         |
| Transconductance     | $S$            | 6.0 mA/V      |
| Amplification factor | $\mu_{g_2g_1}$ | 26 -          |
| Internal resistance  | $R_i$          | 600 $k\Omega$ |

**HEATING** : Indirect by A.C. or D.C. ; series or parallel supply

|                |       |        |
|----------------|-------|--------|
| Heater voltage | $V_f$ | 6.3 V  |
| Heater current | $I_f$ | 300 mA |

**DIMENSIONS AND CONNECTIONS**

Dimensions in mm

Base: Noval

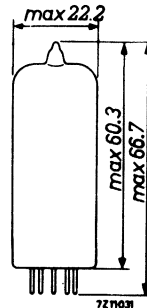
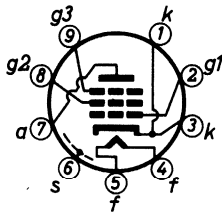

**CAPACITANCES**

|                                |              |               |
|--------------------------------|--------------|---------------|
| Anode to all except grid No. 1 | $C_a(g_1)$   | 3.2 pF        |
| Grid No. 1 to all except anode | $C_{g_1(a)}$ | 6.9 pF        |
| Anode to grid No. 1            | $C_{ag_1}$   | max. 0.007 pF |
| Grid No. 1 to heater           | $C_{g_1f}$   | max. 0.15 pF  |

**TYPICAL CHARACTERISTICS AND OPERATING CHARACTERISTICS**

|   |              |     |              |
|---|--------------|-----|--------------|
| Anode and supply voltage                  | $V_a = V_b$  | 250 | V            |
| Grid No. 3 voltage                        | $V_{g3}$     | 0   | V            |
| Grid No. 2 resistor                       | $R_{g2}$     | 60  | $k\Omega$    |
| Grid No. 1 voltage                        | $V_{g1}$     | -2  | -35 V        |
| Grid No. 2 voltage                        | $V_{g2}$     | 100 | - V          |
| Anode current                             | $I_a$        | 10  | - mA         |
| Grid No. 2 current                        | $I_{g2}$     | 2.5 | - mA         |
| Transconductance                          | S            | 6.0 | 0.06 mA/V    |
| Internal resistance                       | $R_i$        | 0.6 | >5 $M\Omega$ |
| Amplification factor                      | $\mu_{g2g1}$ | 26  | -            |
| Equivalent noise resistance               | $R_{eq}$     | 1.4 | - $k\Omega$  |
| Grid No. 1 input resistance, $f = 50$ MHz | $r_{g1}$     | 9   | - $k\Omega$  |

**LIMITING VALUES** (Design centre rating system)

|                           |           |           |           |
|---------------------------|-----------|-----------|-----------|
| Anode voltage             | $V_{a0}$  | max. 550  | V         |
|                           | $V_a$     | max. 250  | V         |
| Anode dissipation         | $W_a$     | max. 2.5  | W         |
| Grid No. 2 voltage        | $V_{g20}$ | max. 550  | V         |
|                           | $V_{g2}$  | max. 250  | V         |
| Grid No. 2 dissipation    | $W_{g2}$  | max. 0.65 | W         |
| Grid No. 1 resistor       | $R_{g1}$  | max. 3    | $M\Omega$ |
| Cathode current           | $I_k$     | max. 15   | mA        |
| Heater to cathode voltage | $V_{kf}$  | max. 150  | V         |

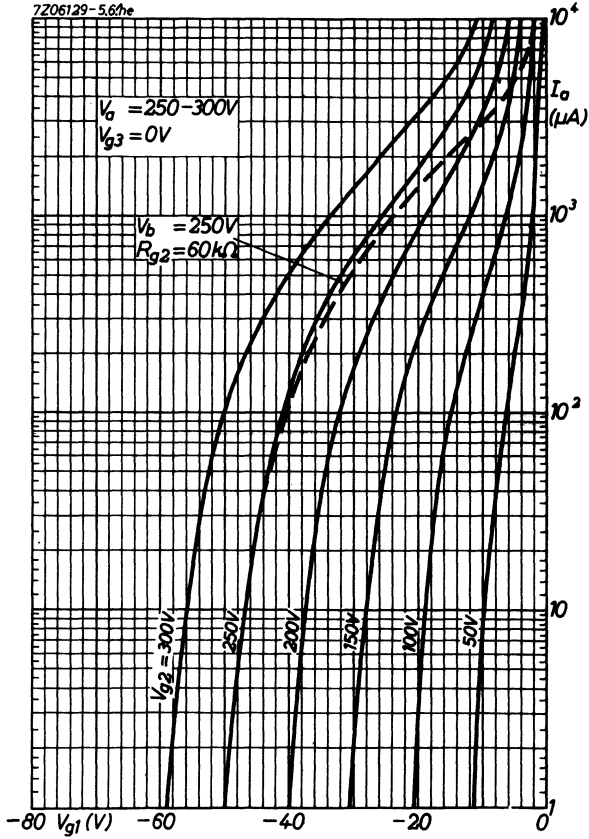

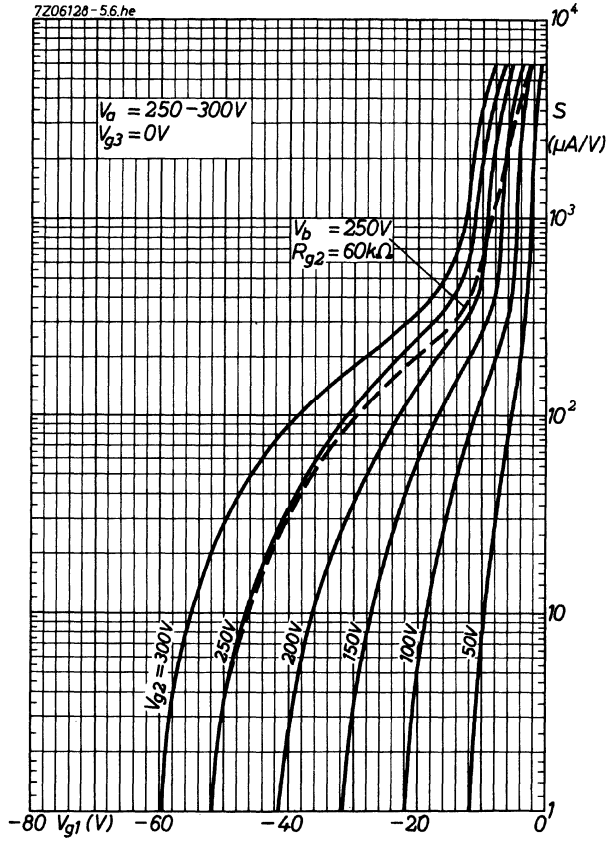

## A.F. PENTODE

Pentode intended for use as A.F. amplifier

| QUICK REFERENCE DATA |                |                |
|----------------------|----------------|----------------|
| Anode current        | $I_a$          | 3.0 mA         |
| Transconductance     | $S$            | 2.2 mA/V       |
| Amplification factor | $\mu_{g_2g_1}$ | 38 -           |
| Internal resistance  | $R_i$          | 2.5 M $\Omega$ |

**HEATING:** Indirect by A.C. or D.C.; series or parallel supply

|                |       |        |
|----------------|-------|--------|
| Heater voltage | $V_f$ | 6.3 V  |
| Heater current | $I_f$ | 200 mA |

### DIMENSIONS AND CONNECTIONS

Dimensions in mm

Base: Noval

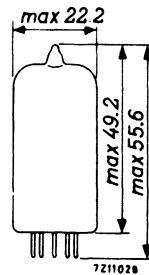
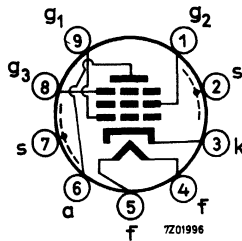

### CAPACITANCES

|                               |              |                |
|-------------------------------|--------------|----------------|
| Grid No.1 to all except anode | $C_{g_1(a)}$ | 3.8 pF         |
| Anode to all except grid No.1 | $C_{a(g_1)}$ | 5.1 pF         |
| Anode to grid No.1            | $C_{ag_1}$   | max. 0.05 pF   |
| Grid No.1 to heater           | $C_{g_1f}$   | max. 0.0025 pF |

**TYPICAL CHARACTERISTICS**

|                      |              |                |
|----------------------|--------------|----------------|
| Anode voltage        | $V_a$        | 250 V          |
| Grid No.3 voltage    | $V_{g3}$     | 0 V            |
| Grid No.2 voltage    | $V_{g2}$     | 140 V          |
| Grid No.1 voltage    | $V_{g1}$     | -2.2 V         |
| Anode current        | $I_a$        | 3.0 mA         |
| Grid No.2 current    | $I_{g2}$     | 0.6 mA         |
| Transconductance     | S            | 2.2 mA/V       |
| Amplification factor | $\mu_{g2g1}$ | 38 -           |
| Internal resistance  | $R_i$        | 2.5 M $\Omega$ |

**OPERATING CHARACTERISTICS as A.F. amplifier**

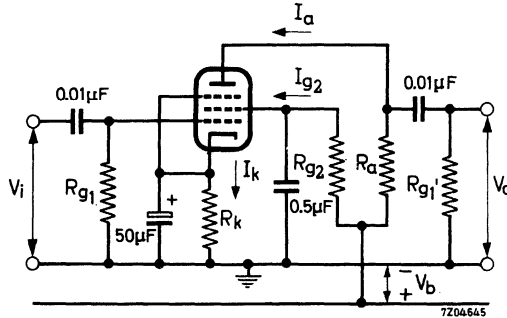

|                          |           |      |      |      |      |      |      |                  |
|--------------------------|-----------|------|------|------|------|------|------|------------------|
| Supply voltage           | $V_b$     | 400  | 350  | 300  | 250  | 200  | 150  | V                |
| Anode resistor           | $R_a$     | 100  | 100  | 100  | 100  | 100  | 100  | k $\Omega$       |
| Grid No.2 resistor       | $R_{g2}$  | 390  | 390  | 390  | 390  | 390  | 390  | k $\Omega$       |
| Cathode resistor         | $R_k$     | 1000 | 1000 | 1000 | 1000 | 1000 | 1000 | $\Omega$         |
| Grid resistor next stage | $R_{g1}'$ | 330  | 330  | 330  | 330  | 330  | 330  | k $\Omega$       |
| Cathode current          | $I_k$     | 3.2  | 2.75 | 2.4  | 2.0  | 1.55 | 1.05 | mA               |
| Voltage gain 1)          | $V_o/V_i$ | 140  | 134  | 129  | 123  | 117  | 110  | -                |
| Output voltage           | $V_o$     | 85   | 74   | 62   | 50   | 38   | 27   | V <sub>RMS</sub> |
| Total distortion         | $d_{tot}$ | 5    | 5    | 5    | 5    | 5    | 5    | %                |

1) Measured at small input voltages



**OPERATING CHARACTERISTICS (continued)**

|                          |            |      |      |      |      |      |      |           |
|--------------------------|------------|------|------|------|------|------|------|-----------|
| Supply voltage           | $V_b$      | 400  | 350  | 300  | 250  | 200  | 150  | V         |
| Anode resistor           | $R_a$      | 220  | 220  | 220  | 220  | 220  | 220  | $k\Omega$ |
| Grid No.2 resistor       | $R_{g_2}$  | 1    | 1    | 1    | 1    | 1    | 1    | $M\Omega$ |
| Cathode resistor         | $R_k$      | 2200 | 2200 | 2200 | 2200 | 2200 | 2200 | $\Omega$  |
| Grid resistor next stage | $R_{g'_1}$ | 680  | 680  | 680  | 680  | 680  | 680  | $k\Omega$ |
| Cathode current          | $I_k$      | 1.45 | 1.3  | 1.1  | 0.9  | 0.75 | 0.5  | mA        |
| Voltage gain 1)          | $V_o/V_i$  | 210  | 205  | 194  | 185  | 173  | 147  | -         |
| Output voltage           | $V_o$      | 72   | 62   | 53   | 44   | 35   | 22   | $V_{RMS}$ |
| Total distortion         | $d_{tot}$  | 5    | 5    | 5    | 5    | 5    | 5    | %         |

As triode connected A.F. amplifier ( $g_2$  connected to anode,  $g_3$  to cathode)

|                                     |            |      |      |      |      |      |           |
|-------------------------------------|------------|------|------|------|------|------|-----------|
| Supply voltage                      | $V_b$      | 400  | 350  | 300  | 250  | 200  | V         |
| Anode resistor                      | $R_a$      | 47   | 47   | 47   | 47   | 47   | $k\Omega$ |
| Cathode resistor                    | $R_k$      | 1200 | 1200 | 1200 | 1200 | 1200 | $\Omega$  |
| Grid resistor next stage            | $R_{g'_1}$ | 150  | 150  | 150  | 150  | 150  | $k\Omega$ |
| Anode current                       | $I_a$      | 3.6  | 3.15 | 2.7  | 2.25 | 1.8  | mA        |
| Voltage gain                        | $V_o/V_i$  | 26   | 25   | 25   | 25   | 24   | -         |
| Output voltage ( $I_g = 0.3\mu A$ ) | $V_o$      | 68   | 58   | 46   | 36   | 24   | $V_{RMS}$ |
| Total distortion                    | $d_{tot}$  | 5    | 5    | 5    | 5    | 5    | %         |

|                                     |            |      |      |      |      |      |           |
|-------------------------------------|------------|------|------|------|------|------|-----------|
| Supply voltage                      | $V_b$      | 400  | 350  | 300  | 250  | 200  | V         |
| Anode resistor                      | $R_a$      | 100  | 100  | 100  | 100  | 100  | $k\Omega$ |
| Cathode resistor                    | $R_k$      | 2200 | 2200 | 2200 | 2200 | 2200 | $\Omega$  |
| Grid resistor next stage            | $R_{g'_1}$ | 330  | 330  | 330  | 330  | 330  | $k\Omega$ |
| Anode current                       | $I_a$      | 2.0  | 1.8  | 1.5  | 1.25 | 1.0  | mA        |
| Voltage gain                        | $V_o/V_i$  | 28   | 28   | 27.5 | 27.5 | 27   | -         |
| Output voltage ( $I_g = 0.3\mu A$ ) | $V_o$      | 75   | 63   | 51   | 42   | 30   | $V_{RMS}$ |
| Total distortion                    | $d_{tot}$  | 5    | 5    | 5    | 5    | 5    | %         |

|                                     |            |      |      |      |      |      |           |
|-------------------------------------|------------|------|------|------|------|------|-----------|
| Supply voltage                      | $V_b$      | 400  | 350  | 300  | 250  | 200  | V         |
| Anode resistor                      | $R_a$      | 220  | 220  | 220  | 220  | 220  | $k\Omega$ |
| Cathode resistor                    | $R_k$      | 3900 | 3900 | 3900 | 3900 | 3900 | $\Omega$  |
| Grid resistor next stage            | $R_{g'_1}$ | 680  | 680  | 680  | 680  | 680  | $k\Omega$ |
| Anode current                       | $I_a$      | 1.1  | 0.95 | 0.8  | 0.7  | 0.55 | mA        |
| Voltage gain                        | $V_o/V_i$  | 29   | 29   | 29   | 28   | 28   | -         |
| Output voltage ( $I_g = 0.3\mu A$ ) | $V_o$      | 71   | 60   | 52   | 42   | 30   | $V_{RMS}$ |
| Total distortion                    | $d_{tot}$  | 5    | 5    | 5    | 5    | 5    | %         |

**OPERATING CHARACTERISTICS (continued)**

Microphonic effect

A sensitivity of 0.5 mV for an output of 50 mW (or 5 mV for an output of 5 W) is permissible in those equipments where an output of 50 mW in the loudspeaker does not produce an average acceleration on the tube higher than 0.015 g at any frequency higher than 500 Hz or higher than 0.06 g at any frequency lower than 500 Hz.

Hum level

The hum disturbance level will be 3  $\mu$ V (max. 5  $\mu$ V) when  $Z_{g1}$  is smaller than 0.5 M $\Omega$  at f = 50 Hz, the cathode resistor is decoupled by a capacitor of at least 100  $\mu$ F and pin 4 is earthed. With the centre tap of the heater supply earthed this value will be 1  $\mu$ V (max. 2  $\mu$ V).

Noise voltage

The equivalent noise voltage on  $g_1$  is approximately 2  $\mu$ V for the frequency range from 25 to 10 000 Hz at  $V_b = 250$  V and  $R_a = 100$  k $\Omega$ .

**LIMITING VALUES (Design centre rating system)**

|                            |           |                    |
|----------------------------|-----------|--------------------|
| Anode voltage              | $V_{a0}$  | max. 550 V         |
|                            | $V_a$     | max. 300 V         |
| Anode dissipation          | $W_a$     | max. 1.0 W         |
| Grid No.2 voltage          | $V_{g20}$ | max. 550 V         |
|                            | $V_{g2}$  | max. 200 V         |
| Grid No.2 dissipation      | $W_{g2}$  | max. 0.2 W         |
| Grid No.1 circuit resistor |           |                    |
| if $W_a < 0.2$ W           | $R_{g1}$  | max. 10 M $\Omega$ |
| if $W_a > 0.2$ W           | $R_{g1}$  | max. 3 M $\Omega$  |
| with grid current biasing  | $R_{g1}$  | max. 22 M $\Omega$ |
| Cathode current            | $I_k$     | max. 6 mA          |
| Cathode to heater voltage  |           |                    |
| cathode positive           | $V_{kf}$  | max. 100 V         |
| cathode negative           | $V_{kf}$  | max. 50 V          |

## R.F. PENTODE

Pentode with variable transconductance intended for use as R.F. or I.F. amplifier.

| QUICK REFERENCE DATA |                |                |
|----------------------|----------------|----------------|
| Anode current        | $I_a$          | 9 mA           |
| Transconductance     | S              | 4.0 mA/V       |
| Amplification factor | $\mu_{g_2g_1}$ | 21 -           |
| Internal resistance  | $R_i$          | 750 k $\Omega$ |

**HEATING:** Indirect by A.C. or D.C.; parallel supply

|                |       |        |
|----------------|-------|--------|
| Heater voltage | $V_f$ | 6.3 V  |
| Heater current | $I_f$ | 200 mA |

### DIMENSIONS AND CONNECTIONS

Dimensions in mm

Base: Noval

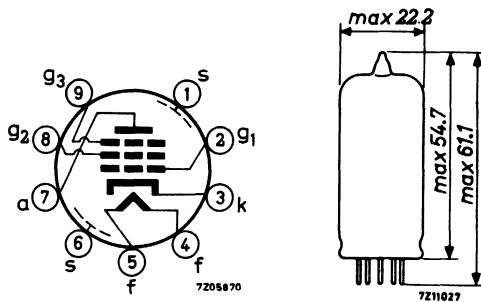

### CAPACITANCES

|                                |              |               |
|--------------------------------|--------------|---------------|
| Anode to all except grid No. 1 | $C_a(g_1)$   | 5.1 pF        |
| Grid No. 1 to all except anode | $C_{g_1(a)}$ | 5.5 pF        |
| Anode to grid No. 1            | $C_{ag_1}$   | max. 0.002 pF |
| Grid No. 1 to heater           | $C_{g_1f}$   | 0.05 pF       |

**TYPICAL CHARACTERISTICS**

|                      |              |     |                    |                    |           |
|----------------------|--------------|-----|--------------------|--------------------|-----------|
| Anode voltage        | $V_a$        | 250 | 250                | 170                | V         |
| Grid No. 2 voltage   | $V_{g2}$     | 100 | 85                 | 100                | V         |
| Grid No. 3 voltage   | $V_{g3}$     | 0   | 0                  | 0                  | V         |
| Anode current        | $I_a$        | 9   | 9                  | 12                 | mA        |
| Grid No. 1 voltage   | $V_{g1}$     | -2  | -1.2 <sup>1)</sup> | -1.2 <sup>1)</sup> | V         |
| Grid No. 2 current   | $I_{g2}$     | 3   | 3.2                | 4.4                | mA        |
| Transconductance     | S            | 3.6 | 4.0                | 4.4                | mA/V      |
| Internal resistance  | $R_i$        | 0.9 | 0.75               | 0.4                | $M\Omega$ |
| Amplification factor | $\mu_{g2g1}$ | -   | 21                 | -                  | -         |

**OPERATING CHARACTERISTICS**

|                                |             |       |      |       |           |           |
|--------------------------------|-------------|-------|------|-------|-----------|-----------|
| Anode voltage, supply voltage  | $V_a = V_b$ | 250   |      | 200   | V         |           |
| Grid No. 3 voltage             | $V_{g3}$    | 0     |      | 0     | V         |           |
| Grid No. 2 resistor            | $R_{g2}$    | 51    |      | 24    | $k\Omega$ |           |
| Cathode resistor               | $R_k$       | 160   |      | 130   | $\Omega$  |           |
| Grid No. 1 voltage             | $V_{g1}$    | -1.95 | -20  | -1.95 | -20       | V         |
| Anode current                  | $I_a$       | 9     | -    | 11.1  | -         | mA        |
| Grid No. 2 current             | $I_{g2}$    | 3     | -    | 3.8   | -         | mA        |
| Transconductance               | S           | 3.5   | 0.24 | 3.85  | 0.16      | mA/V      |
| Internal resistance            | $R_i$       | 0.9   | -    | 0.55  | -         | $M\Omega$ |
| Equivalent noise resistance    | $R_{eq}$    | 4.2   | -    | 4.2   | -         | $k\Omega$ |
| Input conductance (f = 50 MHz) | g           | 95    | -    | 102   | -         | $\mu A/V$ |

<sup>1)</sup> In this case control grid current may occur. If this is not permissible, the negative grid bias should be increased to a value of 1.5 V at least.

**OPERATING CHARACTERISTICS** (continued)

|                               |             |                   |                   |            |      |            |
|-------------------------------|-------------|-------------------|-------------------|------------|------|------------|
| Anode voltage, supply voltage | $V_a = V_b$ | 250 <sup>1)</sup> | 200 <sup>1)</sup> | V          |      |            |
| Grid No. 3 voltage            | $V_{g3}$    | 0                 | 0                 | V          |      |            |
| Grid No. 2 resistor           | $R_{g2}$    | 62                | 33                | k $\Omega$ |      |            |
| Cathode resistor              | $R_k$       | 0                 | 0                 | $\Omega$   |      |            |
| Grid No. 1 resistor           | $R_{g1}$    | 10                | 10                | M $\Omega$ |      |            |
| Control voltage               | $V_{R(g1)}$ | 0                 | -20               | 0          | -20  | V          |
| Anode current                 | $I_a$       | 9                 | -                 | 11.25      | -    | mA         |
| Grid No. 2 current            | $I_{g2}$    | 2.9               | -                 | 3.9        | -    | mA         |
| Transconductance              | S           | 4.7               | 0.22              | 5.15       | 0.15 | mA/V       |
| Internal resistance           | $R_i$       | 825               | -                 | 550        | -    | k $\Omega$ |
| Equivalent noise resistance   | $R_{eq}$    | 2.4               | -                 | 2.5        | -    | k $\Omega$ |

**LIMITING VALUES** (Design centre rating system)

|                           |           |      |      |            |
|---------------------------|-----------|------|------|------------|
| Anode voltage             | $V_{a0}$  | max. | 550  | V          |
|                           | $V_a$     | max. | 300  | V          |
| Anode dissipation         | $W_a$     | max. | 2.25 | W          |
| Grid No. 2 voltage        | $V_{g20}$ | max. | 550  | V          |
|                           | $V_{g2}$  | max. | 300  | V          |
| Grid No. 2 dissipation    | $W_{g2}$  | max. | 0.45 | W          |
| Cathode current           | $I_k$     | max. | 16.5 | mA         |
| Grid No. 1 resistor       | $R_{g1}$  | max. | 3    | M $\Omega$ |
| Grid No. 3 resistor       | $R_{g3}$  | max. | 10   | k $\Omega$ |
| Cathode to heater voltage | $V_{kf}$  | max. | 100  | V          |

<sup>1)</sup> In this case control grid current may occur. If this is not permissible, the negative grid bias should be increased to a value of 1.5 V at least.



## I.F. PENTODE

Pentode with variable transconductance intended for use as I.F. amplifier in television receivers.

| QUICK REFERENCE DATA |       |                |
|----------------------|-------|----------------|
| Anode current        | $I_a$ | 12 mA          |
| Transconductance     | S     | 12.5 mA/V      |
| Internal resistance  | $R_i$ | 500 k $\Omega$ |

**HEATING:** Indirect by A.C. or D.C.; parallel or series supply

|                |       |        |
|----------------|-------|--------|
| Heater voltage | $V_f$ | 6.3 V  |
| Heater current | $I_f$ | 300 mA |

### DIMENSIONS AND CONNECTIONS

Dimensions in mm

Base: Noval

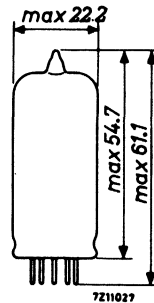
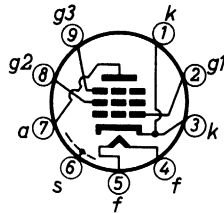

### CAPACITANCES

|                                |              |               |
|--------------------------------|--------------|---------------|
| Anode to all except grid No. 1 | $C_a(g_1)$   | 3 pF          |
| Grid No. 1 to all except anode | $C_{g_1(a)}$ | 9.5 pF        |
| Anode to grid No. 1            | $C_{ag_1}$   | max. 0.005 pF |
| Grid No. 1 to grid No. 2       | $C_{g_1g_2}$ | 2.8 pF        |

**TYPICAL CHARACTERISTICS**

|  |          |               |
|--|----------|---------------|
| Anode voltage                                  | $V_a$    | 200 V         |
| Grid No. 3 voltage                             | $V_{g3}$ | 0 V           |
| Grid No. 2 voltage                             | $V_{g2}$ | 90 V          |
| Grid No. 1 voltage                             | $V_{g1}$ | -2 V          |
| Anode current                                  | $I_a$    | 12 mA         |
| Grid No. 2 current                             | $I_{g2}$ | 4.5 mA        |
| Transconductance                               | $S$      | 12.5 mA/V     |
| Internal resistance                            | $R_i$    | 500 $k\Omega$ |
| Input resistance grid No. 1<br>( $f = 40$ MHz) | $r_{g1}$ | 13 $k\Omega$  |
| Equivalent noise resistance<br>( $f = 40$ MHz) | $R_{eq}$ | 490 $\Omega$  |

**OPERATING CHARACTERISTICS**

|                           |           |      |      |      |           |      |     |      |
|---------------------------|-----------|------|------|------|-----------|------|-----|------|
| Anode voltage             | $V_a$     | 170  | 200  | 230  | V         |      |     |      |
| Grid No. 3 voltage        | $V_{g3}$  | 0    | 0    | 0    | V         |      |     |      |
| Grid No. 2 supply voltage | $V_{bg2}$ | 170  | 200  | 230  | V         |      |     |      |
| Grid No. 2 resistor       | $R_{g2}$  | 15   | 24   | 39   | $k\Omega$ |      |     |      |
| Grid No. 1 voltage        | $V_{g1}$  | -1.8 | -7.5 | -2.0 | -9.5      | -2.1 | -12 | V    |
| Anode current             | $I_a$     | 14   | 2.7  | 12   | 2.7       | 10.5 | 2.4 | mA   |
| Transconductance          | $S$       | 14   | 0.7  | 12.5 | 0.62      | 10.6 | 0.5 | mA/V |

**REMARK**

Operation with cathode bias resistor and/or screen grid resistor is recommended.



**LIMITING VALUES** (Design centre rating system)

|                                  |            |      |              |
|----------------------------------|------------|------|--------------|
| Anode voltage                    | $V_{a0}$   | max. | 550 V        |
|                                  | $V_a$      | max. | 250 V        |
| Anode dissipation                | $W_a$      | max. | 2.5 W        |
| Grid No.2 voltage                | $V_{g20}$  | max. | 550 V        |
|                                  | $V_{g2}$   | max. | 250 V        |
| Grid No.2 dissipation            | $W_{g2}$   | max. | 0.65 W       |
| Grid No.1 voltage, negative peak | $-V_{g1p}$ | max. | 50 V         |
| Cathode current                  | $I_k$      | max. | 20 mA        |
| Cathode to heater voltage        | $V_{kf}$   | max. | 150 V        |
| Grid No.3 resistor               | $R_{g3}$   | max. | 50 $k\Omega$ |
| Grid No.1 resistor               | $R_{g1}$   | max. | 1 $M\Omega$  |

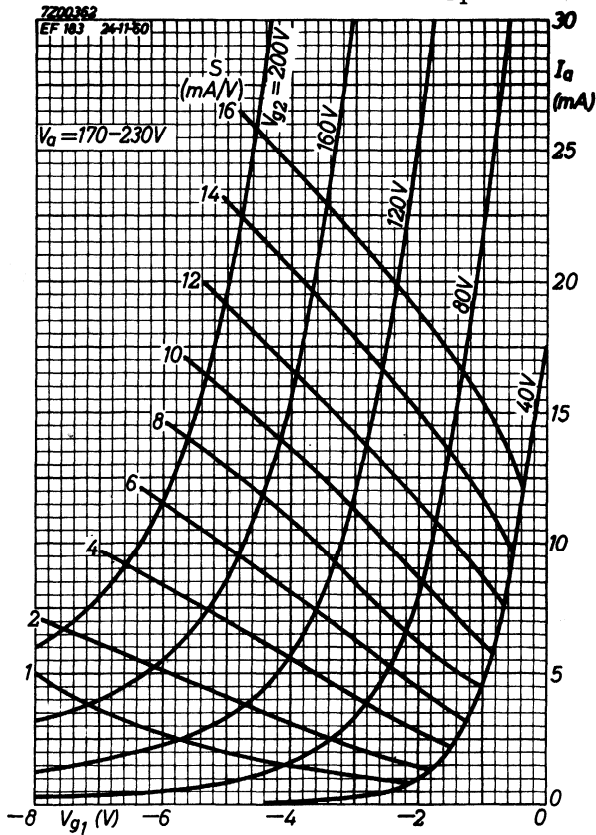

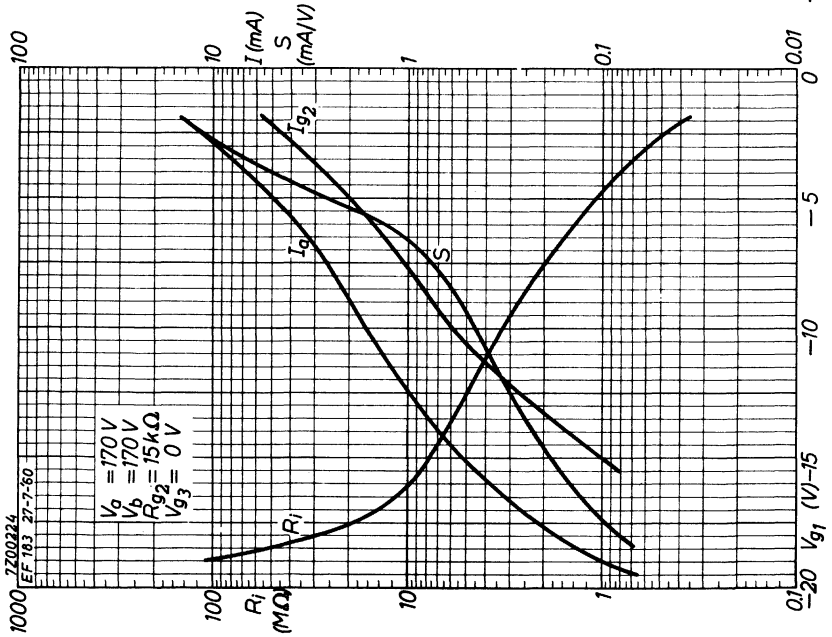
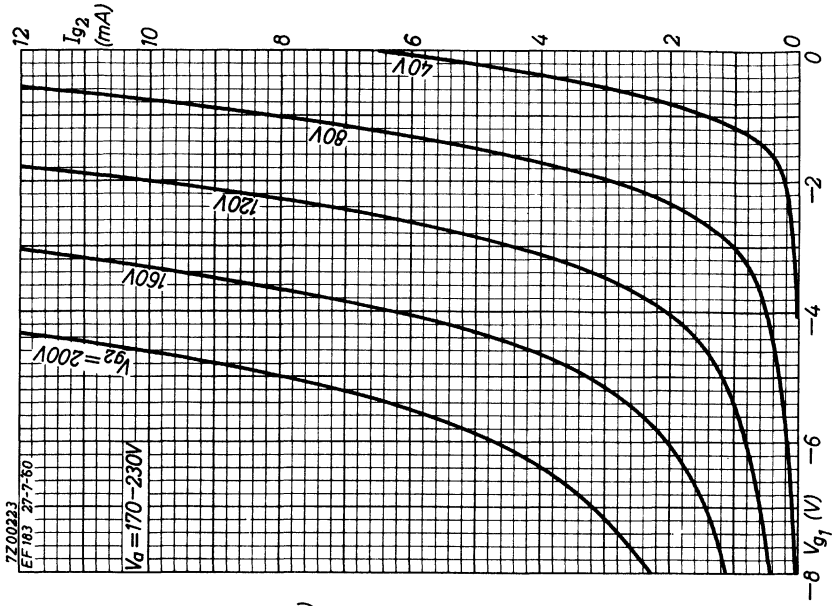

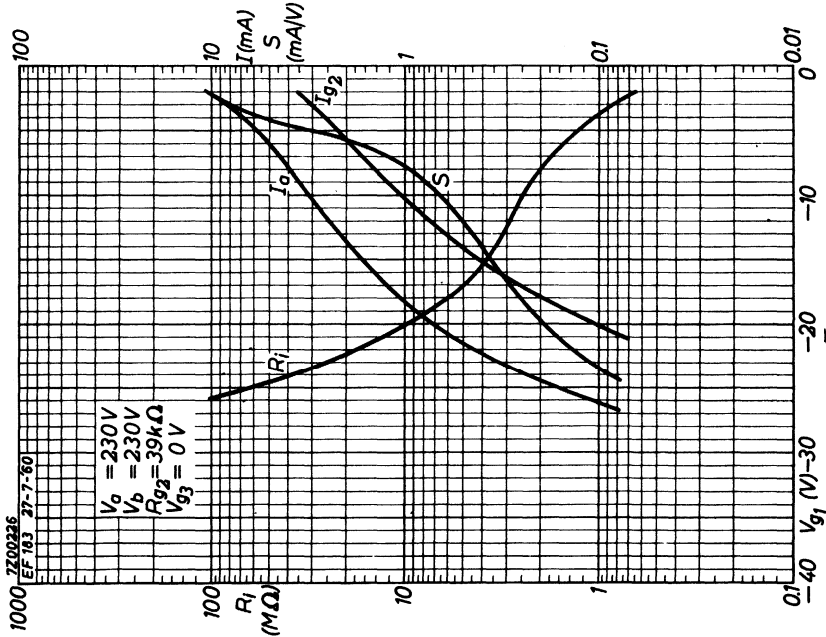
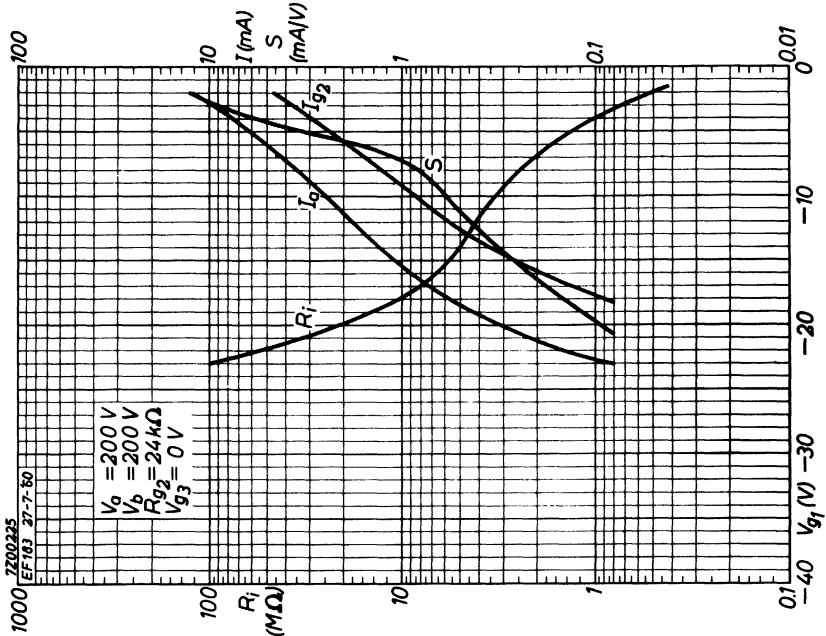

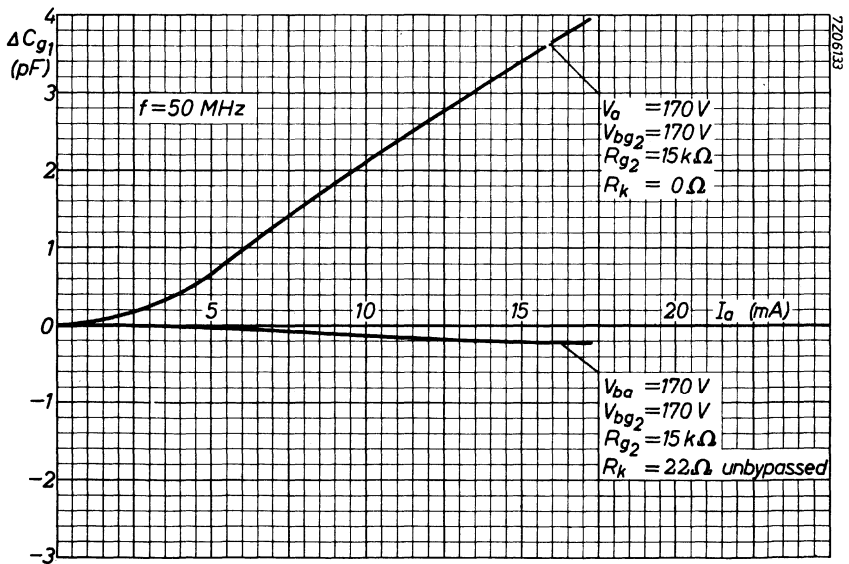
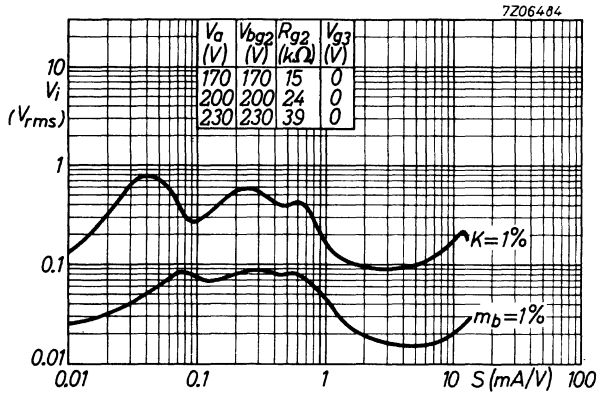

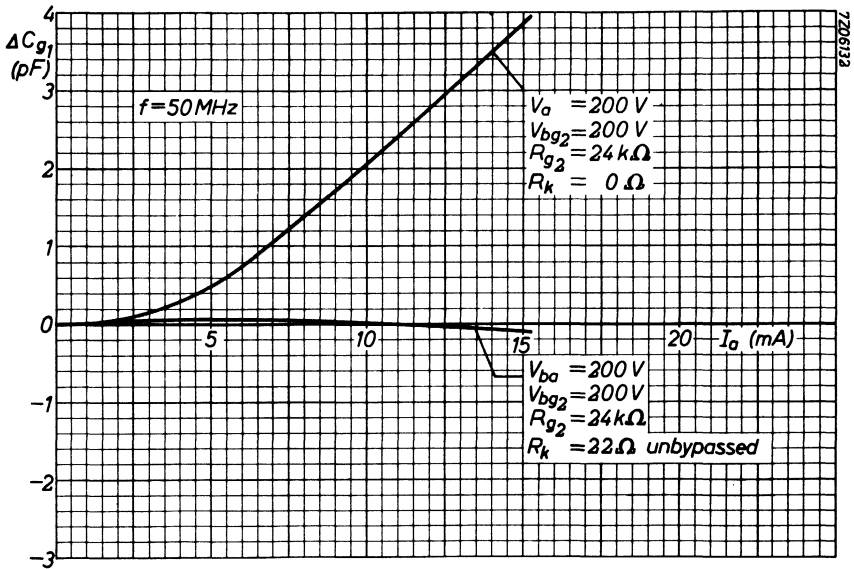



## I.F. PENTODE

Pentode intended for use as I.F. amplifier in television receivers.

| QUICK REFERENCE DATA |                |                |
|----------------------|----------------|----------------|
| Anode current        | $I_a$          | 10 mA          |
| Transconductance     | S              | 15 mA/V        |
| Amplification factor | $\mu_{g_2g_1}$ | 60 -           |
| Internal resistance  | $R_i$          | 380 k $\Omega$ |

**HEATING:** Indirect by A.C. or D.C.; parallel or series supply

|                |       |        |
|----------------|-------|--------|
| Heater voltage | $V_f$ | 6.3 V  |
| Heater current | $I_f$ | 300 mA |

### DIMENSIONS AND CONNECTIONS

Dimensions in mm

Base: Noval

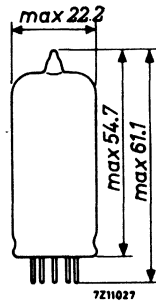
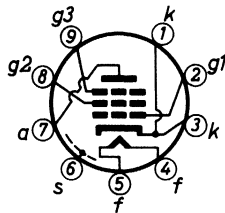

### CAPACITANCES

|                               |              |                |
|-------------------------------|--------------|----------------|
| Anode to all except grid No.1 | $C_{a(g_1)}$ | 3 pF           |
| Grid No.1 to all except anode | $C_{g_1(a)}$ | 10 pF          |
| Anode to grid No.1            | $C_{ag_1}$   | max. 0.0055 pF |
| Grid No.1 to grid No.2        | $C_{g_1g_2}$ | 2.8 pF         |

**TYPICAL CHARACTERISTICS**

|  |              |      |           |
|--|--------------|------|-----------|
| Anode voltage                            | $V_a$        | 200  | V         |
| Grid No.3 voltage                        | $V_{g3}$     | 0    | V         |
| Grid No.2 voltage                        | $V_{g2}$     | 200  | V         |
| Grid No.1 voltage                        | $V_{g1}$     | -2.5 | V         |
| Anode current                            | $I_a$        | 10   | mA        |
| Grid No.2 current                        | $I_{g2}$     | 4.1  | mA        |
| Transconductance                         | $S$          | 15   | mA/V      |
| Internal resistance                      | $R_i$        | 380  | $k\Omega$ |
| Amplification factor                     | $\mu_{g2g1}$ | 60   | -         |
| Input resistance grid No.1 (f = 40 MHz)  | $r_{g1}$     | 11   | $k\Omega$ |
| Equivalent noise resistance (f = 40 MHz) | $R_{eq}$     | 330  | $\Omega$  |

**OPERATING CHARACTERISTICS**

|   |           |      |      |      |           |
|---|-----------|------|------|------|-----------|
| Anode supply coltage                      | $V_{ba}$  | 170  | 200  | 230  | V         |
| Grid No.3 voltage                         | $V_{g3}$  | 0    | 0    | 0    | V         |
| Grid No.2 supply voltage                  | $V_{bg2}$ | 170  | 200  | 230  | V         |
| Grid No.2 resistor                        | $R_{g2}$  | 0    | 7.5  | 15   | $k\Omega$ |
| Cathode resistor                          | $R_k$     | 140  | 140  | 140  | $\Omega$  |
| Anode current                             | $I_a$     | 10   | 10   | 10   | mA        |
| Grid No.2 current                         | $I_{g2}$  | 4.1  | 4.1  | 4.1  | mA        |
| Transconductance                          | $S$       | 15.6 | 15.6 | 15.6 | mA/V      |
| Internal resistance                       | $R_i$     | 330  | 510  | 680  | $k\Omega$ |
| Input resistance grid No.1<br>f = 40 MHz  | $r_{g1}$  | 10   | 10   | 10   | $k\Omega$ |
| Equivalent noise resistance<br>f = 40 MHz | $R_{eq}$  | 300  | 300  | 300  | $\Omega$  |

**REMARKS**

1. Operation with cathode bias resistor is recommended.
2. In order to ensure a good performance with respect to cross-modulation and microphony this tube should not be used in circuits with automatic gain control. For such applications a tube with variable transconductance is recommended.



**LIMITING VALUES** (Design centre rating system)

|                                  |            |                          |
|----------------------------------|------------|--------------------------|
| Anode voltage                    | $V_{a0}$   | max. 550 V               |
|                                  | $V_a$      | max. 250 V               |
| Anode dissipation                | $W_a$      | max. 2.5 W               |
| Grid No.2 voltage                | $V_{g20}$  | max. 550 V               |
|                                  | $V_{g2}$   | max. 250 V               |
| Grid No.2 dissipation            | $W_{g2}$   | max. 0.9 W <sup>1)</sup> |
| Grid No.1 voltage, negative peak | $-V_{g1p}$ | max. 50 V                |
| Cathode current                  | $I_k$      | max. 25 mA               |
| Cathode to heater voltage        | $V_{kf}$   | max. 150 V               |
| Grid No.1 resistor               | $R_{g1}$   | max. 1 M $\Omega$        |

<sup>1)</sup> During a heating-up period not exceeding 15 seconds this value may be max. 1.5 W. At the values of  $R_{g2}$  specified under "Operating characteristics" there will be no risk of exceeding the maximum permissible value of  $W_{g2}$ .

7Z00363

EF 184 24-11-60

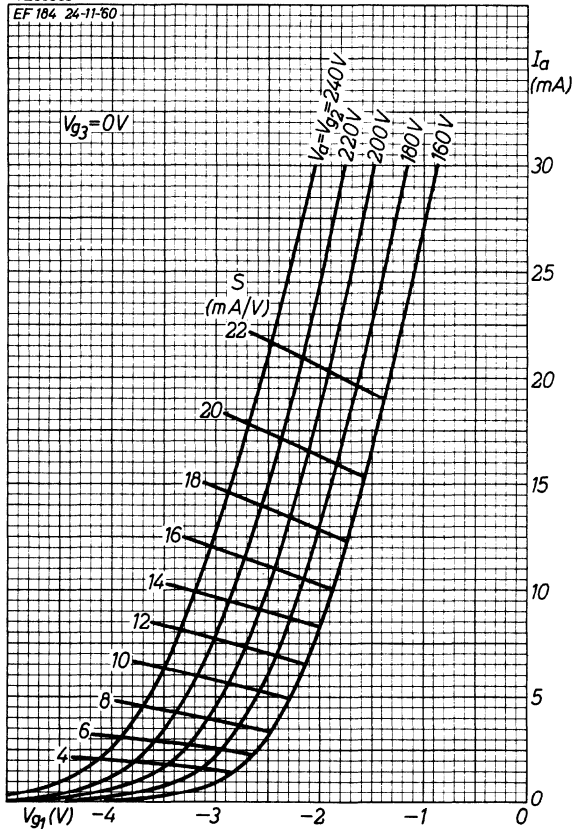

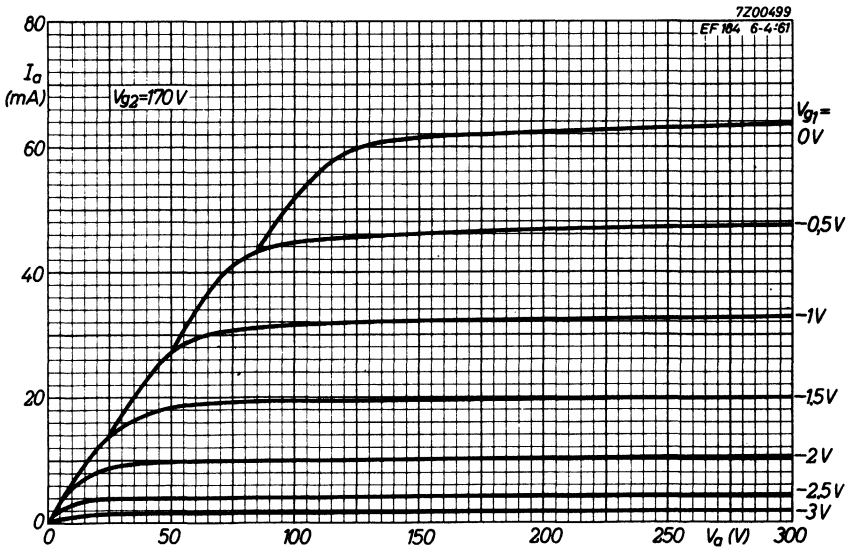
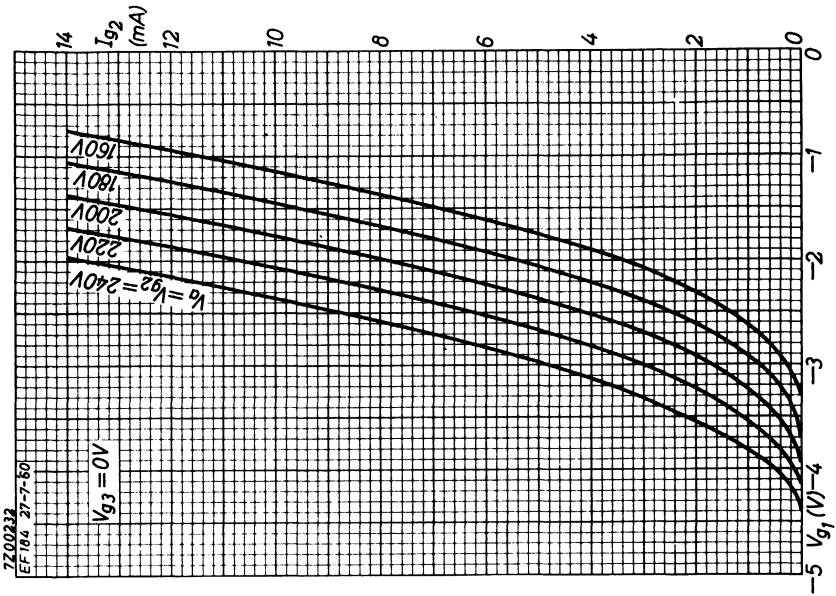

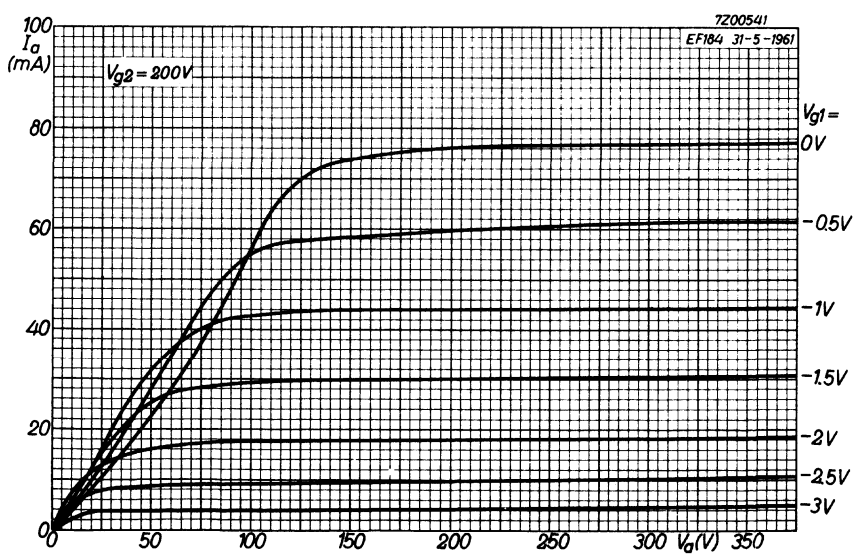
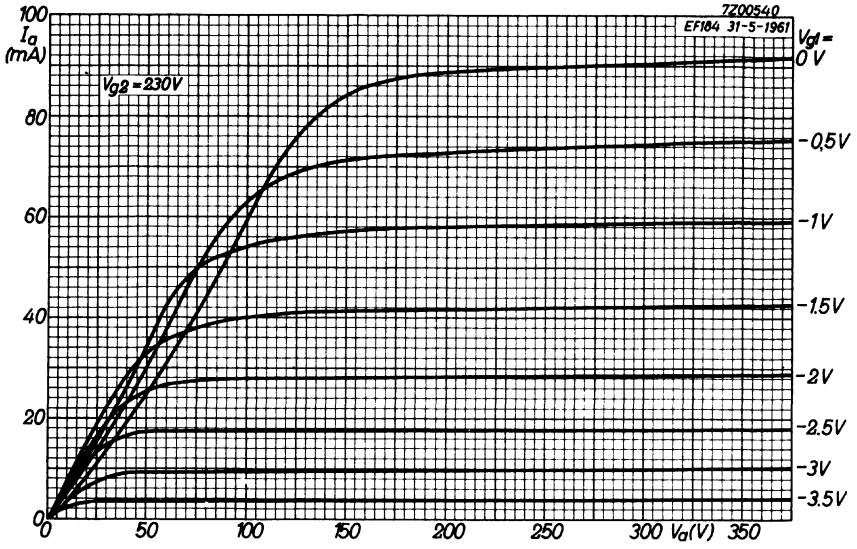

**DOUBLE PENTODE**

Double pentode intended for use as video output tube and as sync separator, A.G.C. amplifier or I.F. sound amplifier.

**HEATING:** Indirect by A.C. or D.C.; parallel supply

Heater voltage

$V_f$  6.3 V

Heater current

$I_f$  810 mA

-----  
For further data and curves of this type  
please refer to type PFL200  
-----



## A.F. OUTPUT PENTODE

Pentode intended for use as A.F. power amplifier.

| QUICK REFERENCE DATA  |                |           |
|-----------------------|----------------|-----------|
| Anode current         | $I_a$          | 100 mA    |
| Transconductance      | $S$            | 12.5 mA/V |
| Amplification factor  | $\mu_{g_2g_1}$ | 11        |
| Output power, class B |                | 100 W     |

**HEATING:** Indirect by A.C. or D.C.; parallel supply

|                |       |       |
|----------------|-------|-------|
| Heater voltage | $V_f$ | 6.3 V |
| Heater current | $I_f$ | 1.5 A |

### DIMENSIONS AND CONNECTIONS

Dimensions in mm

Base: Octal

Socket: 5903/13

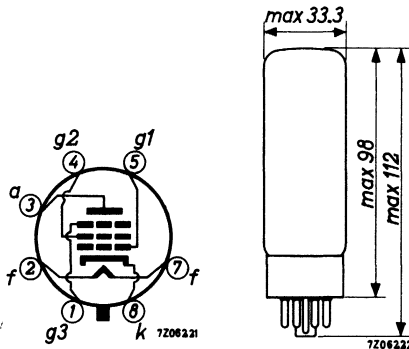

**CAPACITANCES**

|                               |              |             |
|-------------------------------|--------------|-------------|
| Anode to all except grid No.1 | $C_{a(g_1)}$ | 8.4 pF      |
| Grid No.1 to all except anode | $C_{g_1(a)}$ | 15.2 pF     |
| Anode to grid No.1            | $C_{ag_1}$   | max. 1.1 pF |
| Grid No.1 to heater           | $C_{g_1f}$   | max. 1.0 pF |
| Cathode to heater             | $C_{kf}$     | 10 pF       |

**OPERATING CHARACTERISTICS**

Class A

|  |                |       |                      |
|--|----------------|-------|----------------------|
| Supply voltage                                 | $V_b$          | 265   | 265 V                |
| Anode voltage                                  | $V_a$          | 250   | 250 V                |
| Grid No.2 series resistor                      | $R_{g_2}$      | 2     | 0 k $\Omega$         |
| Grid No.3 voltage                              | $V_{g_3}$      | 0     | 0 V                  |
| Grid No.1 voltage                              | $V_{g_1}$      | -14.5 | -13.5 V              |
| Anode current                                  | $I_a$          | 70    | 100 mA               |
| Grid No.2 current                              | $I_{g_2}$      | 10    | 14.9 mA              |
| Transconductance                               | $S$            | 11    | 12.5 mA/V            |
| Amplification factor                           | $\mu_{g_2g_1}$ | 11    | 11                   |
| Internal resistance                            | $R_i$          | 20    | 17 k $\Omega$        |
| Load resistance                                | $R_{a\sim}$    | 3.0   | 2.0 k $\Omega$       |
| Grid No.1 driving voltage                      | $V_i$          | 9.3   | 8.7 V <sub>RMS</sub> |
| Output power                                   | $W_o$          | 8     | 11 W                 |
| Distortion                                     | $d_{tot}$      | 10    | 10 %                 |
| Grid No.1 driving voltage<br>for $W_o = 50$ mW | $V_i$          | 0.65  | 0.5 V <sub>RMS</sub> |



**OPERATING CHARACTERISTICS**

Class B, two tubes in push-pull

Common grid No.2  
series resistor  
(non decoupled)

|                           |              |       |       |       |                       |
|---------------------------|--------------|-------|-------|-------|-----------------------|
| $R_{g2}$                  | 1000         |       |       | 470   | $\Omega$              |
| Grid No.1 voltage         | $V_{g1}$     | -38   |       | -32   | V                     |
| Grid No.3 voltage         | $V_{g3}$     | 0     |       | 0     | V                     |
| Grid No.1 driving voltage | $V_i$        | 0     | 27    | 27    | 0 22.7 22.7 $V_{RMS}$ |
| Load resistance           | $R_{aa\sim}$ | -     | 3.4   | 4.0   | - 2.8 3.8 $k\Omega$   |
| Supply voltage            | $V_b$        | 425   | 425   | 400   | 375 375 350 V         |
| Anode voltage             | $V_a$        | 420   | 400   | 375   | 370 350 325 V         |
| Anode current             | $I_a$        | 2x30  | 2x120 | 2x100 | 2x35 2x120 2x93 mA    |
| Grid No.2 current         | $I_{g2}$     | 2x4.4 | 2x25  | 2x25  | 2x4.7 2x25 2x25 mA    |
| Output power              | $W_o$        | 0     | 55    | 45    | 0 44 36 W             |
| Distortion                | $d_{tot}$    | -     | 5     | 6     | - 5 6 %               |

Common grid No.2  
series resistor  
(non decoupled)

|                           |              |      |       |       |                       |
|---------------------------|--------------|------|-------|-------|-----------------------|
| $R_{g2}$                  | 750          |      |       | 750   | $\Omega$              |
| Grid No.1 voltage         | $V_{g1}$     | -36  |       | -39   | V                     |
| Grid No.3 voltage         | $V_{g3}$     | 0    |       | 0     | V                     |
| Grid No.1 driving voltage | $V_i$        | 0    | 25.8  | 25.8  | 0 23.4 23.4 $V_{RMS}$ |
| Load resistance           | $R_{aa\sim}$ | -    | 4     | 5     | - 11 11 $k\Omega$     |
| Anode supply voltage      | $V_{ba}$     | 500  | 500   | 475   | 800 800 750 V         |
| Anode voltage             | $V_a$        | 495  | 475   | 450   | 795 775 725 V         |
| Grid No.2 supply voltage  | $V_{bg2}$    | 400  | 400   | 375   | 400 400 375 V         |
| Anode current             | $I_a$        | 2x30 | 2x125 | 2x102 | 2x25 2x91 2x84 mA     |
| Grid No.2 current         | $I_{g2}$     | 2x4  | 2x25  | 2x25  | 2x3 2x19 2x19 mA      |
| Output power              | $W_o$        | 0    | 70    | 58    | 0 100 90 W            |
| Distortion                | $d_{tot}$    | -    | 5     | 6     | - 5 6 %               |

**OPERATING CHARACTERISTICS**

Class AB, two tubes in push-pull

|   |                |        |              |
|---|----------------|--------|--------------|
| Load resistance                                     | $R_{aa\sim}$   | 3.4    | $k\Omega$    |
| Common grid No.2 series resistor<br>(non decoupled) | $R_{g2}$       | 470    | $\Omega$     |
| Common cathode resistor                             | $R_k$          | 130    | $\Omega$     |
| Grid No.3 voltage                                   | $V_{g3}$       | 0 V    |              |
| Grid No.1 driving voltage                           | $V_i$          | 0      | 21 $V_{RMS}$ |
| Supply voltage                                      | $V_b$          | 375    | 375 V        |
| Anode to earth voltage                              | $V_a + V_{Rk}$ | 355    | 350 V        |
| Anode current                                       | $I_a$          | 2x75   | 2x95 mA      |
| Grid No.2 current                                   | $I_{g2}$       | 2x11.5 | 2x22.5 mA    |
| Output power  | $W_o$          | 0      | 35 W         |
| Distortion  | $d_{tot}$      | -      | 5 %          |

**LIMITING VALUES** (Design centre rating system)

|                           |                    |          |                    |
|---------------------------|--------------------|----------|--------------------|
| Anode voltage             | $V_{a0}$           | max.     | 2000 V             |
|                           | $V_a$              | max.     | 800 V              |
| Grid No.2 voltage         | $V_{g2o}$          | max.     | 800 V              |
|                           | $V_{g2}$           | max.     | 500 V              |
| Anode dissipation         |                    |          |                    |
|                           | at $V_i = 0$       | $W_a$    | max. 25 W          |
|                           | at $V_i > 0$       | $W_a$    | max. 27.5 W        |
| Grid No.2 dissipation     | $W_{g2}$           | max.     | 8 W                |
| Cathode current           | $I_k$              | max.     | 150 mA             |
| Grid No.1 resistor        |                    |          |                    |
|                           | for class A and AB | $R_{g1}$ | max. 0.7 $M\Omega$ |
|                           | for class B        | $R_{g1}$ | max. 0.5 $M\Omega$ |
| Cathode to heater voltage | $V_{kf}$           | max.     | 100 V              |

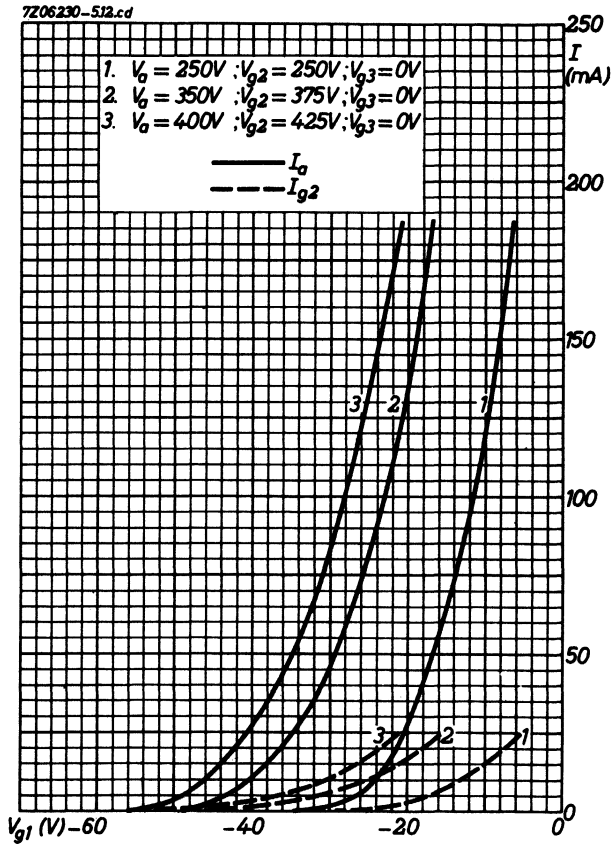

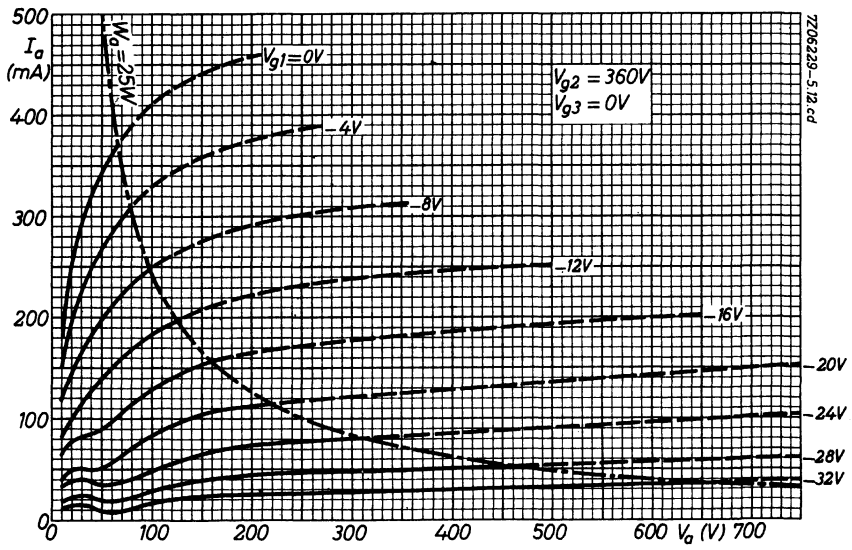
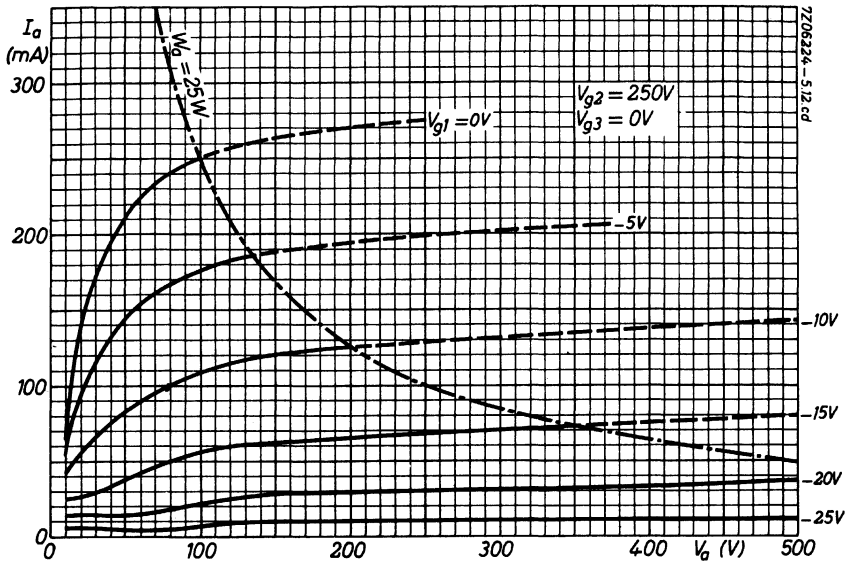

7206231-5.12.cd

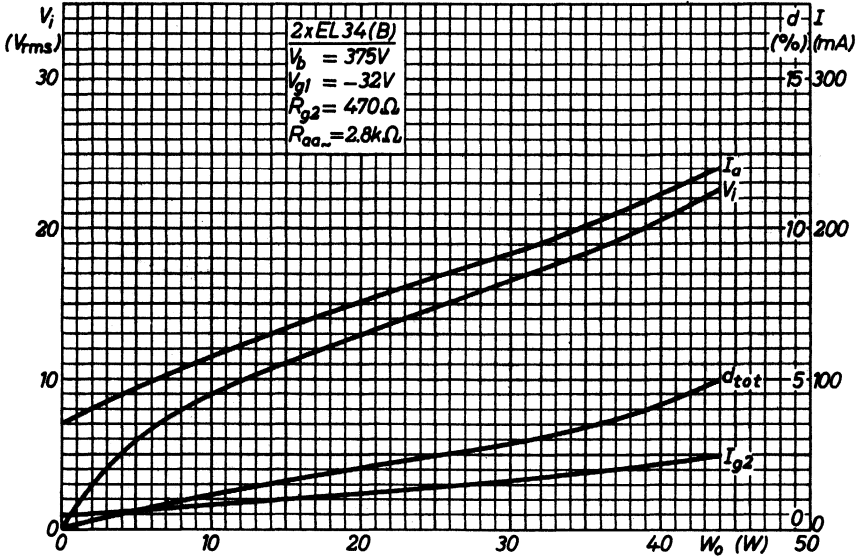

7206223-5.12.cd

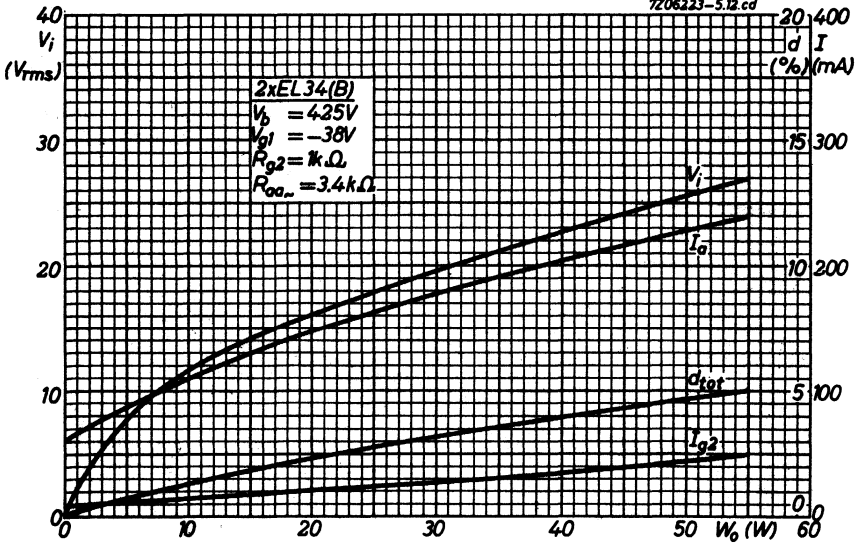

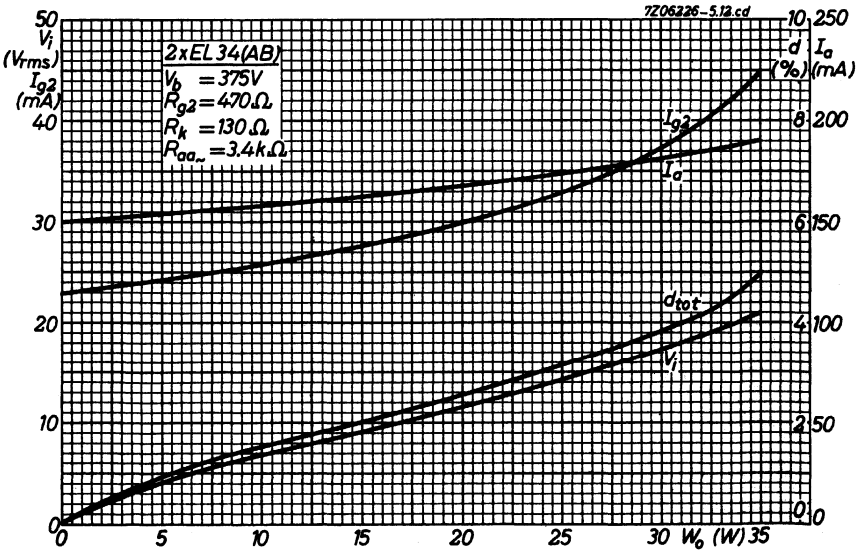
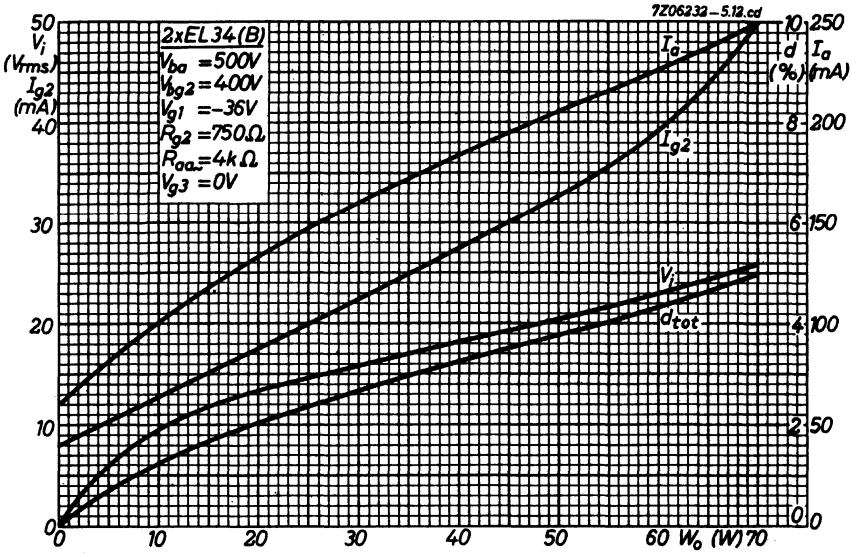

## LINE AND A.F. OUTPUT PENTODE

Pentode intended for use as line output tube in television receivers and as A.F. power amplifier.

**HEATING:** Indirectly by A.C. or D.C.; parallel supply

|                |       |      |   |
|----------------|-------|------|---|
| Heater voltage | $V_f$ | 6.3  | V |
| Heater current | $I_f$ | 1.25 | A |

### OPERATING CHARACTERISTICS

A.F. amplifier, Class B, two tubes in push pull

|                           |              |       |              |
|---------------------------|--------------|-------|--------------|
| Anode voltage             | $V_a$        | 300   | V            |
| Grid No.2 voltage         | $V_{g_2}$    | 150   | V            |
| Grid No.1 voltage         | $V_{g_1}$    | -29   | V            |
| Load resistance           | $R_{aa\sim}$ | 3.5   | $k\Omega$    |
| Grid No.1 driving voltage | $V_i$        | 0     | 20 $V_{RMS}$ |
| Anode current             | $I_a$        | 2x18  | 2x100 mA     |
| Grid No.2 current         | $I_{g_2}$    | 2x0.5 | 2x19 mA      |
| Output power              | $W_o$        | 0     | 44.5 W       |
| Distortion                | $d_{tot}$    | -     | 7.2 %        |

### LIMITING VALUES (Design centre rating system)

|                                     |          |      |       |
|-------------------------------------|----------|------|-------|
| Anode voltage                       | $V_a$    | max. | 250 V |
| Anode voltage for class B operation | $V_a$    | max. | 300 V |
| Cathode to heater voltage           | $V_{kf}$ | max. | 100 V |

-----  
 For further data and curves of this type  
 please refer to PL36  
 -----





**OPERATING CONDITIONS**

Stabilized circuits (D. C. feedback)

Cut-off voltage

The minimum required cut-off voltage ( $-V_{g1}$ ) during flyback is 120 V at  $V_a = 6000$  V,  $V_{g2} = 190$  V, and  $Z_{g1} = 1$  k $\Omega$  at line-frequency.

Supply-voltage: See page 5

Minimum required value of the screengrid voltage and of the anode voltage, when the tube is used in a line output stage.

The graphs refer to nominal mains voltage provided the specified values of  $I_a$  at  $V_a$  min, will be available throughout life of the tube at supply voltage values 10% below nominal.

In order to prevent Barkhausen interferences and less of stabilisation, care should be taken that the anode voltage never drops below the specified  $V_a$  min. during the scanning period.

**OPERATING CHARACTERISTICS** as class B push-pull A. F. power amplifier, two tubes.

|                                   |           |            |              |            |
|-----------------------------------|-----------|------------|--------------|------------|
| Anode voltage                     | $V_a$     | 170        | 200          | V          |
| Grid No. 3 voltage                | $V_{g3}$  | 0          | 0            | V          |
| Grid No. 2 supply voltage         | $V_{bg2}$ | 170        | 200          | V          |
| Common Grid No. 2 series resistor | $R_{g2}$  | 1          | 1            | k $\Omega$ |
| Grid No. 1 voltage                | $V_{g1}$  | -27        | -31.5        | V          |
| Load resistance                   | $R_{aa}$  | 2.5        | 2.5          | k $\Omega$ |
| Grid No. 1 driving voltage        | $V_i$     | 0 16.5     | 0 21.5       | $V_{RMS}$  |
| Anode current                     | $I_a$     | 2x25 2x72  | 2x27 2x84    | mA         |
| Grid No. 2 current                | $I_{g2}$  | 2x1.5 2x10 | 2x2.0 2x11.0 | mA         |
| Output power                      | $W_o$     | 0 13.0     | 0 20         | W          |
| Distortion                        | $d_{tot}$ | - 5.2      | - 6.5        | %          |

**LIMITING VALUES** (Design centre rating system)

|                               |                        |                       |                  |
|-------------------------------|------------------------|-----------------------|------------------|
| Anode voltage                 | $V_{a0}$               | max. 550              | V                |
|                               | $V_a$                  | max. 250              | V                |
| Anode voltage, peak           | $V_{ap}$               | max. 7                | kV <sup>1)</sup> |
| negative peak                 | $-V_{ap}$              | max. 7                | kV <sup>1)</sup> |
| Anode dissipation             | $W_a$                  | } See figure<br>below |                  |
| Grid No.2 dissipation         | $W_{g2}$ <sup>2)</sup> |                       |                  |
| Anode + grid No.2 dissipation | $W_a + W_{g2}$         |                       |                  |
| Grid No.2 voltage             | $V_{g20}$              | max. 550              | V                |
|                               | $V_{g2}$               | max. 250              | V                |
| Cathode current               | $I_k$                  | max. 180              | mA               |
| Cathode to heater voltage     | $V_{kf}$               | max. 100              | V                |
| Grid No.1 resistor            | $R_{g1}$               | max. 0.5              | MΩ               |

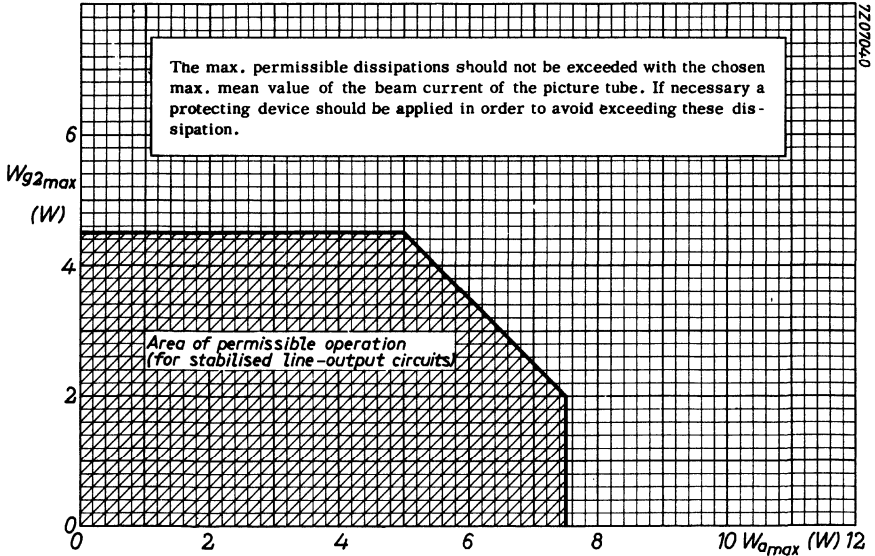

1) Maximum pulse duration 22% of a cycle but maximum 18 μs.

2) During the heating-up of the cathode  $W_{g2} = \text{max. } 6 \text{ W}$ .

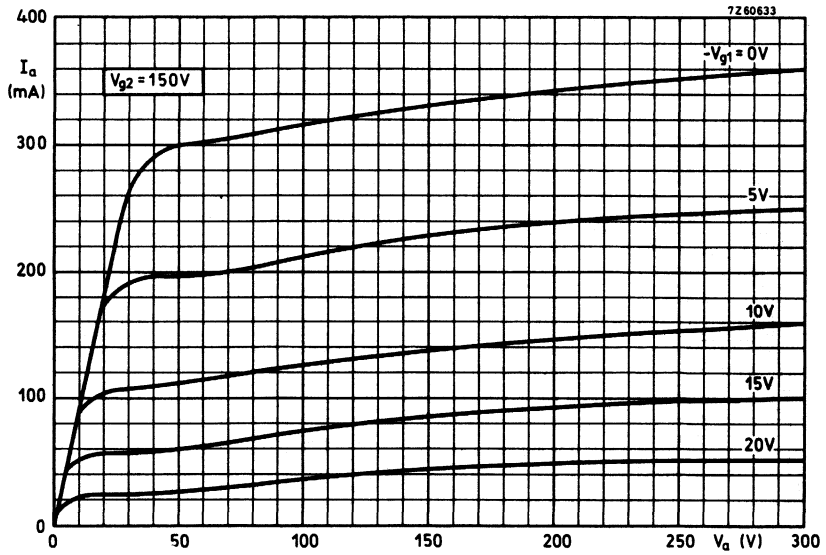
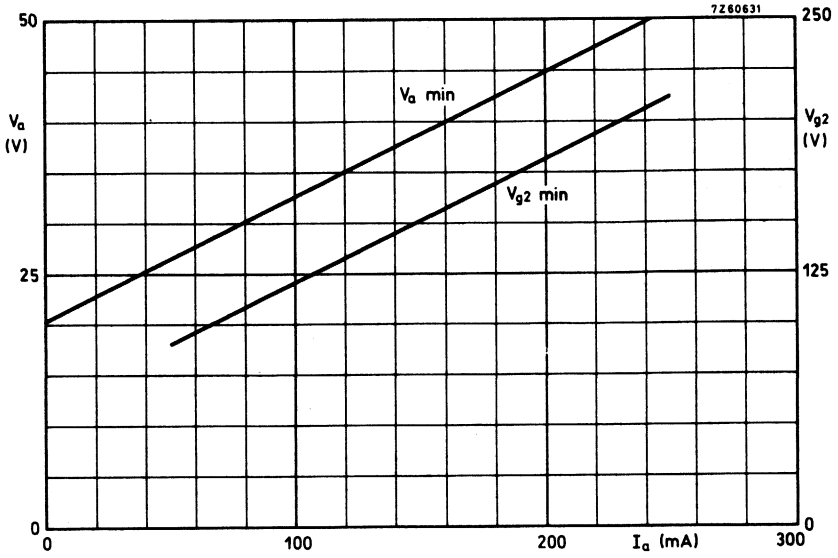

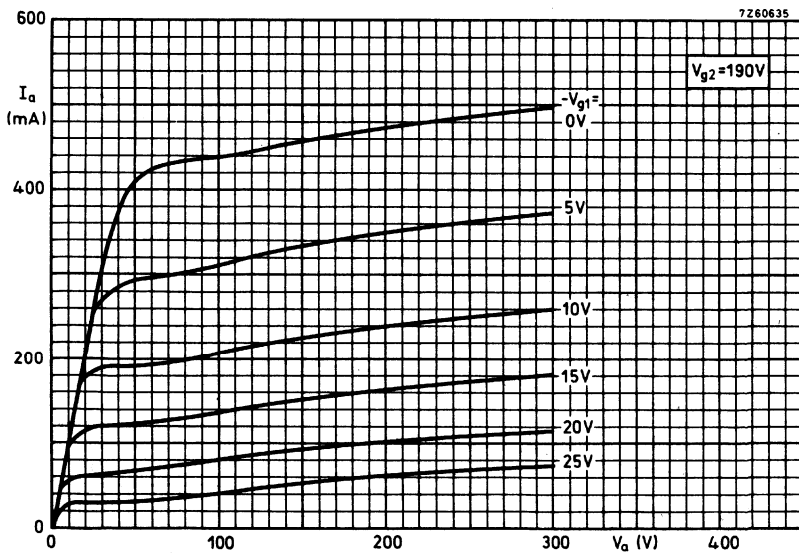
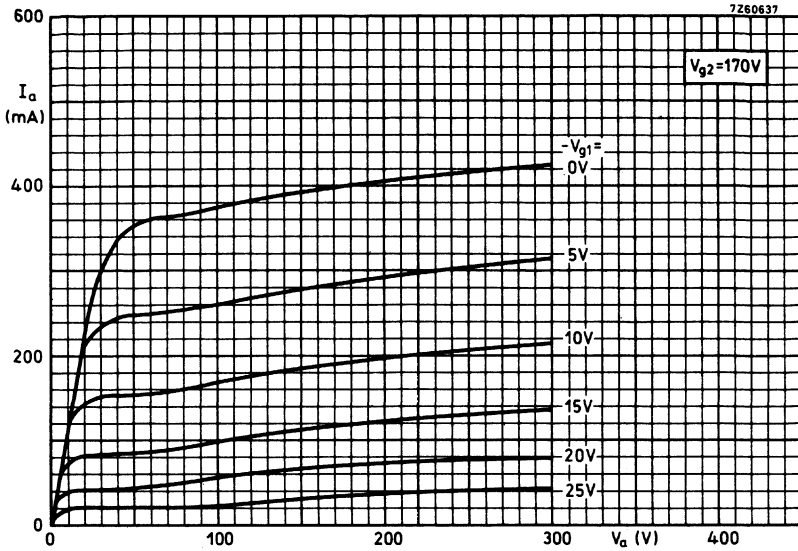

## A.F. OUTPUT PENTODE

Pentode intended for use as A.F. power amplifier.

| QUICK REFERENCE DATA |               |           |
|----------------------|---------------|-----------|
| Anode current        | $I_a$         | 48 mA     |
| Transconductance     | $S$           | 11.3 mA/V |
| Amplification factor | $\mu g_2 g_1$ | 19        |
| Output power         | $W_o$         | 6.0 W     |

**HEATING:** Indirect by A.C. or D.C.; parallel supply

|                |       |        |
|----------------|-------|--------|
| Heater voltage | $V_f$ | 6.3 V  |
| Heater current | $I_f$ | 760 mA |

### DIMENSIONS AND CONNECTIONS

Dimensions in mm

Base: Noval

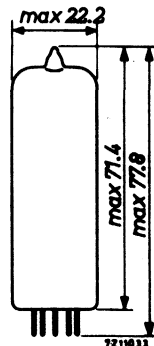
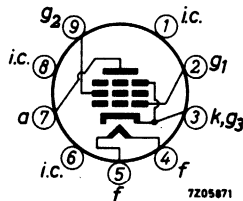

### CAPACITANCES

|                               |              |              |
|-------------------------------|--------------|--------------|
| Anode to all except grid No.1 | $C_a(g_1)$   | 6.5 pF       |
| Grid No.1 to all except anode | $C_{g_1(a)}$ | 10.8 pF      |
| Anode to grid No.1            | $C_{ag_1}$   | max. 0.5 pF  |
| Grid No.1 to heater           | $C_{g_1f}$   | max. 0.25 pF |

**OPERATING CHARACTERISTICS**

Class A

|                           |                         |      |      |     |      |                             |
|---------------------------|-------------------------|------|------|-----|------|-----------------------------|
| Anode voltage             | $V_a$                   |      | 250  |     |      | V                           |
| Grid No.2 voltage         | $V_{g2}$                |      | 250  |     |      | V                           |
| Grid No.1 voltage         | $V_{g1}$                |      | -7.3 |     |      | V                           |
| Cathode resistor          | $R_K$                   |      | 135  |     |      | $\Omega$                    |
| Load resistance           | $R_{a\sim}$             |      | 5.2  |     |      | $k\Omega$                   |
| Grid No.1 driving voltage | $V_i$                   | 0    | 0.3  | 3.4 | 4.3  | 4.7 <sup>2)</sup> $V_{RMS}$ |
| Anode current             | $I_a$                   | 48   | -    | -   | 49.5 | 49.2 mA                     |
| Grid No.2 current         | $I_{g2}$                | 5.5  | -    | -   | 10.8 | 11.6 mA                     |
| Transconductance          | $S$                     | 11.3 | -    | -   | -    | - mA/V                      |
| Amplification factor      | $\mu_{g2g1}$            | 19   | -    | -   | -    | -                           |
| Internal resistance       | $R_i$                   | 38   | -    | -   | -    | - $k\Omega$                 |
| Output power              | $W_o$ <sup>1)</sup>     | 0    | 0.05 | 4.5 | 5.7  | 6.0 W                       |
| Distortion, total         | $d_{tot}$ <sup>1)</sup> | -    | -    | 6.8 | 10   | - %                         |
| second harmonic           | $d_2$ <sup>1)</sup>     | -    | -    | 3.0 | 2.0  | - %                         |
| third harmonic            | $d_3$ <sup>1)</sup>     | -    | -    | 5.8 | 9.5  | - %                         |
| Anode voltage             | $V_a$                   |      | 250  |     |      | V                           |
| Grid No.2 voltage         | $V_{g2}$                |      | 250  |     |      | V                           |
| Grid No.1 voltage         | $V_{g1}$                |      | -7.3 |     |      | V                           |
| Cathode resistor          | $R_K$                   |      | 135  |     |      | $\Omega$                    |
| Load resistance           | $R_{a\sim}$             |      | 4.5  |     |      | $k\Omega$                   |
| Grid No.1 driving voltage | $V_i$                   | 0    | 0.3  | 3.5 | 4.4  | 4.8 <sup>2)</sup> $V_{RMS}$ |
| Anode current             | $I_a$                   | 48   | -    | -   | 50.6 | 50.5 mA                     |
| Grid No.2 current         | $I_{g2}$                | 5.5  | -    | -   | 10   | 11 mA                       |
| Transconductance          | $S$                     | 11.3 | -    | -   | -    | - mA/V                      |
| Amplification factor      | $\mu_{g2g1}$            | 19   | -    | -   | -    | -                           |
| Internal resistance       | $R_i$                   | 38   | -    | -   | -    | - $k\Omega$                 |
| Output power              | $W_o$ <sup>1)</sup>     | 0    | 0.05 | 4.5 | 5.7  | 6.0 W                       |
| Distortion, total         | $d_{tot}$ <sup>1)</sup> | -    | -    | 7.5 | 10   | - %                         |
| second harmonic           | $d_2$ <sup>1)</sup>     | -    | -    | 5.7 | 5.0  | - %                         |
| third harmonic            | $d_3$ <sup>1)</sup>     | -    | -    | 4.5 | 8    | - %                         |

1) Measured with fixed bias

2) At  $I_{g1} = +0.3 \mu A$

## OPERATING CHARACTERISTICS (continued)

## Class A (continued)

|                           |                         |      |      |      |                  |
|---------------------------|-------------------------|------|------|------|------------------|
| Anode voltage             | $V_a$                   | 250  |      |      | V                |
| Grid No.2 voltage         | $V_{g2}$                | 250  |      |      | V                |
| Grid No.1 voltage         | $V_{g1}$                | -8.4 |      |      | V                |
| Cathode resistor          | $R_k$                   | 210  |      |      | $\Omega$         |
| Load resistance           | $R_{a\sim}$             | 7    |      |      | $k\Omega$        |
| Grid No.1 driving voltage | $V_i$                   | 0    | 0.3  | 3.5  | $5.5^2) V_{RMS}$ |
| Anode current             | $I_a$                   | 36   | -    | 36.8 | 36 mA            |
| Grid No.2 current         | $I_{g2}$                | 4.1  | -    | 8.5  | 14.6 mA          |
| Transconductance          | $S$                     | 10   | -    | -    | mA/V             |
| Amplification factor      | $\mu_{g2g1}$            | 19   | -    | -    | -                |
| Internal resistance       | $R_i$                   | 40   | -    | -    | $k\Omega$        |
| Output power              | $W_o$ <sup>1)</sup>     | 0    | 0.05 | 4.2  | 5.6 W            |
| Distortion, total         | $d_{tot}$ <sup>1)</sup> | -    | -    | 10   | - %              |
| second harmonic           | $d_2$ <sup>1)</sup>     | -    | -    | 1.7  | - %              |
| third harmonic            | $d_3$ <sup>1)</sup>     | -    | -    | 8.7  | - %              |

|                           |                         |      |      |      |                  |
|---------------------------|-------------------------|------|------|------|------------------|
| Anode voltage             | $V_a$                   | 250  |      |      | V                |
| Grid No.2 voltage         | $V_{g2}$                | 210  |      |      | V                |
| Grid No.1 voltage         | $V_{g1}$                | -6.4 |      |      | V                |
| Cathode resistor          | $R_k$                   | 160  |      |      | $\Omega$         |
| Load resistance           | $R_{a\sim}$             | 7    |      |      | $k\Omega$        |
| Grid No.1 driving voltage | $V_i$                   | 0    | 0.3  | 3.4  | $3.8^2) V_{RMS}$ |
| Anode current             | $I_a$                   | 36   | -    | 36.6 | 36.5 mA          |
| Grid No.2 current         | $I_{g2}$                | 3.9  | -    | 7.3  | 8.0 mA           |
| Transconductance          | $S$                     | 10.4 | -    | -    | mA/V             |
| Amplification factor      | $\mu_{g2g1}$            | 19   | -    | -    | -                |
| Internal resistance       | $R_i$                   | 40   | -    | -    | $k\Omega$        |
| Output power              | $W_o$ <sup>1)</sup>     | 0    | 0.05 | 4.3  | 4.7 W            |
| Distortion, total         | $d_{tot}$ <sup>1)</sup> | -    | -    | 10   | - %              |
| second harmonic           | $d_2$ <sup>1)</sup>     | -    | -    | 1.8  | - %              |
| third harmonic            | $d_3$ <sup>1)</sup>     | -    | -    | 9.3  | - %              |

1) Measured with fixed bias

2) At  $I_{g1} = +0.3 \mu A$

**OPERATING CHARACTERISTICS (continued)**

Class B, two tubes in push-pull

|                           |              |       |        |           |      |           |
|---------------------------|--------------|-------|--------|-----------|------|-----------|
| Anode voltage             | $V_a$        | 250   | 300    | V         |      |           |
| Grid No.2 voltage         | $V_{g_2}$    | 250   | 300    | V         |      |           |
| Grid No.1 voltage         | $V_{g_1}$    | -11.6 | -14.7  | V         |      |           |
| Load resistance           | $R_{aa\sim}$ | 8     | 8      | $k\Omega$ |      |           |
| Grid No.1 driving voltage | $V_i$        | 0     | 8      | 0         | 10   | $V_{RMS}$ |
| Anode current             | $I_a$        | 2x10  | 2x37.5 | 2x7.5     | 2x46 | mA        |
| Grid No.2 current         | $I_{g_2}$    | 2x1.1 | 2x7.5  | 2x0.8     | 2x11 | mA        |
| Output power              | $W_o$        | 0     | 11     | 0         | 17   | W         |
| Distortion                | $d_{tot}$    | -     | 3      | -         | 4    | %         |

Class AB, two tubes in push-pull

|                           |              |       |        |           |      |           |
|---------------------------|--------------|-------|--------|-----------|------|-----------|
| Anode voltage             | $V_a$        | 250   | 300    | V         |      |           |
| Grid No.2 voltage         | $V_{g_2}$    | 250   | 300    | V         |      |           |
| Common cathode resistor   | $R_k$        | 130   | 130    | $\Omega$  |      |           |
| Load resistance           | $R_{aa\sim}$ | 8     | 8      | $k\Omega$ |      |           |
| Grid No.1 driving voltage | $V_i$        | 0     | 8      | 0         | 10   | $V_{RMS}$ |
| Anode current             | $I_a$        | 2x31  | 2x37.5 | 2x36      | 2x46 | mA        |
| Grid No.2 current         | $I_{g_2}$    | 2x3.5 | 2x7.5  | 2x4       | 2x11 | mA        |
| Output power              | $W_o$        | 0     | 11     | 0         | 17   | W         |
| Distortion                | $d_{tot}$    | -     | 3      | -         | 4    | %         |



**OPERATING CHARACTERISTICS IN TRIODE CONNECTION**

( $g_2$  connected to a)

Class A

|                           |             |     |      |      |           |
|---------------------------|-------------|-----|------|------|-----------|
| Anode voltage             | $V_a$       | 250 |      |      | V         |
| Cathode resistor          | $R_k$       | 270 |      |      | $\Omega$  |
| Load resistance           | $R_{a\sim}$ | 3.5 |      |      | $k\Omega$ |
| Grid No.1 driving voltage | $V_i$       | 0   | 1.0  | 6.7  | $V_{RMS}$ |
| Anode current             | $I_a$       | 34  | -    | 36   | mA        |
| Output power              | $W_o$       | -   | 0.05 | 1.95 | W         |
| Distortion                | $d_{tot}$   | -   | -    | 9    | %         |

Class AB, two tubes in push-pull

|   |              |      |        |      |              |
|---|--------------|------|--------|------|--------------|
| Anode voltage                               | $V_a$        | 250  | 300    |      | V            |
| Common cathode resistor                     | $R_k$        | 270  | 270    |      | $\Omega$     |
| Load resistance                             | $R_{aa\sim}$ | 10   | 10     |      | $k\Omega$    |
| Grid No.1 driving voltage                   | $V_i$        | 0    | 8.3    | 0    | 10 $V_{RMS}$ |
| Anode current                               | $I_a$        | 2x20 | 2x21.7 | 2x24 | 2x26 mA      |
| Output power                                | $W_o$        | 0    | 3.4    | 0    | 5.2 W        |
| Distortion                                  | $d_{tot}$    | -    | 2.5    | -    | 2.5 %        |
| Grid No.1 driving voltage for $W_o = 50$ mW | $V_i$        | 0.95 |        | 0.9  | $V_{RMS}$    |

**LIMITING VALUES** (Design centre rating system)

|                           |            |      |                     |
|---------------------------|------------|------|---------------------|
| Anode voltage             | $V_{a_0}$  | max. | 550 V               |
|                           | $V_a$      | max. | 300 V <sup>1)</sup> |
| Anode dissipation         | $W_a$      | max. | 12 W <sup>1)</sup>  |
| Grid No.2 voltage         | $V_{g2_0}$ | max. | 550 V               |
|                           | $V_{g2}$   | max. | 300 V <sup>1)</sup> |
| Grid No.2 dissipation     | $W_{g2}$   | max. | 2 W                 |
|                           | $W_{g2p}$  | max. | 4 W                 |
| Grid No.1 voltage         | $-V_{g1}$  | max. | 100 V               |
| Cathode current           | $I_k$      | max. | 65 mA               |
| Grid No.1 resistor        |            |      |                     |
| for automatic bias        | $R_{g1}$   | max. | 1 M $\Omega$        |
| for fixed bias            | $R_{g1}$   | max. | 0.3 M $\Omega$      |
| Cathode to heater voltage | $V_{kf}$   | max. | 100 V               |

<sup>1)</sup> When the heater and positive voltages are obtained from a storage battery by means of a vibrator, the max. values of  $V_a$  and  $V_{g2}$  are 250 V and that of  $W_a$  is 9 W.

7206277-5,12,hd

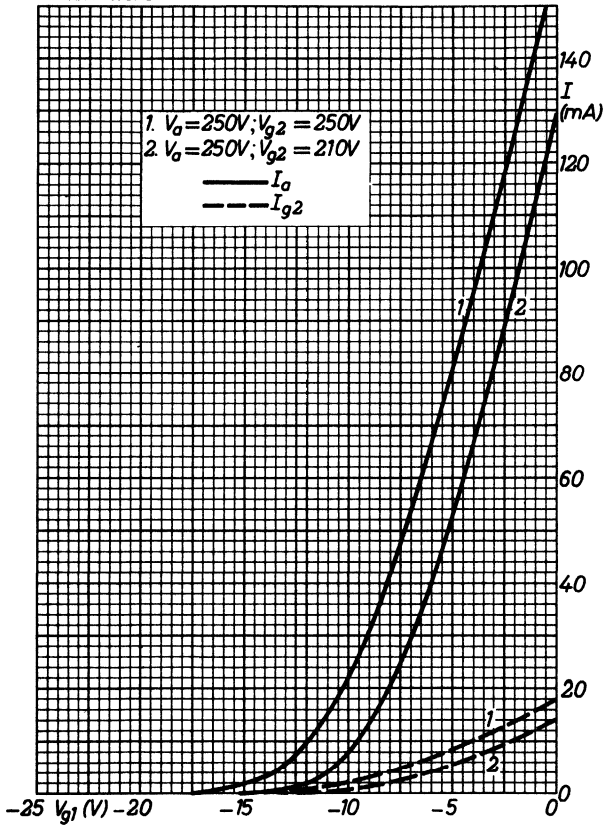

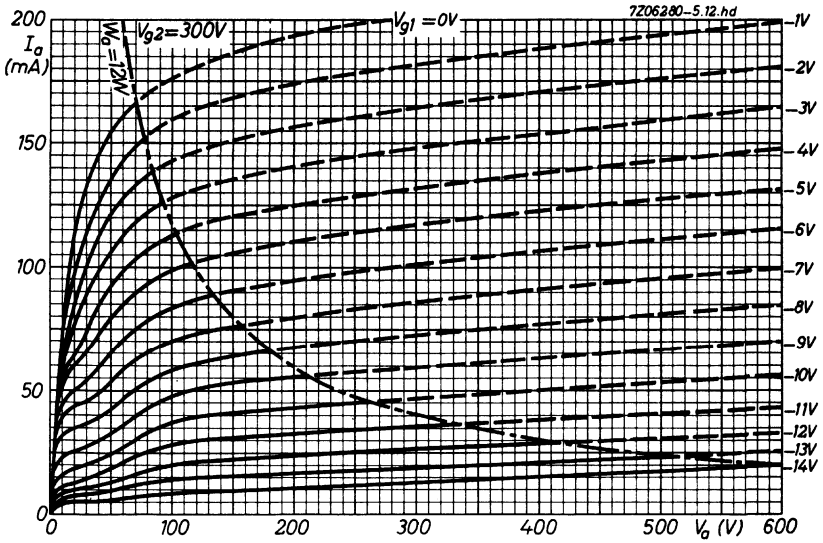
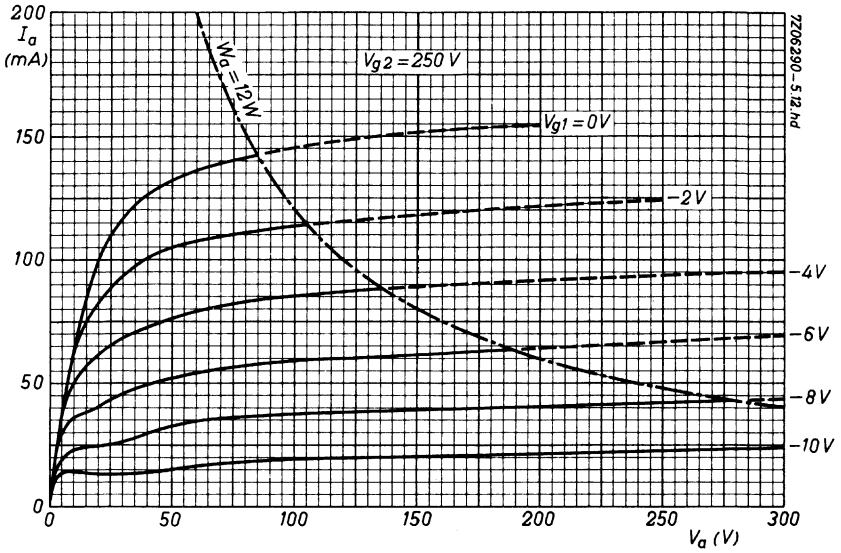

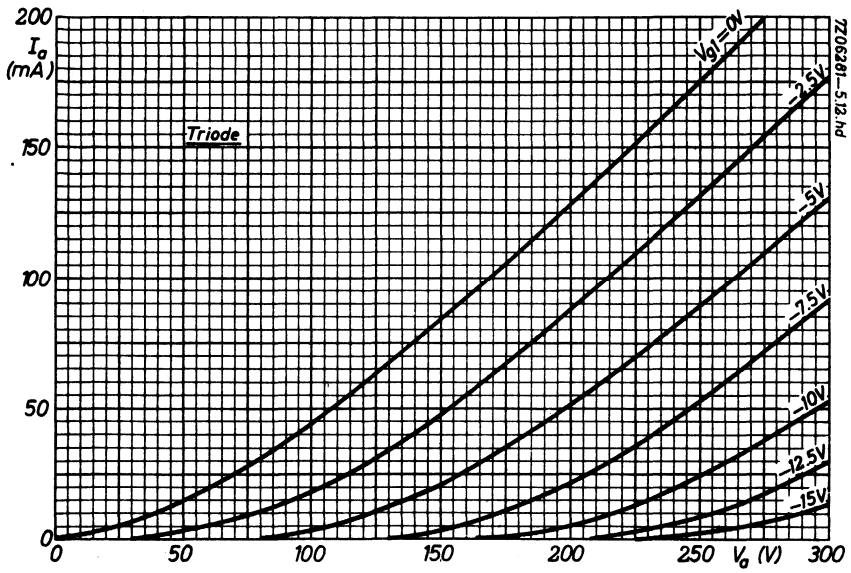

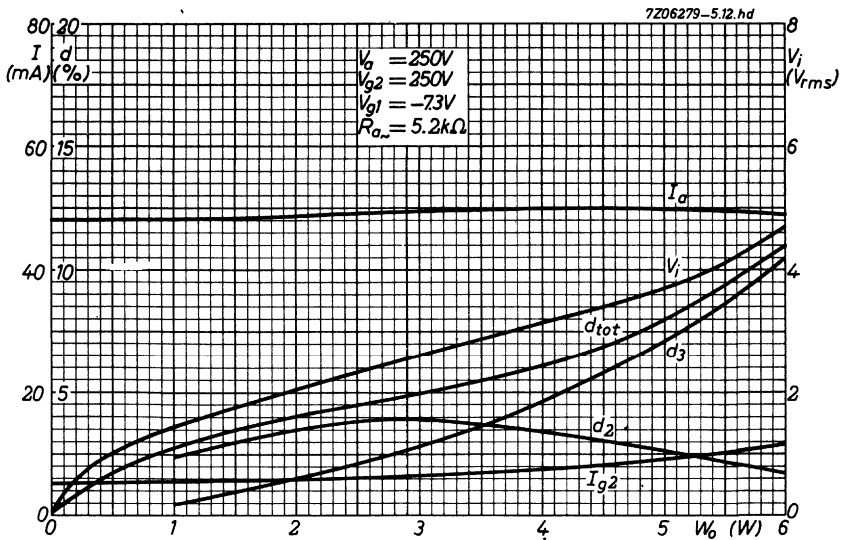
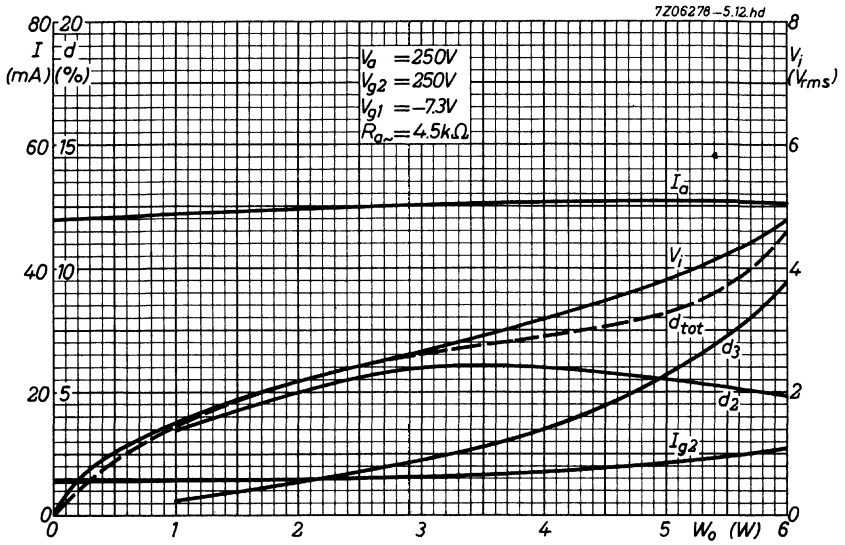

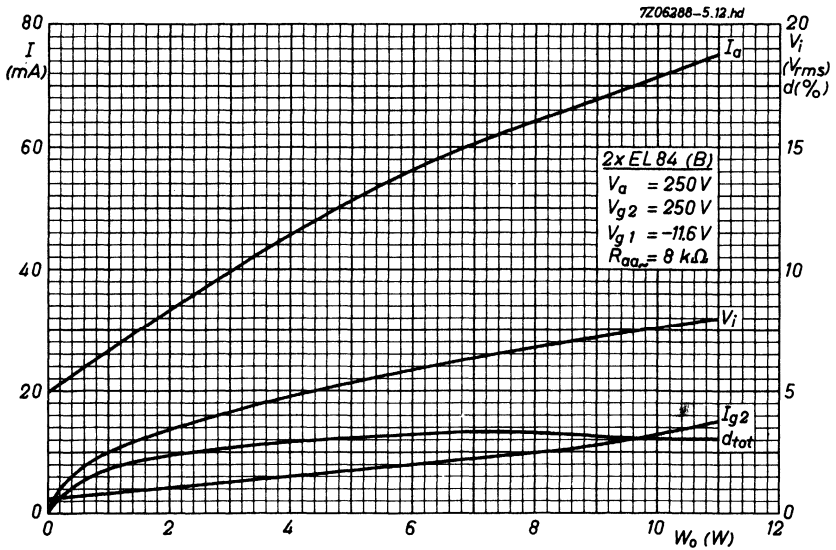
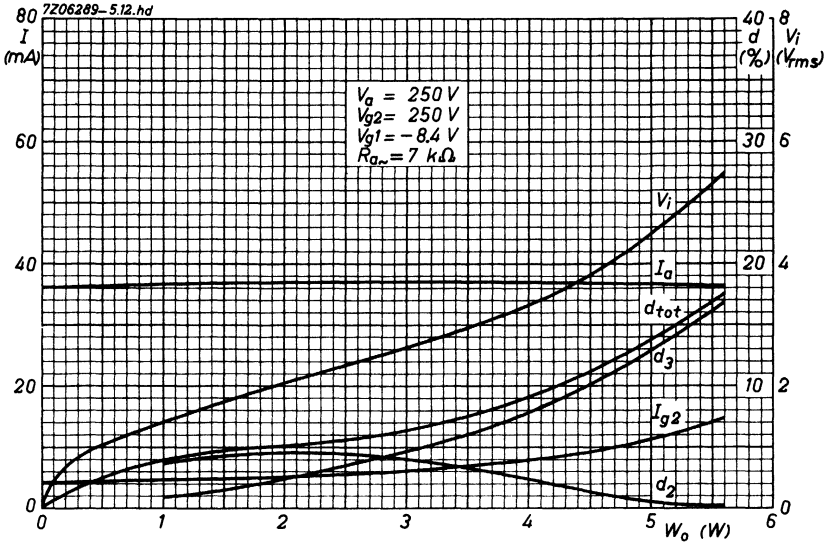

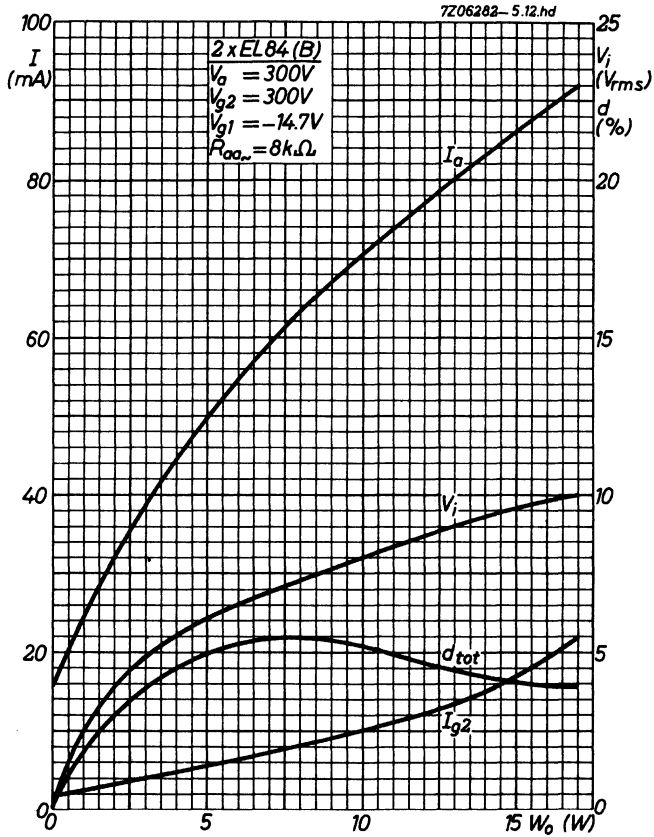



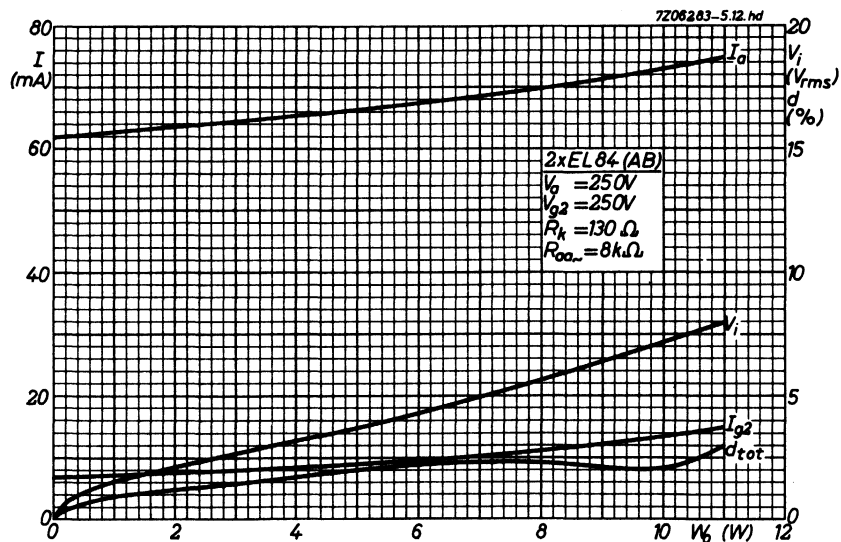

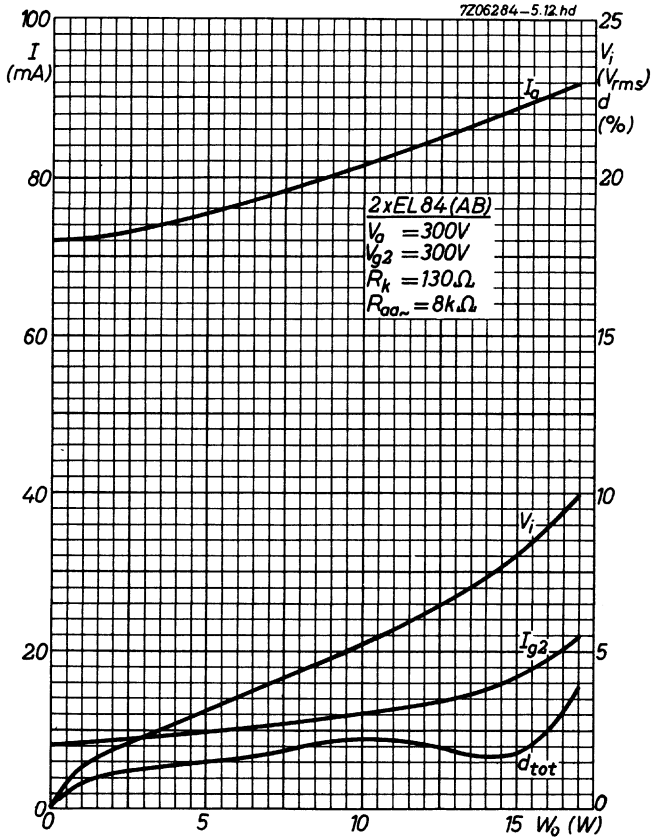

## FRAME AND A.F. OUTPUT PENTODE

Pentode intended for use as frame output tube in television receivers and as A.F. power amplifier.

| QUICK REFERENCE DATA |          |      |        |
|----------------------|----------|------|--------|
| Anode peak voltage   | $V_{ap}$ | max. | 2 kV   |
| Cathode current      | $I_k$    | max. | 100 mA |
| Output power         | $W_o$    |      | 5.3 W  |

**HEATING:** Indirect by A.C. or D.C.; parallel supply

Heater voltage

$V_f$  6.3 V

Heater current

$I_f$  760 mA

### DIMENSIONS AND CONNECTIONS

Base: Noval

Dimensions in mm

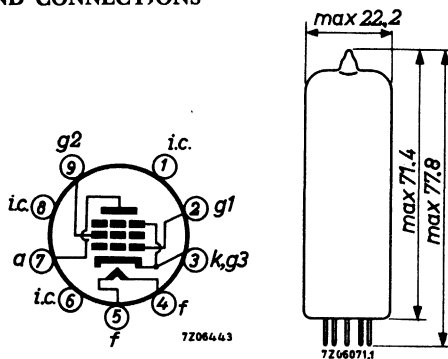

### CAPACITANCES

Anode to all except grid No.1

$C_{a(g_1)}$  6.8 pF

Grid No.1 to all except anode

$C_{g_1(a)}$  13 pF

Anode to grid No.1

$C_{ag_1}$  max. 0.6 pF

Grid No.1 to heater

$C_{g_1f}$  max. 0.25 pF

**OPTIMUM PEAK ANODE CURRENT IN FRAME OUTPUT OPERATION**

The circuit should be designed so that the peak anode current does not exceed:

- 145 mA at  $V_a = 60$  V,  $V_{g2} = 170$  V,  $V_f = 6.3$  V
- 190 mA at  $V_a = 70$  V,  $V_{g2} = 200$  V,  $V_f = 6.3$  V
- 220 mA at  $V_a = 80$  V,  $V_{g2} = 220$  V,  $V_f = 6.3$  V

The minimum available value of the peak anode current at end of life and  $V_f = 5.7$  V is:

- 125 mA at  $V_a = 60$  V,  $V_{g2} = 170$  V
- 160 mA at  $V_a = 70$  V,  $V_{g2} = 200$  V
- 185 mA at  $V_a = 80$  V,  $V_{g2} = 220$  V

**OPERATING CHARACTERISTICS**

A.F. power amplifier, class A

(Measured with  $V_k$  constant)

|   |             |            |           |
|---|-------------|------------|-----------|
| Supply voltage                            | $V_b$       | 200        | V         |
| Grid No.2 series resistor (non decoupled) | $R_{g2}$    | 470        | $\Omega$  |
| Cathode resistor                          | $R_k$       | 215        | $\Omega$  |
| Load resistance                           | $R_{a\sim}$ | 2.5        | $k\Omega$ |
| Grid No.1 driving voltage                 | $V_i$       | 0 0.52 7.0 | $V_{RMS}$ |
| Anode current                             | $I_a$       | 65 - 64    | mA        |
| Grid No.2 current                         | $I_{g2}$    | 3.2 - 11.4 | mA        |
| Output power                              | $W_o$       | 0 0.05 5.3 | W         |
| Distortion                                | $dt_{tot}$  | - - 10     | %         |

A.F. power amplifier, class AB, two tubes in push-pull

|                           |              |              |           |
|---------------------------|--------------|--------------|-----------|
| Anode supply voltage      | $V_{ba}$     | 250          | V         |
| Grid No.2 supply voltage  | $V_{bg2}$    | 200          | V         |
| Common cathode resistor   | $R_k$        | 150          | $\Omega$  |
| Load resistance           | $R_{aa\sim}$ | 5.5          | $k\Omega$ |
| Grid No.1 driving voltage | $V_i$        | 0 0.37 13.0  | $V_{RMS}$ |
| Anode current             | $I_a$        | 2x50 - 2x55  | mA        |
| Grid No.2 current         | $I_{g2}$     | 2x2.0 - 2x13 | mA        |
| Output power              | $W_o$        | 0 0.05 18.5  | W         |
| Distortion                | $dt_{tot}$   | - - 4.5      | %         |

**OPERATING CHARACTERISTICS (continued)**

A.F. power amplifier, single ended push-pull

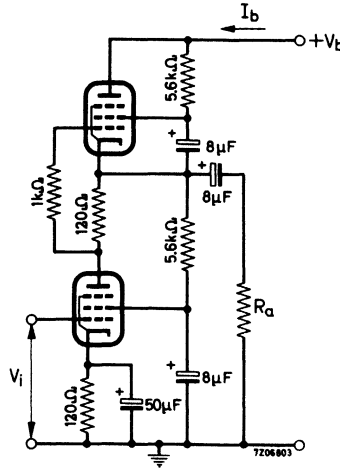

a) Single tone input signal

|                           |             |            |            |
|---------------------------|-------------|------------|------------|
| Supply voltage            | $V_b$       | 300        | V          |
| Load resistance           | $R_{a\sim}$ | 1          | k $\Omega$ |
| Grid No.1 driving voltage | $V_i$       | 0 0.41 5.4 | $V_{RMS}$  |
| Supply current            | $I_b$       | 66 - 64    | mA         |
| Output power              | $W_o$       | 0 0.05 4.5 | W          |
| Distortion                | $d_{tot}$   | - - 9.3    | %          |

b) Double tone input signal

|                           |             |       |                |
|---------------------------|-------------|-------|----------------|
| Supply voltage            | $V_b$       | 300   | V              |
| Load resistance           | $R_{a\sim}$ | 1     | k $\Omega$     |
| Grid No.1 driving voltage | $V_i$       | 0 2.7 | $V_{RMS}^{1)}$ |
| Supply current            | $I_b$       | 66 64 | mA             |
| Output power              | $W_o$       | 0 5.5 | W              |
| Distortion                | $d_{tot}$   | - 8.5 | %              |

1) Value of each tone separately.

**REMARK**

Single tone data are obtained with a pure sinusoidal input voltage. However such an input voltage is in general not representative for the reproduction of music and speech, since a purely sinusoidal tone seldom occurs.

The double tone data are obtained with two sinusoidal signals of different frequencies but of the same amplitude. This appears to be far better in agreement with practice. In the case of full drive with two sinusoidal signals different in frequency but having the same amplitude, the output power is half the value obtained at full drive with a single sinusoidal input voltage of twice this amplitude. To make comparison possible the obtained output power with double tone has therefore been multiplied by 2.

**LIMITING VALUES** (Design centre rating system)

|   |              |      |                    |
|---|--------------|------|--------------------|
| Anode voltage                                   | $V_{a_o}$    | max. | 550 V              |
|   | $V_a$        | max. | 250 V              |
| Anode peak voltage                              | $V_{a_p}$    | max. | 2 kV <sup>1)</sup> |
| Grid No.2 voltage                               | $V_{g_{2o}}$ | max. | 550 V              |
|   | $V_{g_2}$    | max. | 250 V              |
| Anode dissipation                               | $W_a$        | max. | 12 W <sup>2)</sup> |
| Grid No.2 dissipation:                          |              |      |                    |
| average   | $W_{g_2}$    | max. | 1.75 W             |
| peak  | $W_{g_{2p}}$ | max. | 6 W                |
| Cathode current                                 | $I_k$        | max. | 100 mA             |
| Grid No.1 resistor:                             |              |      |                    |
| automatic bias                                  | $R_{g_1}$    | max. | 1 M $\Omega$       |
| frame output application<br>with automatic bias | $R_{g_1}$    | max. | 2 M $\Omega$       |
| Cathode to heater voltage                       | $V_{kf}$     | max. | 200 V              |

<sup>1)</sup> Valid for application in frame output circuits where the max. pulse duration is 4% of a cycle with a max. of 0.8 ms.

<sup>2)</sup> For frame output application  $W_a = \text{max. } 10 \text{ W}$ .

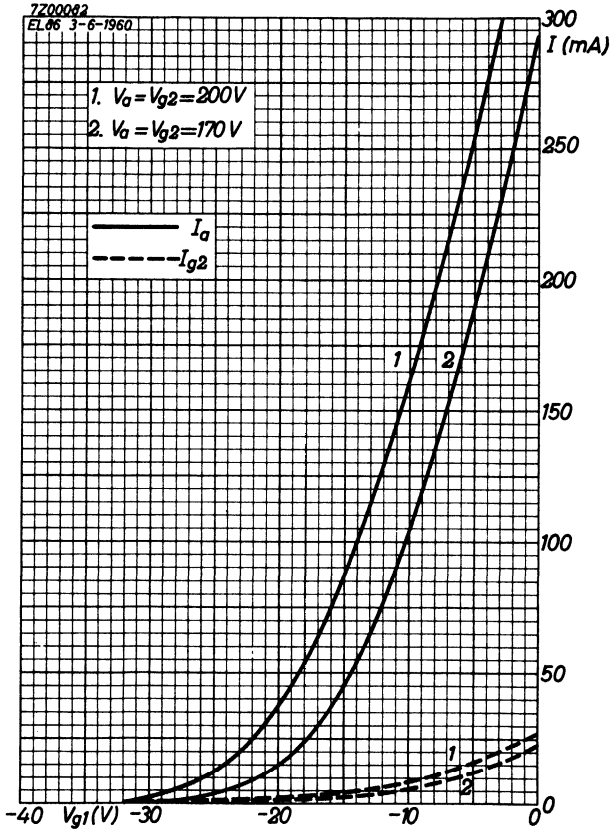

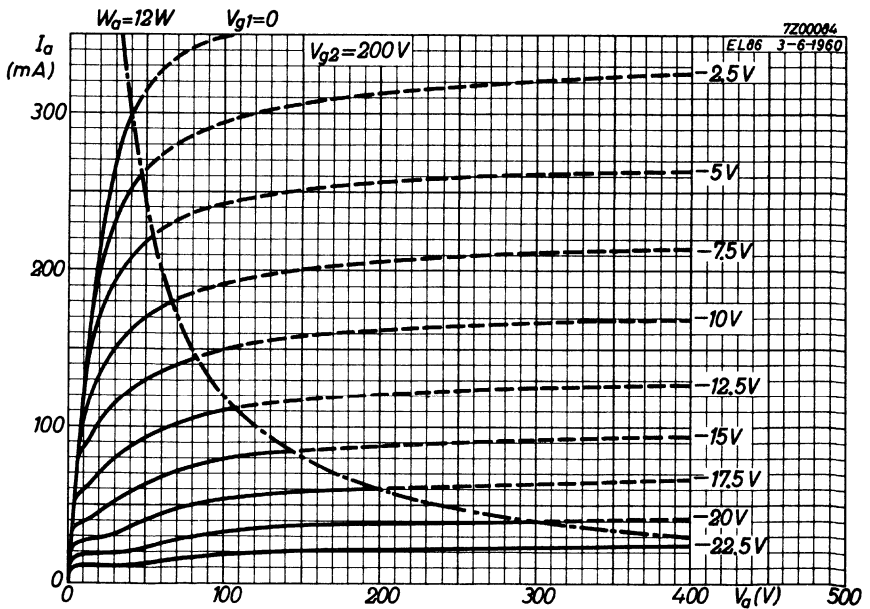
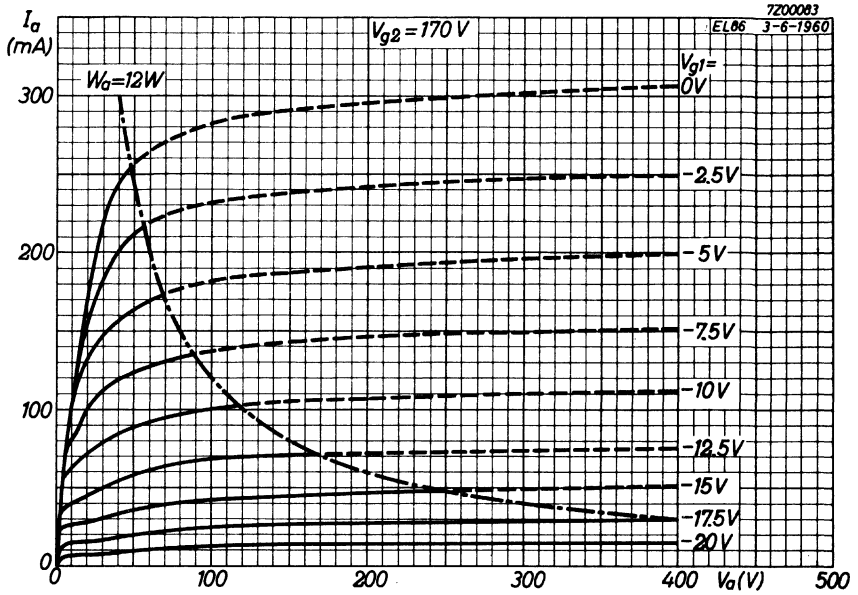



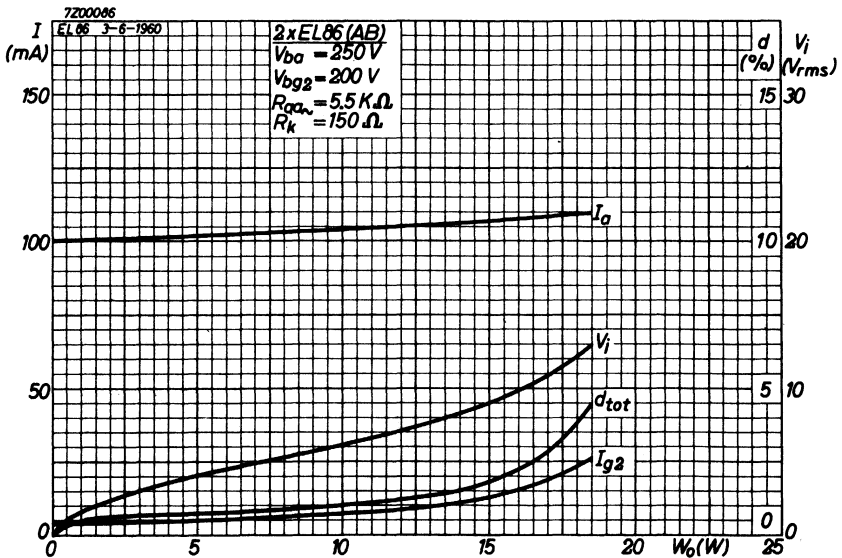
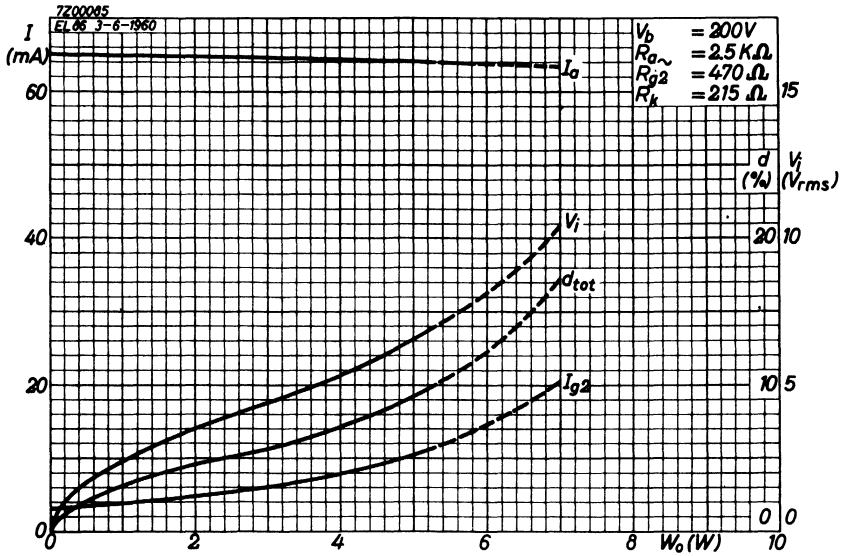

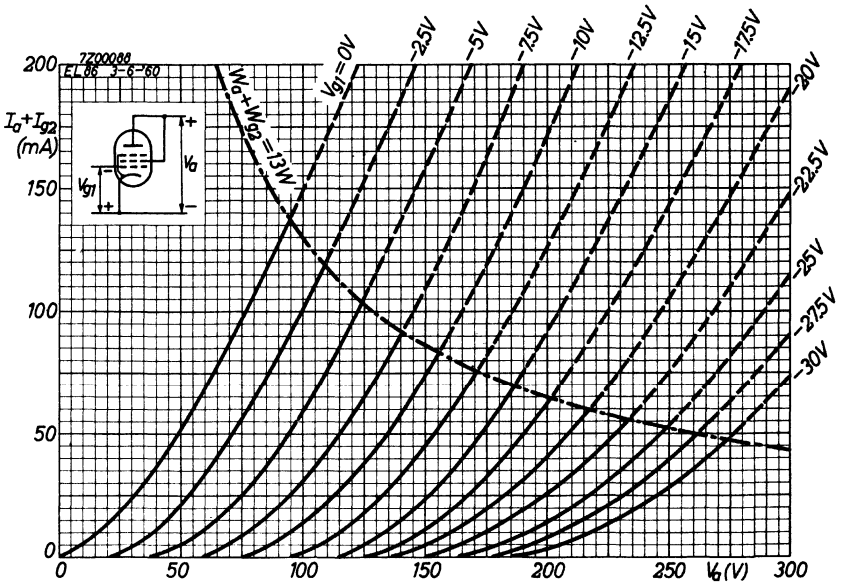
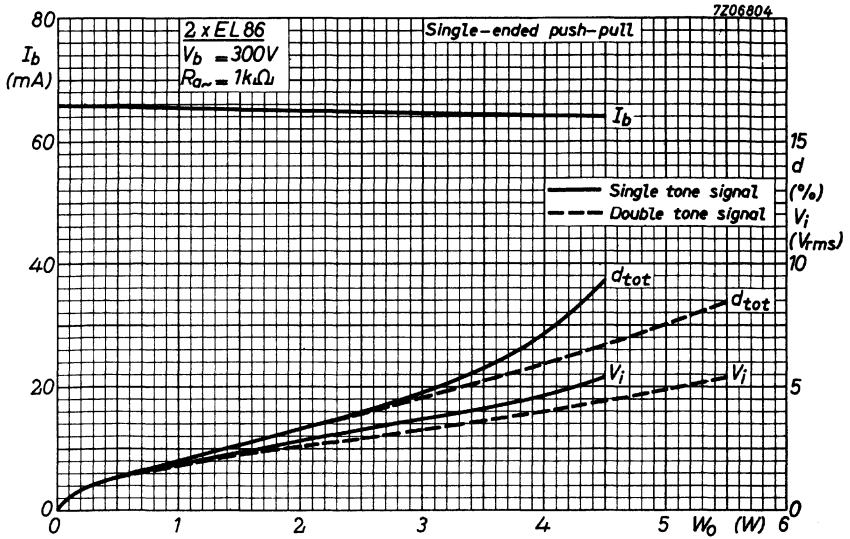

**A.F. OUTPUT PENTODE**

Pentode intended for use as A. F. power amplifier:

**HEATING** : Indirect by A. C. or D. C. ; parallel supply

|                |       |        |
|----------------|-------|--------|
| Heater voltage | $V_f$ | 6.3 V  |
| Heater current | $I_f$ | 200 mA |

**LIMITING VALUES** (Design centre rating system)

|                           |          |      |       |
|---------------------------|----------|------|-------|
| Cathode to heater voltage | $V_{kf}$ | max. | 100 V |
|---------------------------|----------|------|-------|

-----  
For further data and curves of this type  
please refer to type PL95  
-----



## LINE OUTPUT PENTODE

Beam pentode intended for use as line output tube in television receivers.

**HEATING:** Indirect by A.C. or D.C.; parallel supply

|                |       |        |
|----------------|-------|--------|
| Heater voltage | $V_f$ | 6.3 V  |
| Heater current | $I_f$ | 1.38 A |

**LIMITING VALUES** (Design centre rating system)

Cathode to heater voltage

|                       |           |                          |
|-----------------------|-----------|--------------------------|
| DC + peak, k positive | $V_{kf}$  | max. 200 V               |
| k negative            | $-V_{kf}$ | max. 200 V <sup>3)</sup> |

Anode dissipation

See graph below

Grid No. 2 dissipation

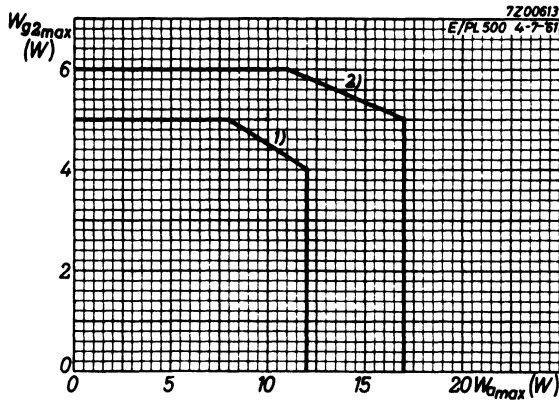

- 1) Design centre limits for  $W_a$  and  $W_{g_2}$ .
- 2) These limits for  $W_a$  and  $W_{g_2}$  should not be exceeded with a nominal tube operating in a normal line deflection circuit under the worst probable conditions.
- 3) D.C. component max. 100 V.

-----  
 For further data and curves of this type  
 please refer to type PL 504  
 -----



## A.F. OUTPUT PENTODE

Beam pentode intended for use as A.F. power amplifier.

| QUICK REFERENCE DATA    |                |         |
|-------------------------|----------------|---------|
| Anode current           | $I_a$          | 110 mA  |
| Transconductance        | $S$            | 23 mA/V |
| Amplification factor    | $\mu_{g_2g_1}$ | 13      |
| Output power (class AB) | $W_o$          | 40 W    |

**HEATING:** Indirect by A.C. or D.C.; parallel supply

Heater voltage

$V_f$  6.3 V

Heater current

$I_f$  1.05 A

### DIMENSIONS AND CONNECTIONS

Base: Magnoval

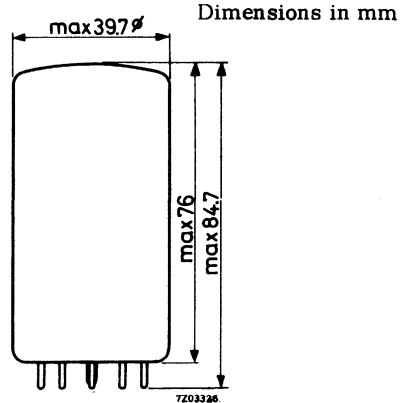
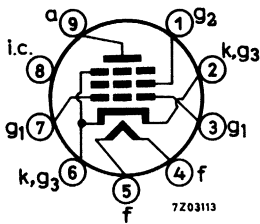

### CAPACITANCES

Anode to all except grid No. 1

$C_a(g_1)$  13.5 pF

Grid No. 1 to all except anode

$C_{g_1(a)}$  22.5 pF

Anode to grid No. 1

$C_{ag_1}$  1.7 pF

Grid No. 1 to heater

$C_{g_1f}$  0.325 pF

**TYPICAL CHARACTERISTICS**

|                      |              |      |            |
|----------------------|--------------|------|------------|
| Anode voltage        | $V_a$        | 250  | V          |
| Grid No.2 voltage    | $V_{g2}$     | 250  | V          |
| Grid No.1 voltage    | $V_{g1}$     | 14.0 | V          |
| Anode current        | $I_a$        | 110  | mA         |
| Grid No.2 current    | $I_{g2}$     | 7.0  | mA         |
| Transconductance     | $S$          | 23   | mA/V       |
| Amplification factor | $\mu_{g2g1}$ | 13   |            |
| Internal resistance  | $R_i$        | 5.4  | k $\Omega$ |

**OPERATING CHARACTERISTICS**

Class AB, two tubes in push-pull

|                           |              |       |                       |
|---------------------------|--------------|-------|-----------------------|
| Anode supply voltage      | $V_{ba}$     | 265   | V                     |
| Grid No.2 supply voltage  | $V_{bg2}$    | 265   | V                     |
| Common cathode resistor   | $R_k$        | 56    | $\Omega$              |
| Load resistance           | $R_{aa\sim}$ | 2.4   | k $\Omega$            |
| Grid No.1 driving voltage | $V_i$        | 0     | 12.2 V <sub>RMS</sub> |
| Anode current             | $I_a$        | 2x115 | 2x125 mA              |
| Grid No.2 current         | $I_{g2}$     | 2x7.5 | 2x35.0 mA             |
| Output power              | $W_o$        | 0     | 40 W                  |
| Distortion                | $d_{tot}$    | -     | 5 %                   |



**LIMITING VALUES** (Design centre rating system)

|                                    |           |             |
|------------------------------------|-----------|-------------|
| Anode voltage                      | $V_{a0}$  | max. 550 V  |
|                                    | $V_a$     | max. 300 V  |
| Grid No.2 voltage                  | $V_{g20}$ | max. 550 V  |
|                                    | $V_{g2}$  | max. 300 V  |
| Anode dissipation                  | $W_a$     | see below   |
| Grid No.2 dissipation              |           |             |
| average                            | $W_{g2}$  | see below   |
| peak                               | $W_{g2p}$ | see below   |
| Cathode current                    | $I_k$     | max. 200 mA |
| Grid No.1 resistor, automatic bias | $R_{g1}$  | max. 0.5 MΩ |
| Cathode to heater voltage          | $V_{kf}$  | max. 100 V  |

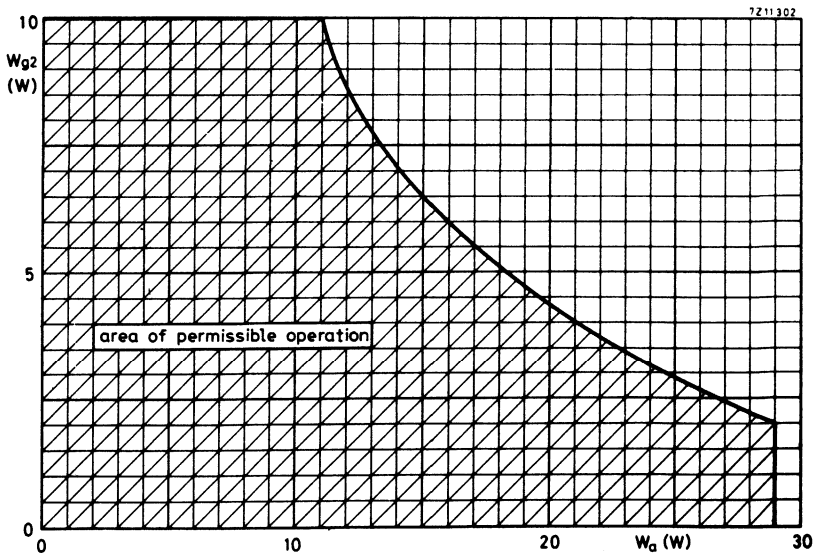

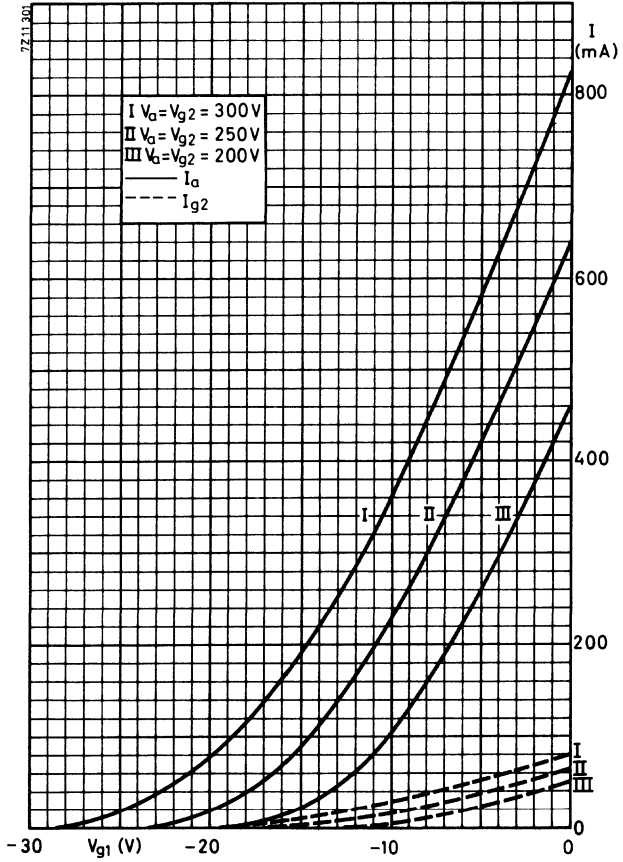

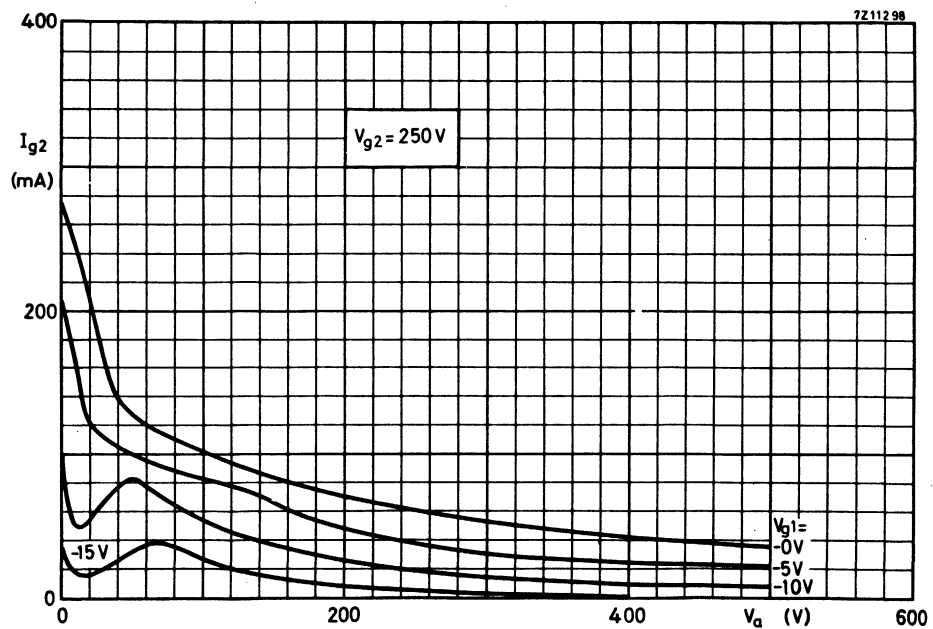
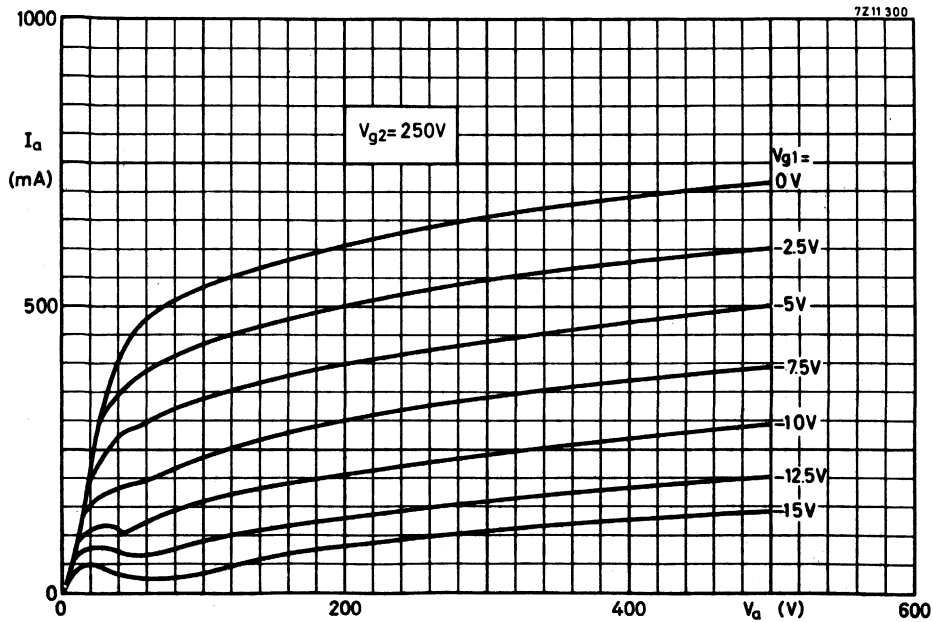

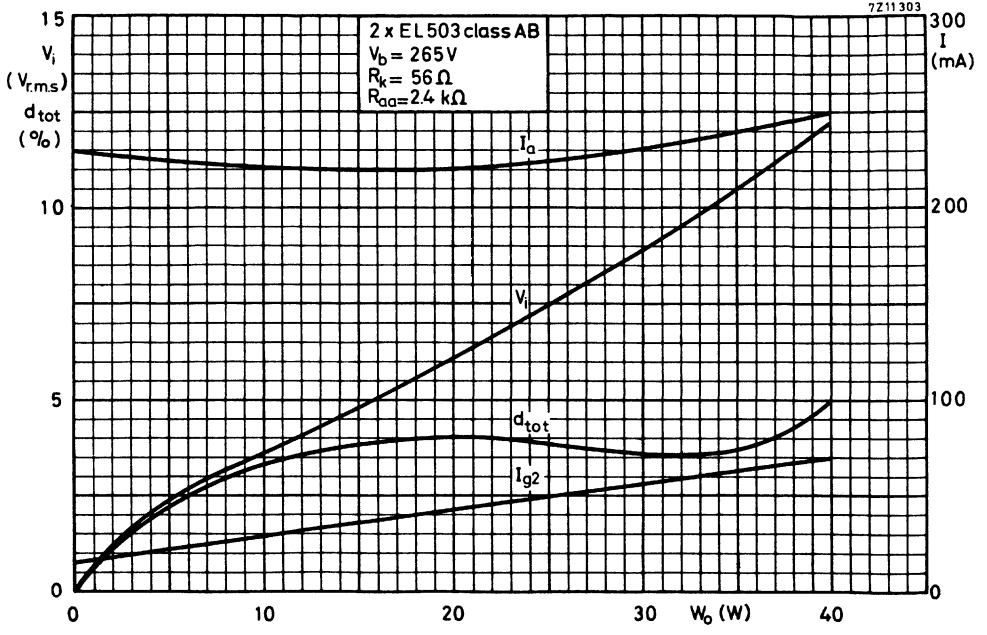

## LINE OUTPUT PENTODE

Beam pentode intended for use as line output tube in television receivers.

**HEATING:** Indirect by A. C. or D. C. ; parallel supply

|                |       |        |
|----------------|-------|--------|
| Heater voltage | $V_f$ | 6.3 V  |
| Heater current | $I_f$ | 1.38 A |

**LIMITING VALUES** (Design centre rating system)

Cathode to heater voltage,

|                       |           |                     |
|-----------------------|-----------|---------------------|
| DC + peak, k positive | $V_{kf}$  | max. 200 V          |
| k negative            | $-V_{kf}$ | 200 V <sup>1)</sup> |

-----  
 For further data and curves of this type  
 please refer to type PL 504  
 -----

<sup>1)</sup> DC component max. 100 V.



**FRAME OUTPUT PENTODE**

Pentode intended for use as frame output amplifier in colour television receivers.

**HEATING:** Indirect by A.C. or D.C.; parallel supply

|                |       |        |
|----------------|-------|--------|
| Heater voltage | $V_f$ | 6.3 V  |
| Heater current | $I_f$ | 825 mA |

**LIMITING VALUES** (Design centre rating system)

Cathode to heater voltage  $V_{kf}$  max. 100 V

-----  
For further data of this type please  
refer to type PL508  
-----





**LINE OUTPUT PENTODE**

Output pentode intended for colour TV line deflection circuits.

**HEATING:** Indirect by A.C. or D.C. ; parallel supply

|                |       |     |   |
|----------------|-------|-----|---|
| Heater voltage | $V_f$ | 6.3 | V |
| Heater voltage | $I_f$ | 2   | A |

**LIMITING VALUES** (Design centre rating system)

Cathode to heater voltage,

|                       |           |          |                 |
|-----------------------|-----------|----------|-----------------|
| DC + peak, k positive | $V_{kf}$  | max. 200 | V               |
| k negative            | $-V_{kf}$ | max. 200 | V <sup>1)</sup> |

-----  
 For further data and curves of this type  
 please refer to type PL 509  
 -----

<sup>1)</sup> DC component max. 100 V.



## LINE OUTPUT PENTODE

Output pentode intended for colour TV line deflection circuits.

HEATING: Indirect by A.C. or D.C. ; parallel supply

|                |       |     |   |
|----------------|-------|-----|---|
| Heater voltage | $V_f$ | 6.3 | V |
| Heater voltage | $I_f$ | 2   | A |

LIMITING VALUES (Design centre rating system)

Cathode to heater voltage,

|                       |           |      |     |      |
|-----------------------|-----------|------|-----|------|
| DC + peak, k positive | $V_{kf}$  | max. | 200 | V    |
| k negative            | $-V_{kf}$ | max. | 200 | V 1) |

-----  
 For further data and curves of this type  
 please refer to type PL519  
 -----

1) DC component max. 100 V.



**VIDEO OUTPUT PENTODE**

Luminance output tube in colour TV receivers

HEATING: Indirect by A.C. or D.C.; parallel supply

Heater voltage

$V_f$  6.3 V

Heater current

$I_f$  800 mA

LIMITING VALUES (Design centre rating system)

Cathode to heater voltage

$V_{kf}$  max. 100 V

-----  
For further data of this type please refer  
to type PL802  
-----



## TUNING INDICATOR

Indicator tube with triode amplifier intended for use as tuning indicator or for modulation control.

**HEATING:** Indirect by A.C. or D.C.; parallel supply

|                |       |        |
|----------------|-------|--------|
| Heater voltage | $V_f$ | 6.3 V  |
| Heater current | $I_f$ | 210 mA |

### DIMENSIONS AND CONNECTIONS

Dimensions in mm

Base: Noval

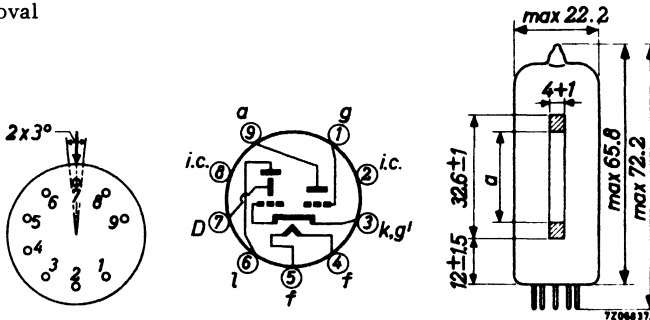

The arrow near pin 7 indicates the viewing direction.

### OPERATING CHARACTERISTICS (D connected to a)

|   |            |            |           |
|---|------------|------------|-----------|
| Supply voltage                          | $V_b$      | 250        | V         |
| Luminescent screen voltage              | $V_l$      | 250        | V         |
| Anode and deflection electrode resistor | $R_{a, D}$ | 470        | $k\Omega$ |
| Grid resistor                           | $R_g$      | 3          | $M\Omega$ |
| Grid supply voltage                     | $V_{bg}$   | 0          | -22 V     |
| Anode and deflection electrode current  | $I_{a+D}$  | 0.45       | 0.06 mA   |
| Luminescent screen current              | $I_l$      | 1.0        | 1.8 mA    |
| Shadow length                           | a          | $21 \pm 5$ | 0 mm      |

## LIMITING VALUES (Design centre rating system)

|                              |              |                   |
|------------------------------|--------------|-------------------|
| Anode voltage                | $V_{a_0}$    | max. 550 V        |
|                              | $V_a$        | max. 300 V        |
| Anode dissipation            | $W_a$        | max. 0.5 W        |
| Deflection electrode voltage | $V_{D_0}$    | max. 550 V        |
|                              | $V_D$        | max. 300 V        |
| Luminescent screen voltage   | $V_{\ell_0}$ | max. 550 V        |
|                              | $V_{\ell}$   | max. 300 V        |
|                              | $V_{\ell}$   | min. 170 V        |
| Cathode current              | $I_k$        | max. 3 mA         |
| Grid resistor                | $R_g$        | max. 3 M $\Omega$ |
| Cathode to heater voltage    | $V_{kf}$     | max. 100 V        |
| Bulb temperature             | $t_{bulb}$   | max. 120 °C       |

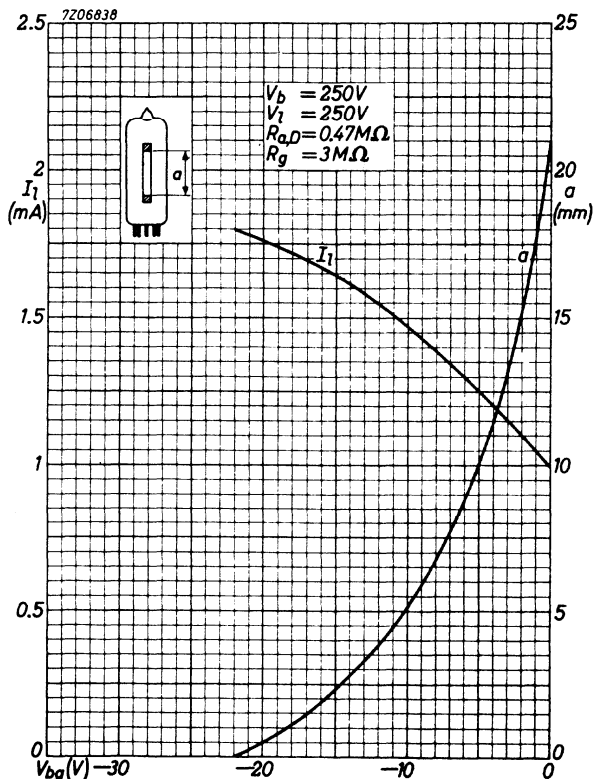



## TUNING INDICATOR

Tuning indicator tube.

**HEATING:** Indirect by A.C. or D.C.; series or parallel supply

|                |       |        |
|----------------|-------|--------|
| Heater voltage | $V_f$ | 6.3 V  |
| Heater current | $I_f$ | 300 mA |

### DIMENSIONS AND CONNECTIONS

Dimensions in mm

Base: Noval

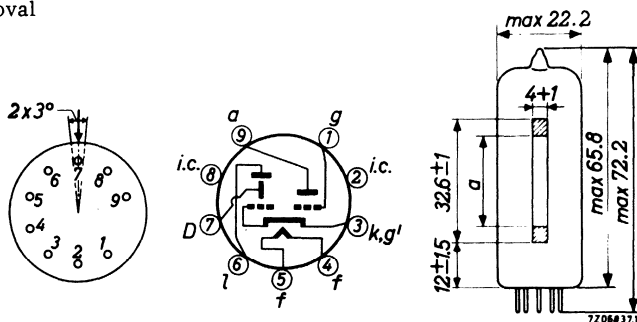

The arrow near pin 7 indicates the viewing direction.

### OPERATING CHARACTERISTICS (D connected to a)

|   |           |                 |                  |
|---|-----------|-----------------|------------------|
| Supply voltage                          | $V_b$     | 250             | V                |
| Luminescent screen voltage              | $V_l$     | 250             | V                |
| Anode and deflection electrode resistor | $R_{a,D}$ | 100             | $k\Omega$        |
| Grid resistor                           | $R_g$     | 3               | $M\Omega$        |
| Grid supply voltage                     | $V_{bg}$  | 0   -10   -15   | V                |
| Anode and deflection electrode current  | $I_{a+D}$ | 2.0   0.5   0.2 | mA               |
| Luminescent screen current              | $I_l$     | 1.0   1.8   2.0 | mA               |
| Shadow length                           | $a$       | 21   0   -1.5   | mm <sup>1)</sup> |

<sup>1)</sup> A negative value of "a" means overlapping:

The grid bias for  $a = 0$  is reduced by decreasing  $V_l$ .

The measure of overlapping at  $V_g = -15$  V will then increase (see page 4).

**LIMITING VALUES** (Design centre rating system)

|                              |               |                      |
|------------------------------|---------------|----------------------|
| Anode voltage                | $V_{a_0}$     | max. 550 V           |
|                              | $V_a$         | max. 300 V           |
| Anode dissipation            | $W_a$         | max. 0.6 W           |
| Deflection electrode voltage | $V_{D_0}$     | max. 550 V           |
|                              | $V_D$         | max. 300 V           |
| Luminescent screen voltage   | $V_{l_0}$     | max. 550 V           |
|                              | $V_l$         | max. 300 V           |
|                              | $V_{\bar{l}}$ | min. 170 V           |
| Grid resistor                | $R_g$         | max. 3 $M\Omega$     |
| Cathode current              | $I_k$         | max. 5 mA            |
| Cathode to heater voltage    | $V_{kf}$      | max. 250 V           |
| Bulb temperature             | $t_{bulb}$    | max. 120 $^{\circ}C$ |

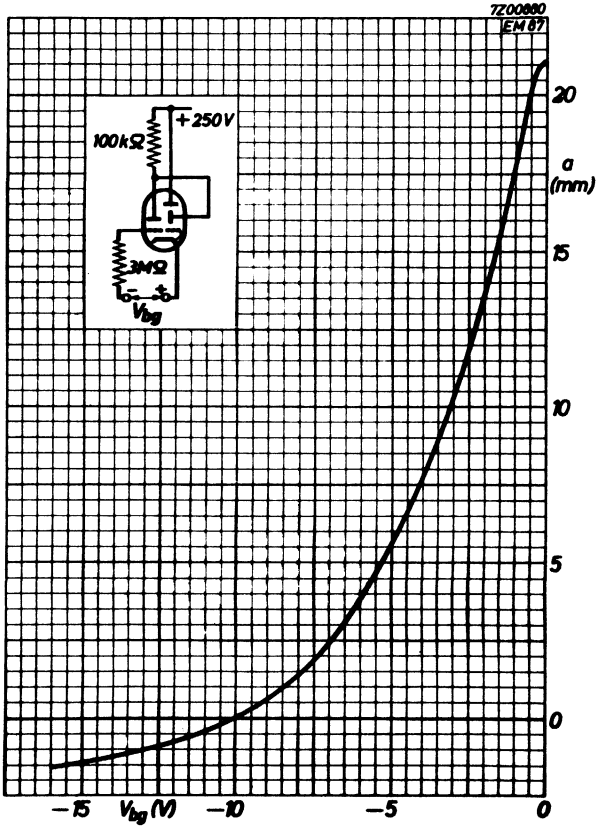

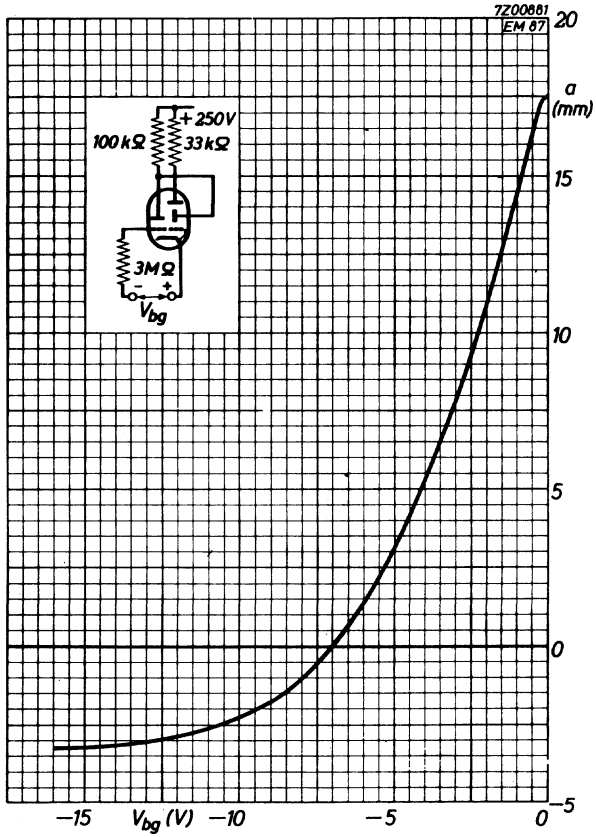

**BOOSTER DIODE**

Booster diode intended for use in line time-base circuits of television receivers.

**HEATING:** Indirect by A. C. or D. C.; parallel supply

Heater current

$V_f$  6.3 V

Heater voltage

$I_f$  810 mA

-----  
For further data and curves  
please refer to type PY81  
-----



**BOOSTER DIODE**

Booster diode intended for use in line time base circuits of television receivers.

**HEATING:** Indirect by A.C. or D.C.; parallel supply

Heater voltage

$V_f$  6.3 V

Heater current

$I_f$  1.55 A

-----  
For further data and curves of this type  
please refer to type PY88  
-----





**BOOSTER DIODE**

Booster diode intended for use in time base circuits of colour television receivers.

**HEATING:** Indirect by A.C. or D.C.; parallel supply

Heater voltage

$\frac{V_f}{\quad} = 6.3 \text{ V}$

Heater current

$I_f = 2.1 \text{ A}$

-----  
For further data and curves of this type  
please refer to type PY500  
-----



**BOOSTER DIODE**

Booster diode intended for use in time base circuits of colour television receivers.

**HEATING:** Indirect by A.C. or D.C.; parallel supply

Heater voltage

$V_f$  6.3 V

Heater current

$I_f$  2.1 A

-----  
For further data and curves of this type  
please refer to type PY500A  
-----



## DOUBLE ANODE RECTIFYING TUBE

Double anode high vacuum rectifying tube

| <b>QUICK REFERENCE DATA</b> |          |       |           |
|-----------------------------|----------|-------|-----------|
| Transformer voltage         | $V_{tr}$ | 2x350 | $V_{RMS}$ |
| D.C. current                | $I_o$    | 90    | mA        |

**HEATING:** Indirect by A.C.; parallel supply

|                |       |     |    |
|----------------|-------|-----|----|
| Heater voltage | $V_f$ | 6.3 | V  |
| Heater current | $I_f$ | 600 | mA |

### DIMENSIONS AND CONNECTIONS

Dimensions in mm

Base: Noval

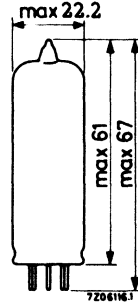
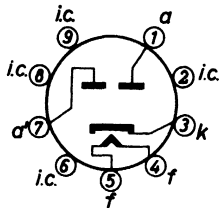

### OPERATING CHARACTERISTICS as two-phase half-wave rectifier

|                                     |            |       |       |       |       |           |
|-------------------------------------|------------|-------|-------|-------|-------|-----------|
| Transformer voltage                 | $V_{tr}$   | 2x250 | 2x275 | 2x300 | 2x350 | $V_{RMS}$ |
| D.C. output voltage                 | $V_o$      | 260   | 285   | 310   | 360   | V         |
| D.C. current                        | $I_o$      | 90    | 90    | 90    | 90    | mA        |
| Protecting resistance               | $R_t$      | 2x125 | 2x175 | 2x215 | 2x300 | $\Omega$  |
| Input capacitor of smoothing filter | $C_{filt}$ | 50    | 50    | 50    | 50    | $\mu F$   |

**LIMITING VALUES** (Design centre rating system)

|   |            |       |       |           |       |           |
|---|------------|-------|-------|-----------|-------|-----------|
| Transformer voltage                             | $V_{tr}$   | max.  | 2x350 | $V_{RMS}$ |       |           |
| D.C. current                                    | $I_o$      | max.  | 90    | mA        |       |           |
| Cathode to heater voltage,<br>peak, k pos       | $V_{kf_p}$ | max.  | 500   | V         |       |           |
| Input capacitor of<br>smoothing filter          | $C_{filt}$ | max.  | 50    | $\mu F$   |       |           |
| Protecting resistance<br>at transformer voltage | $R_t$ min. | 2x125 | 2x175 | 2x215     | 2x300 | $\Omega$  |
|   | $V_{tr}$   | 2x250 | 2x275 | 2x300     | 2x350 | $V_{RMS}$ |

## DOUBLE ANODE RECTIFYING TUBE

Double anode high vacuum rectifying tube.

| QUICK REFERENCE DATA |          |                 |
|----------------------|----------|-----------------|
| Transformer voltage  | $V_{tr}$ | 2x450 $V_{RMS}$ |
| D.C. current         | $I_o$    | 100 mA          |

**HEATING:** Indirect by A.C.; parallel supply

Heater voltage

$V_f$  6.3 V

Heater current

$I_f$  1 A

### DIMENSIONS AND CONNECTIONS

Dimensions in mm

Base: Noval

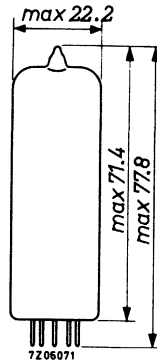
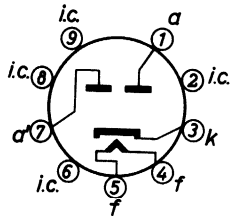





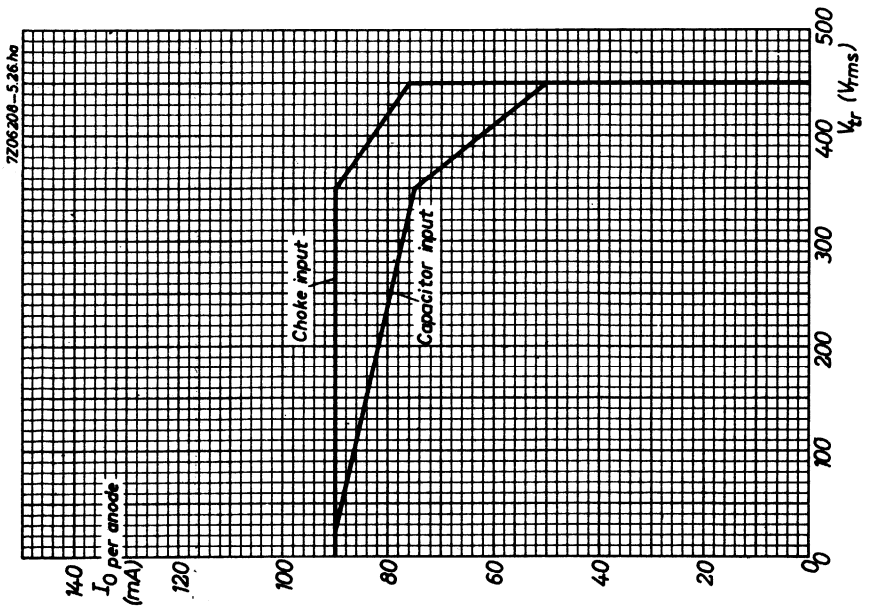
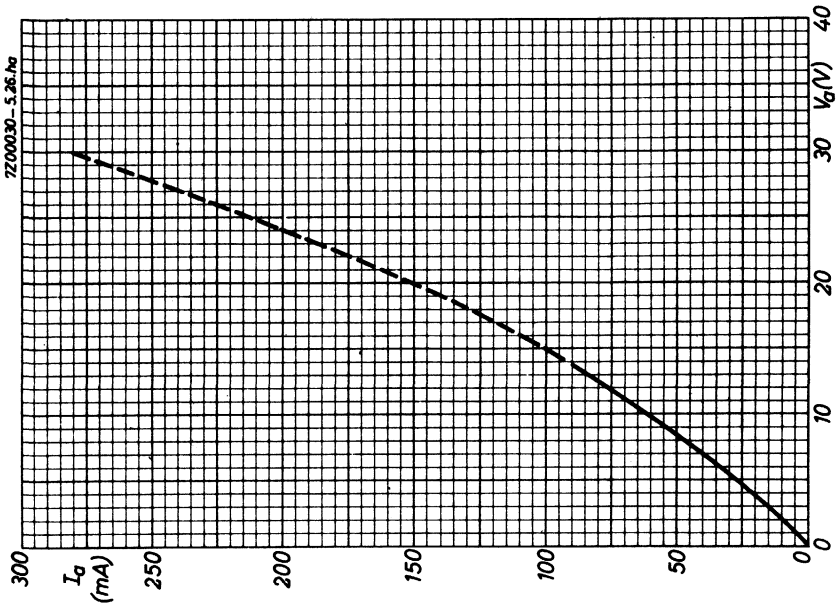

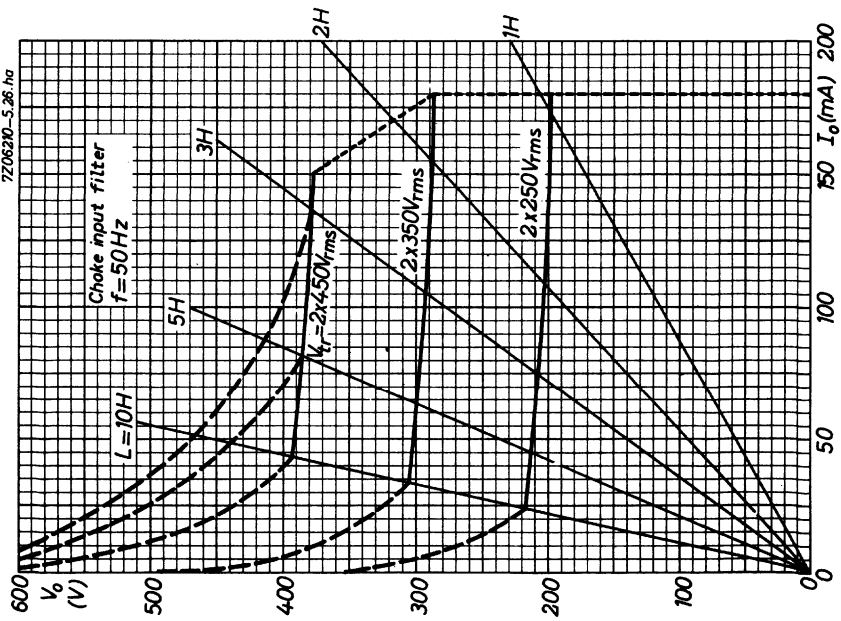
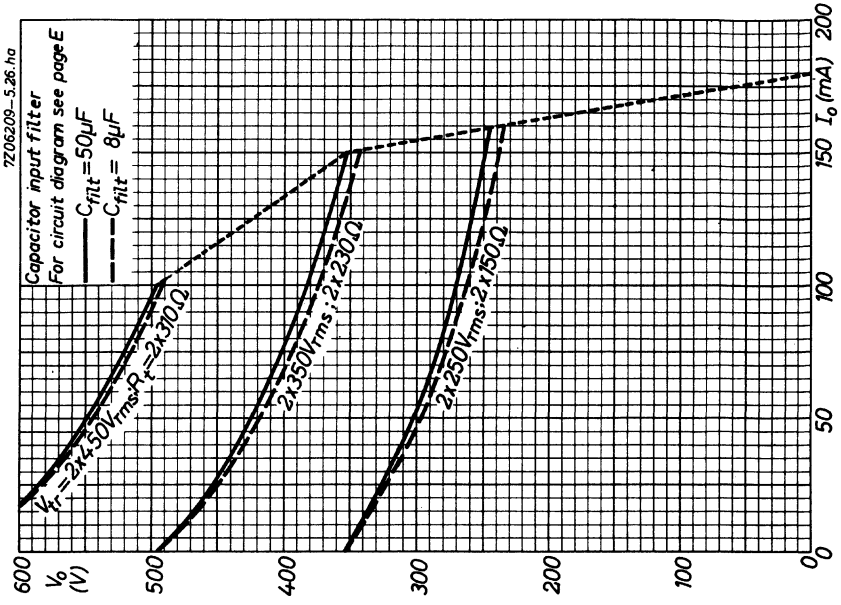

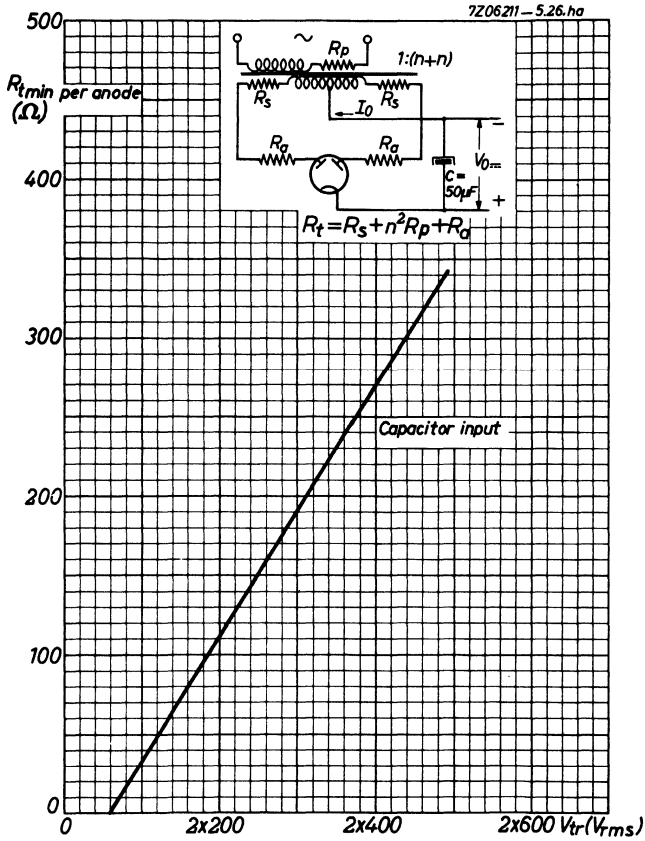



## SINGLE ANODE E.H.T. RECTIFYING TUBE

Single anode E.H.T. rectifying tube intended for use in colour television receivers.

The GY501 has a chemically treated envelope to avoid flash-over under conditions of high humidity and low atmospheric pressure (45 cm Hg).

| QUICK REFERENCE DATA |       |        |
|----------------------|-------|--------|
| D.C. output voltage  | $V_o$ | 25 kV  |
| Anode current        | $I_a$ | 1.5 mA |

**HEATING:** Indirect by A.C. or D.C.; parallel supply

|                |       |                    |
|----------------|-------|--------------------|
| Heater voltage | $V_f$ | $3.15 \text{ V}^1$ |
| Heater current | $I_f$ | 400 mA             |

### DIMENSIONS AND CONNECTIONS

Base: Magnoval

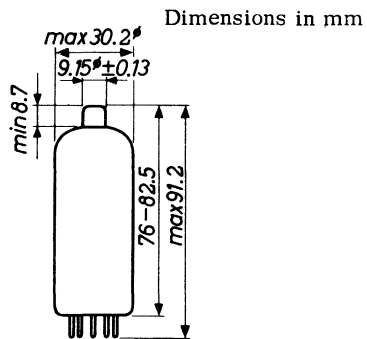
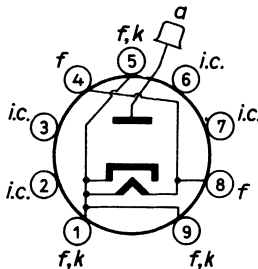

Pins 1, 5 and 9 may be used to connect an anti-corona ring.

Circuit elements having the same potential as the heater (e.g. a series resistor) may be connected to pins 3 and 7. These pins must never be earthed.

**Precaution:** X-ray shielding may be required to give protection against excessive radiation.

<sup>1</sup>) Under nominal operating conditions and with the longterm average value of  $I_a$  to be expected in practice,  $V_{fRMS}$  should be 3.15 V.

The heater voltage deviation resulting from spread or variation of operating conditions should be limited to the values indicated by the diagram in fig. A.

## CAPACITANCES

|                  |          |        |
|------------------|----------|--------|
| Anode to cathode | $C_{ak}$ | 1.2 pF |
|------------------|----------|--------|

## OPERATING CHARACTERISTICS

|                |       |        |
|----------------|-------|--------|
| Output voltage | $V_o$ | 25 kV  |
| Anode current  | $I_a$ | 1.5 mA |

## LIMITING VALUES (Design centre rating system)

|                                      |              |      |                      |
|--------------------------------------|--------------|------|----------------------|
| Peak inverse voltage (absolute max.) | $V_{ainv_p}$ | max. | 35 kV <sup>1)</sup>  |
| Output voltage (absolute max.)       | $V_o$        | max. | 27.5 kV              |
| Output current, average              | $I_o$        | max. | 1.7 mA               |
| peak                                 | $I_{op}$     | max. | 100 mA <sup>2)</sup> |

<sup>1)</sup> The negative peak due to ringing in the line output transformer should be taken into account.

Max. pulse duration 22% of a cycle and 18  $\mu$ s.

<sup>2)</sup> Design max. rating system

Max. pulse duration 10% of a line scanning cycle with a max. of 10  $\mu$ s.

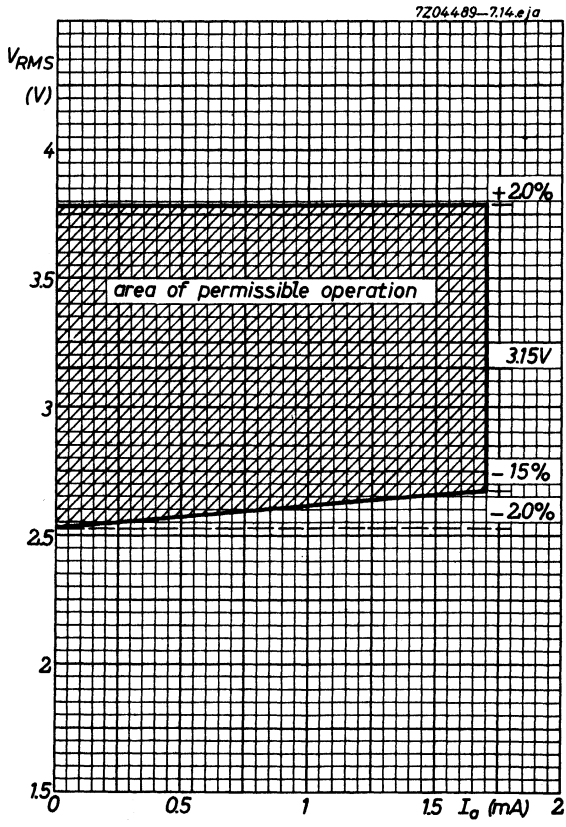

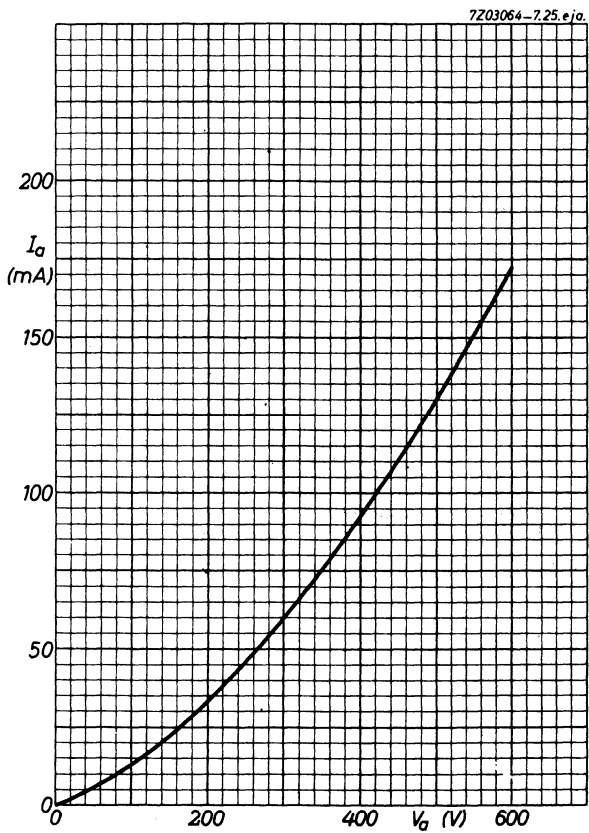



## DOUBLE ANODE RECTIFYING TUBE

Double anode high vacuum rectifying tube.

| QUICK REFERENCE DATA |          |       |           |
|----------------------|----------|-------|-----------|
| Transformer voltage  | $V_{tr}$ | 2x450 | $V_{RMS}$ |
| D.C. current         | $I_o$    | 250   | mA        |

**HEATING:** Indirect by A.C.; parallel supply

Heater voltage

$V_f$  5 V

Heater current

$I_f$  1.9 A

### DIMENSIONS AND CONNECTIONS

Dimensions in mm

Base: Octal

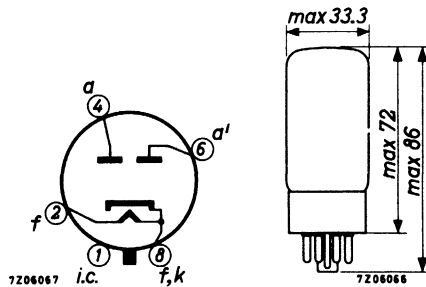

**OPERATING CHARACTERISTICS**

As two-phase half-wave rectifier with capacitor input

|                                     |            |       |       |       |           |
|-------------------------------------|------------|-------|-------|-------|-----------|
| Transformer voltage                 | $V_{tr}$   | 2x300 | 2x350 | 2x400 | $V_{RMS}$ |
| D.C. output voltage                 | $V_o$      | 330   | 380   | 430   | V         |
| D.C. current                        | $I_o$      | 250   | 250   | 250   | mA        |
| Protecting resistance               | $R_t$      | 2x75  | 2x100 | 2x125 | $\Omega$  |
| Input capacitor of smoothing filter | $C_{filt}$ | 60    | 60    | 60    | $\mu F$   |
| Transformer voltage                 | $V_{tr}$   | 2x450 | 2x500 | 2x550 | $V_{RMS}$ |
| D.C. output voltage                 | $V_o$      | 480   | 560   | 640   | V         |
| D.C. current                        | $I_o$      | 250   | 200   | 160   | mA        |
| Protecting resistance               | $R_t$      | 2x150 | 2x175 | 2x200 | $\Omega$  |
| Input capacitor of smoothing filter | $C_{filt}$ | 60    | 60    | 60    | $\mu F$   |

As two-phase half-wave rectifier with choke input

|                     |          |       |       |       |           |
|---------------------|----------|-------|-------|-------|-----------|
| Transformer voltage | $V_{tr}$ | 2x300 | 2x350 | 2x400 | $V_{RMS}$ |
| D.C. output voltage | $V_o$    | 250   | 290   | 330   | V         |
| D.C. current        | $I_o$    | 250   | 250   | 250   | mA        |
| Protecting resistor | $R_t$    | 0     | 0     | 0     | $\Omega$  |
| Choke               | L        | 10    | 10    | 10    | H         |
| Transformer voltage | $V_{tr}$ | 2x450 | 2x500 | 2x550 | $V_{RMS}$ |
| D.C. output voltage | $V_o$    | 375   | 420   | 465   | V         |
| D.C. current        | $I_o$    | 250   | 250   | 225   | mA        |
| Protecting resistor | $R_t$    | 0     | 0     | 0     | $\Omega$  |
| Choke               | L        | 10    | 10    | 10    | H         |

**LIMITING VALUES** (Design centre rating system)

See also page 4

Capacitor input

|  |                     |   |
|--|---------------------|---|
| Anode voltage,<br>peak inverse                     | $V_{a\text{ invp}}$ | max. 1500 V                                   |
| D.C. current                                       | $I_o$               | max. See page 4                               |
| Anode peak current                                 | $I_{ap}$            | max. 750 mA                                   |
| Input capacitor of<br>smoothing filter             | $C_{\text{filt}}$   | max. 60 $\mu\text{F}$                         |
| Protecting resistance<br>at transformer<br>voltage | $R_{t\text{ min.}}$ | 2x50 2x75 2x100 2x125 2x150 2x175 $\Omega$    |
|  | $V_{tr}$            | 2x300 2x350 2x400 2x450 2x500 2x550 $V_{RMS}$ |

Choke input

|                                |                     |                 |
|--------------------------------|---------------------|-----------------|
| Anode voltage,<br>peak inverse | $V_{a\text{ invp}}$ | max. 1500 V     |
| D.C. current                   | $I_o$               | max. See page 4 |
| Anode peak current             | $I_{ap}$            | max. 750 mA     |

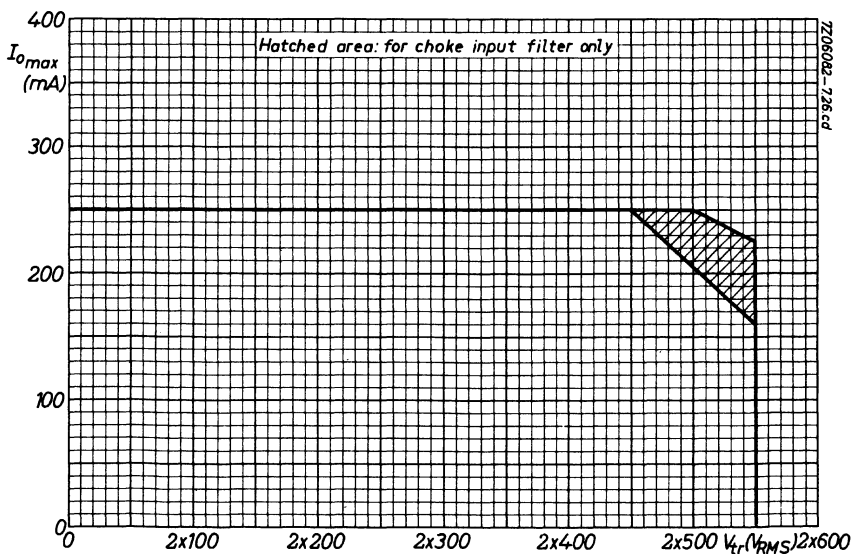
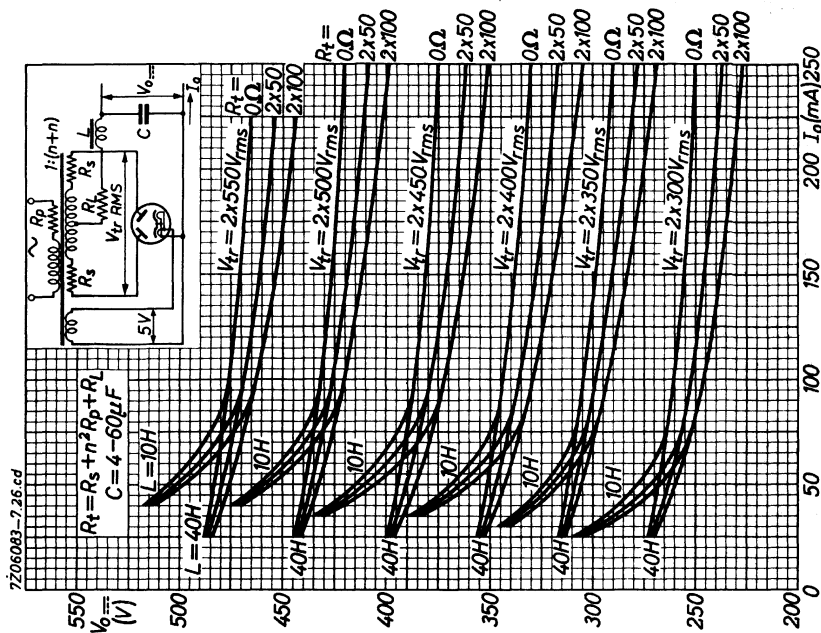

**TRIPLE DIODE-TRIODE**

Triple diode-triode, intended for video and FM and AM audio signal detection and A.F. signal amplification.

**HEATING:** Indirect by A.C. or D.C.; series supply

|                |       |            |    |
|----------------|-------|------------|----|
| Heater current | $I_f$ | <u>300</u> | mA |
| Heater voltage | $V_f$ | 9.5        | V  |

-----  
For further data and curves  
please refer to UABC80  
-----



## U.H.F. TRIODE

Triode intended for use as grounded grid U.H.F. amplifier, oscillator or mixer for bands IV and V.

| QUICK REFERENCE DATA |       |    |      |
|----------------------|-------|----|------|
| Anode current        | $I_a$ | 12 | mA   |
| Transconductance     | $S$   | 14 | mA/V |
| Amplification factor | $\mu$ | 68 | -    |

**HEATING:** Indirect by A.C. or D.C.; series supply

Heater current  $I_f$  300 mA

Heater voltage  $V_f$  3.8 V

### DIMENSIONS AND CONNECTIONS

Dimensions in mm

Base: Noval

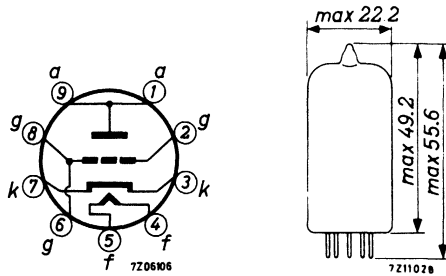

**OPERATING CHARACTERISTICS**As grounded grid amplifier

|                  |       |              |
|------------------|-------|--------------|
| Anode voltage    | $V_a$ | 175 V        |
| Cathode resistor | $R_k$ | 125 $\Omega$ |
| Anode current    | $I_a$ | 12 mA        |
| Transconductance | $S$   | 14 mA/V      |

As self-oscillating mixer

|                |          |               |
|----------------|----------|---------------|
| Supply voltage | $V_{ba}$ | 220 V         |
| Anode resistor | $R_a$    | 5.6 $k\Omega$ |
| Grid resistor  | $R_g$    | 47 $k\Omega$  |
| Anode current  | $I_a$    | 12 mA         |
| Grid current   | $I_g$    | 50 $\mu A$    |

**LIMITING VALUES** (Design centre rating system)

|                           |                  |                          |
|---------------------------|------------------|--------------------------|
| Anode voltage             | $V_{a0}$         | max. 550 V               |
|                           | $V_a$            | max. 220 V               |
| Anode dissipation         | $W_a$            | max. 2.2 W               |
| Cathode current           | $I_k$            | max. 20 mA               |
| Grid voltage              | $-V_g$           | max. 50 V                |
| Grid resistor             | $R_g$            | max. 1 $M\Omega$         |
| Cathode to heater voltage | $V_{kf(k\ pos)}$ | max. 100 V <sup>1)</sup> |

<sup>1)</sup> A.C. component max. 50  $V_{RMS}$ .



**CAPACITANCES**Without external shield

|                           |            |         |
|---------------------------|------------|---------|
| Anode to grid             | $C_{ag}$   | 2.2 pF  |
| Anode to cathode          | $C_{ak}$   | 0.24 pF |
| Grid to cathode           | $C_{gk}$   | 3.5 pF  |
| Grid to heater            | $C_{gf}$   | 0.27 pF |
| Cathode to grid + heater  | $C_{k/gf}$ | 6.3 pF  |
| Grid to cathode + heater  | $C_{g/kf}$ | 3.8 pF  |
| Anode to cathode + heater | $C_{a/kf}$ | 0.35 pF |
| Anode to grid + heater    | $C_{a/gf}$ | 2.3 pF  |

With external shield

|                                   |             |        |
|-----------------------------------|-------------|--------|
| Anode to grid + screen            | $C_{a/gs}$  | 3.3 pF |
| Cathode + heater to grid + screen | $C_{kf/gs}$ | 4.1 pF |
| Anode to cathode + heater         | $C_{a/kf}$  | 0.3 pF |

**TYPICAL CHARACTERISTICS**

|                             |              |                    |
|-----------------------------|--------------|--------------------|
| Anode voltage               | $V_a$        | 175 V              |
| Grid voltage                | $V_g$        | -1.5 V             |
| Anode current               | $I_a$        | 12 mA              |
| Transconductance            | $S$          | 14 mA/V            |
| Amplification factor        | $\mu$        | 68 -               |
| Equivalent noise resistance | $R_{eq}$     | 230 $\Omega$       |
| Increase $C_g$              | $\Delta C_g$ | 2 pF <sup>1)</sup> |

<sup>1)</sup> Difference between  $C_g$  of cold and hot tube.

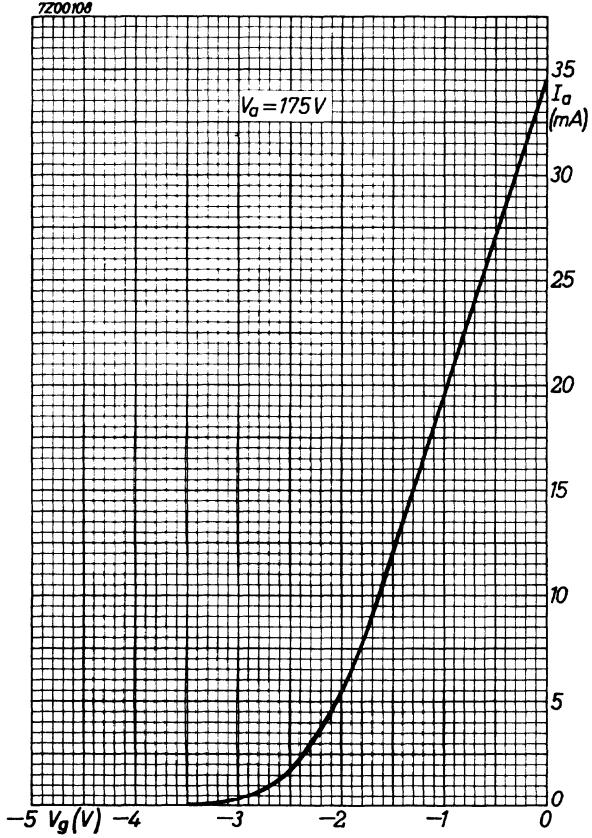

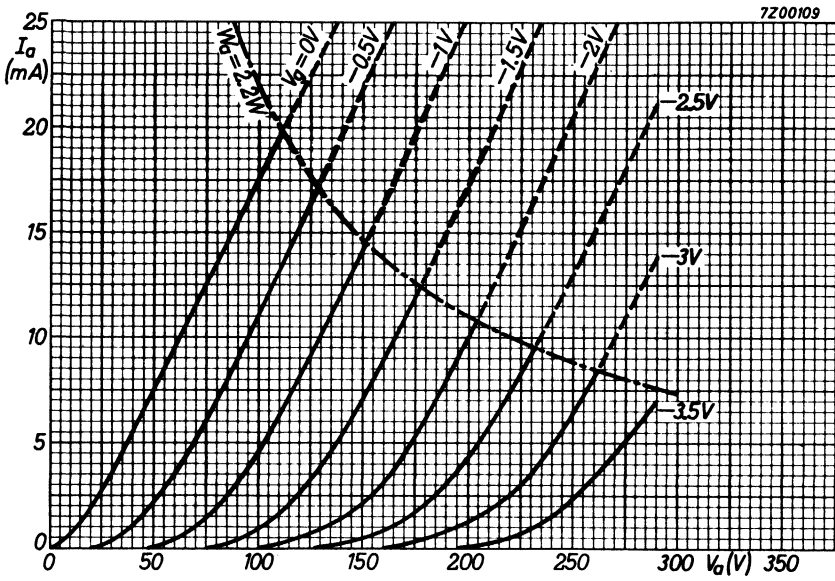

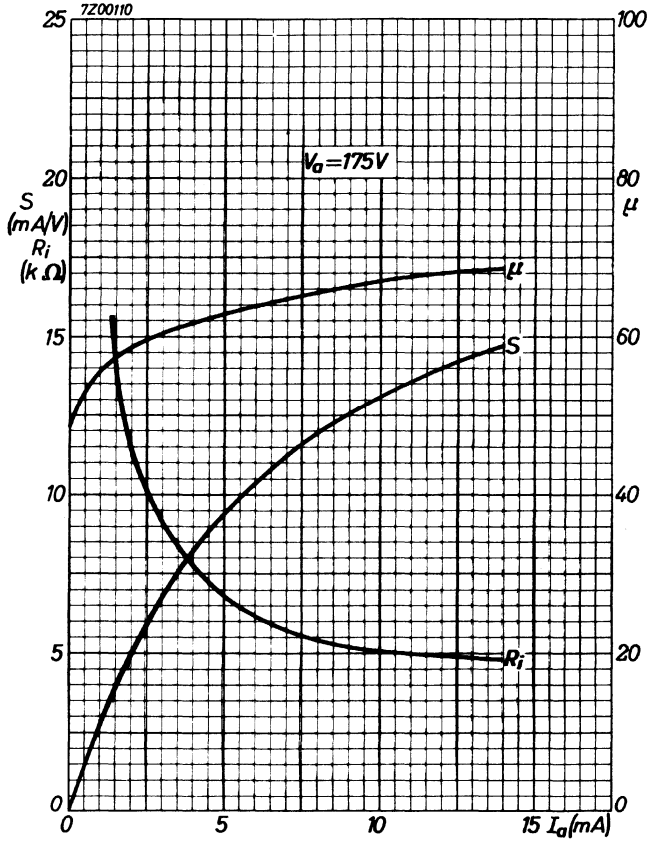

## U.H.F. TRIODE

Triode intended for use as grounded grid U.H.F. amplifier for bands IV and V.

| QUICK REFERENCE DATA |       |           |
|----------------------|-------|-----------|
| Anode current        | $I_a$ | 12.5 mA   |
| Transconductance     | $S$   | 13.5 mA/V |
| Amplification factor | $\mu$ | 65        |

**HEATING:** Indirect by A.C. or D.C.; series supply

|                |       |        |
|----------------|-------|--------|
| Heater current | $I_f$ | 300 mA |
| Heater voltage | $V_f$ | 3.8 V  |

### DIMENSIONS AND CONNECTIONS

Dimensions in mm

Base: Noval

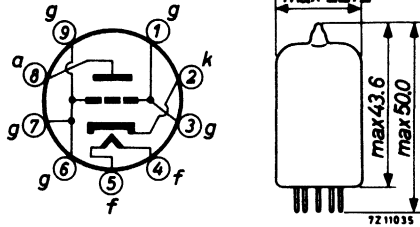

### CAPACITANCES

Without external screen

|               |          |        |
|---------------|----------|--------|
| Anode to grid | $C_{ag}$ | 1.2 pF |
|---------------|----------|--------|

With external screen (inside diameter 22.2 mm)

|                           |            |          |
|---------------------------|------------|----------|
| Anode to grid             | $C_{ag}$   | 1.7 pF   |
| Grid to anode + cathode   | $C_{g/kf}$ | 3.8 pF   |
| Anode to heater + cathode | $C_{a/kf}$ | 0.055 pF |

**TYPICAL CHARACTERISTICS**

|                               |          |                            |
|-------------------------------|----------|----------------------------|
| Anode voltage                 | $V_a$    | 160 V <sup>1)</sup>        |
| Cathode resistor              | $R_k$    | 100 $\Omega$ <sup>1)</sup> |
| Anode current                 | $I_a$    | 12.5 mA                    |
| Transconductance              | $S$      | 13.5 mA/V                  |
| Amplification factor          | $\mu$    | 65                         |
| Equivalent noise resistance   | $R_{eq}$ | 240 $\Omega$               |
| Noise figure at $f = 850$ MHz | $F$      | 10 dB                      |
| Anode voltage                 | $V_a$    | 0 V                        |
| Grid current, positive        | $I_g$    | 0.3 $\mu A$                |
| Grid voltage                  | $-V_g$   | max. 1.3 V                 |

Series resonance frequencies

Measured between a point on the relevant tube pin close to the tube bottom and a point close to the relevant pin on a metal reference plane, placed against the tube bottom.

All the pins, except the relevant one, are connected to the reference plane with a negligible impedance.

The tube is screened by a metal screen with an inside diameter of 22.2 mm placed upon the metal reference plane.

|                             |          |          |
|-----------------------------|----------|----------|
| Heater voltage              | $V_f$    | 0 V      |
| Anode voltage               | $V_a$    | 0 V      |
| Anode resonance frequency   | $f_{oa}$ | 1700 MHz |
| Cathode resonance frequency | $f_{ok}$ | 1000 MHz |

**LIMITING VALUES** (Design centre rating system)

|                                      |          |                          |
|--------------------------------------|----------|--------------------------|
| Anode voltage                        | $V_{a0}$ | max. 550 V               |
|                                      | $V_a$    | max. 175 V               |
| Anode dissipation                    | $W_a$    | max. 2 W                 |
| Cathode current                      | $I_k$    | max. 13 mA               |
| Grid voltage                         | $-V_g$   | max. 50 V                |
| Grid resistor ( $R_k = 100 \Omega$ ) | $R_g$    | max. 1 M $\Omega$        |
| Cathode to heater voltage            | $V_{kf}$ | max. 100 V <sup>1)</sup> |

<sup>1)</sup> To fulfil the modulation hum requirements, the A.C. component should not exceed 50 V<sub>RMS</sub>.

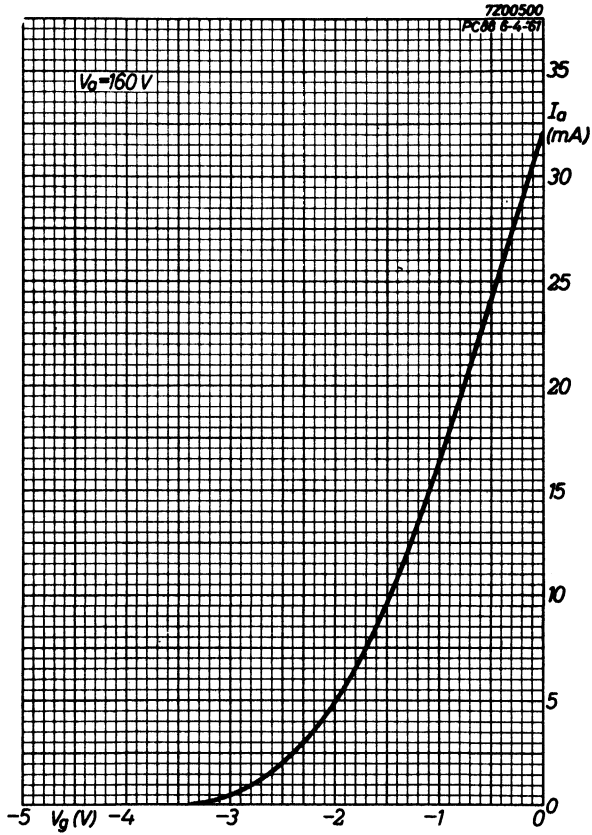

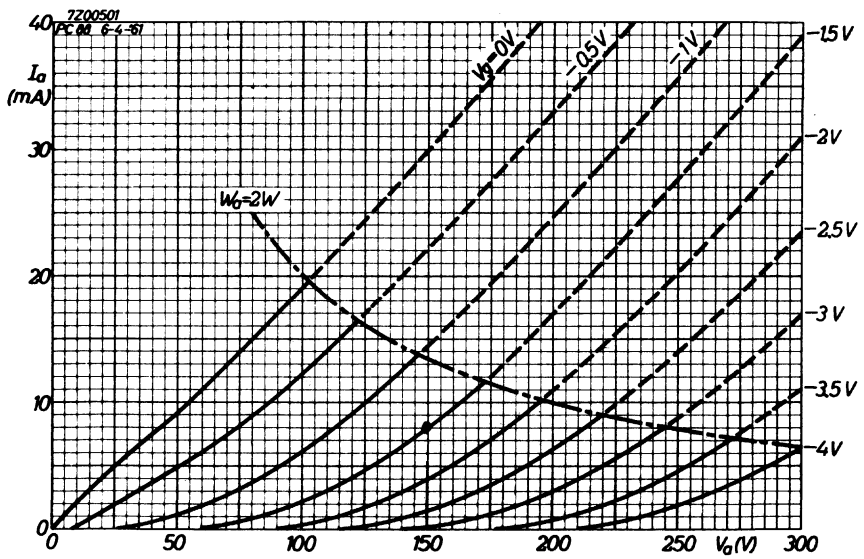



## H.F. TRIODE

Triode intended for use as H.F. amplifier, oscillator, mixer and in frame deflection circuits and line deflection circuits of TV receivers.

| QUICK REFERENCE DATA |       |          |
|----------------------|-------|----------|
| Anode current        | $I_a$ | 12 mA    |
| Transconductance     | $S$   | 7.2 mA/V |
| Amplification factor | $\mu$ | 67 -     |

**HEATING:** Indirect by A.C. or D.C.; series supply

|                |       |        |
|----------------|-------|--------|
| Heater current | $I_f$ | 300 mA |
| Heater voltage | $V_f$ | 3.1 V  |

### DIMENSIONS AND CONNECTIONS

Dimensions in mm

Base: 7 pin miniature

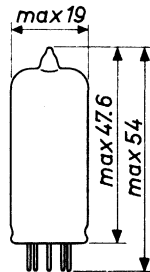
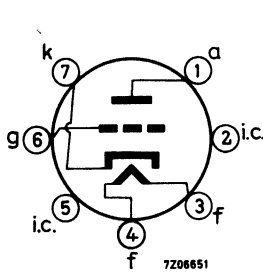



**CAPACITANCES**

Grounded cathode circuit

without external shield

|               |          |         |
|---------------|----------|---------|
| Input         | $C_i$    | 2.8 pF  |
| Output        | $C_o$    | 0.55 pF |
| Anode to grid | $C_{ag}$ | 1.8 pF  |

With external shield 19.5 mm diameter

|                                     |             |        |
|-------------------------------------|-------------|--------|
| Anode to cathode, heater and shield | $C_{a/kfs}$ | 1.4 pF |
| Cathode to grid, heater and shield  | $C_{k/gfs}$ | 4.7 pF |
| Anode to grid, heater and shield    | $C_{a/gfs}$ | 2.9 pF |

Grounded grid circuit

without external shield

|                   |          |              |
|-------------------|----------|--------------|
| Input             | $C_i$    | 4.6 pF       |
| Output            | $C_o$    | 2.0 pF       |
| Anode to cathode  | $C_{ak}$ | 0.24 pF      |
| Cathode to heater | $C_{kf}$ | 2.0 pF       |
| Grid to heater    | $C_{gf}$ | max. 0.15 pF |

**TYPICAL CHARACTERISTICS**

|                             |          |      |      |      |      |            |
|-----------------------------|----------|------|------|------|------|------------|
| Anode voltage               | $V_a$    | 100  | 170  | 200  | 230  | V          |
| Grid voltage                | $V_g$    | -0.9 | -1.0 | -0.9 | -1.6 | V          |
| Anode current               | $I_a$    | 3.0  | 8.5  | 12.0 | 10.5 | mA         |
| Transconductance            | $S$      | 3.8  | 6.0  | 7.2  | 6.0  | mA/V       |
| Amplification factor        | $\mu$    | 58   | 65   | 67   | 62   | -          |
| Equivalent noise resistance | $R_{eq}$ |      | 0.5  | 0.4  | 0.5  | k $\Omega$ |

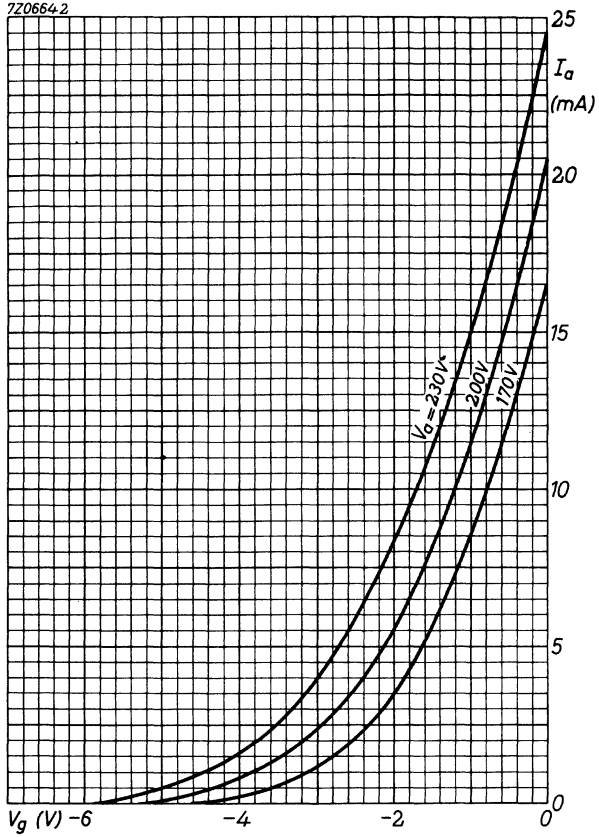

## V.H.F. TRIODE

Triode intended for use as R.F. amplifier in V.H.F. television receivers.

| QUICK REFERENCE DATA |       |            |
|----------------------|-------|------------|
| Cathode current      | $I_k$ | max. 20 mA |
| Transconductance     | S     | 20 mA/V    |
| Amplification factor | $\mu$ | 84         |

**HEATING:** Indirect by A.C. or D.C.; series supply

|                |       |        |
|----------------|-------|--------|
| Heater current | $I_f$ | 300 mA |
| Heater voltage | $V_f$ | 3.9 V  |

### DIMENSIONS AND CONNECTIONS

Dimensions in mm

Base: Miniature 7p

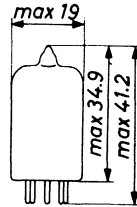
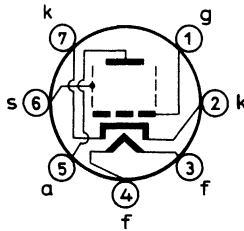

**CAPACITANCES** (with external shield, internal diameter 19.1 mm, connected to cathode)

|                          |            |              |
|--------------------------|------------|--------------|
| Anode to all except grid | $C_{a(g)}$ | 3.0 pF       |
| Grid to all except anode | $C_{g(a)}$ | 4.5 pF       |
| Anode to grid            | $C_{ag}$   | 0.365 pF     |
| Anode to cathode         | $C_{ak}$   | 0.08 pF      |
| Grid to cathode          | $C_{gk}$   | 3.3 pF       |
| Grid to heater           | $C_{gf}$   | max. 0.07 pF |
| Cathode to heater        | $C_{kf}$   | 2.3 pF       |

## TYPICAL CHARACTERISTICS

|                      |       |      |      |       |      |
|----------------------|-------|------|------|-------|------|
| Anode voltage        | $V_a$ | 135  |      |       | V    |
| Shield voltage       | $V_s$ | 0    |      |       | V    |
| Grid voltage         | $V_g$ | -1   | -2.8 | -5.9  | V    |
| Anode current        | $I_a$ | 11.5 | -    | -     | mA   |
| Transconductance     | S     | 14.5 | 1.45 | 0.145 | mA/V |
| Amplification factor | $\mu$ | 76   | -    | -     |      |

## OPERATING CHARACTERISTICS

|                      |                  |       |      |      |            |      |
|----------------------|------------------|-------|------|------|------------|------|
| Anode supply voltage | $V_{ba}$         | 135   | 200  | 200  | V          |      |
| Anode resistor       | $R_a$            | 1.5   | 5.6  | 5.6  | k $\Omega$ |      |
| Shield voltage       | $V_s$            | 0     | 0    | 0    | V          |      |
| Cathode resistor     | $R_k$            | 0     | 0    | 87   | $\Omega$   |      |
| Anode current        | $I_a$            | 16.5  | 16.5 | 11.5 | mA         |      |
| Grid current         | $I_g$            | 20    | 20   | -    | $\mu$ A    |      |
| Transconductance     | S                | 20    | 20   | 14.5 | mA/V       |      |
| Amplification factor | $\mu$            | 84    | 84   | 76   |            |      |
| {                    | Transconductance | S     | 2    | 2    | 1.45       | mA/V |
|                      | Grid voltage     | $V_g$ | -2.3 | -3.2 | -3.8       | V    |
| {                    | Transconductance | S     | 0.2  | 0.2  | 0.145      | mA/V |
|                      | Grid voltage     | $V_g$ | -5.3 | -7.7 | -8.3       | V    |

**LIMITING VALUES** (Design centre rating system)

|                                  |          |                          |
|----------------------------------|----------|--------------------------|
| Anode voltage                    | $V_{a0}$ | max. 550 V               |
|                                  | $V_a$    | max. 200 V               |
| Anode dissipation                | $W_a$    | max. 2.2 W               |
| Cathode current                  | $I_k$    | max. 20 mA               |
| Negative grid voltage            | $-V_g$   | max. 50 V                |
| Grid resistor                    | $R_g$    | max. 1 M $\Omega$        |
| Grid resistor in A.G.C. circuits | $R_g$    | max. 3 M $\Omega$        |
| Cathode to heater voltage        | $V_{kf}$ | max. 100 V <sup>1)</sup> |

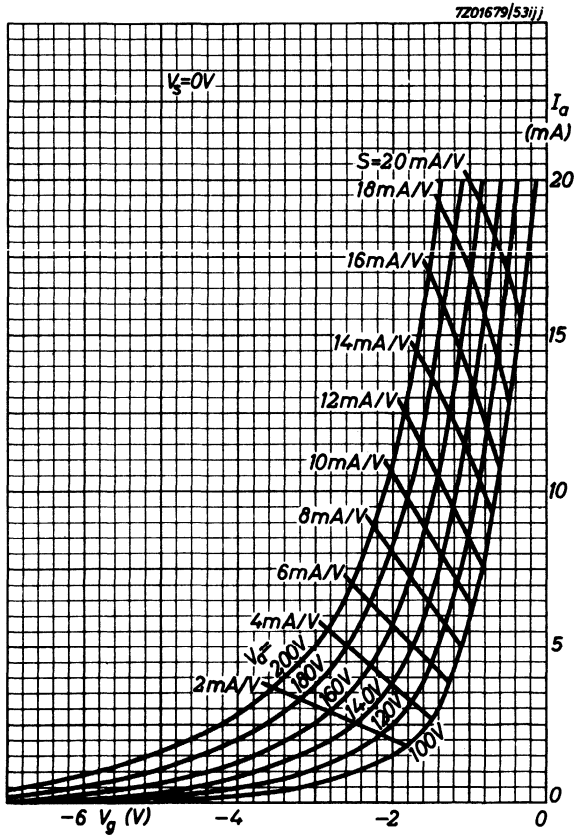

<sup>1)</sup> To fulfil the modulation hum requirements,  $V_{kf}$  should not exceed 55 VRMS.

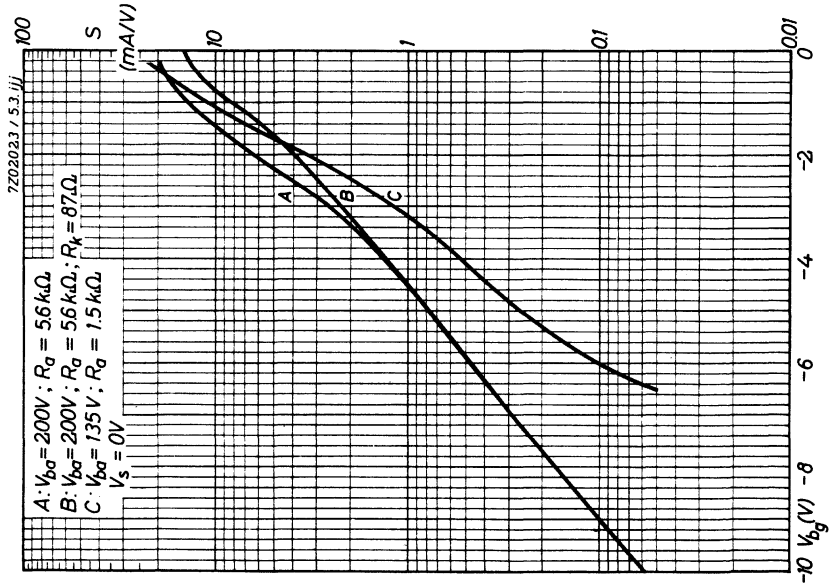
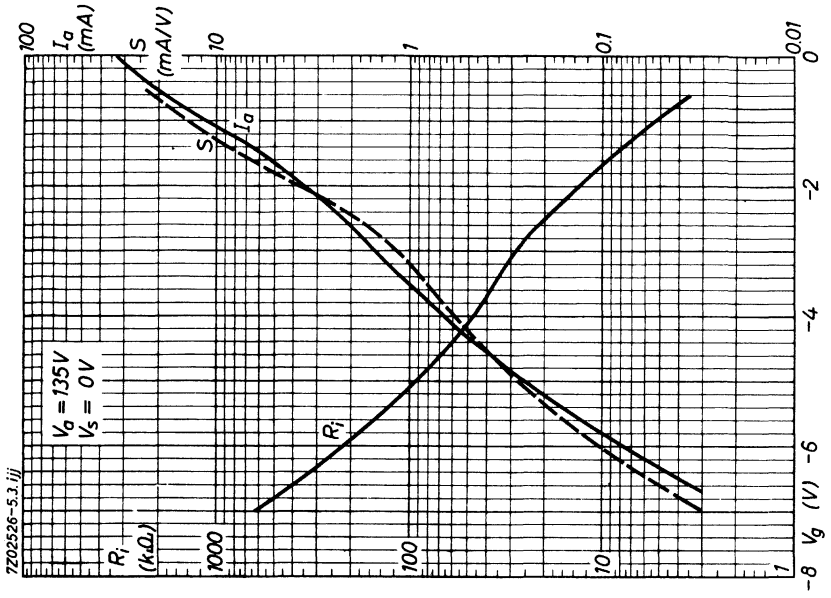



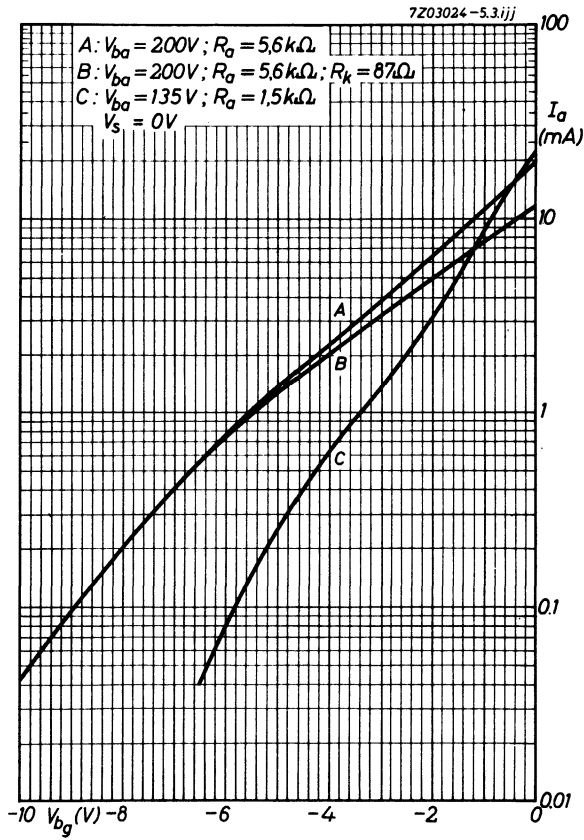

7202525-5.3.ijj

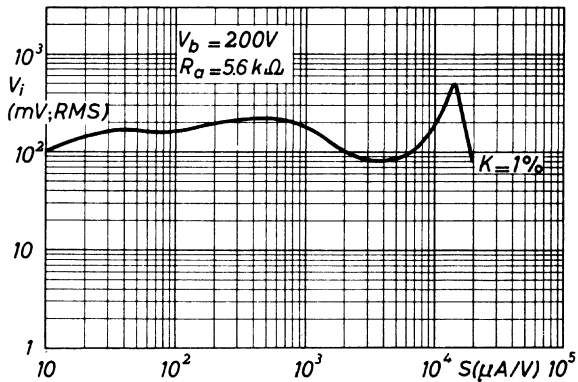
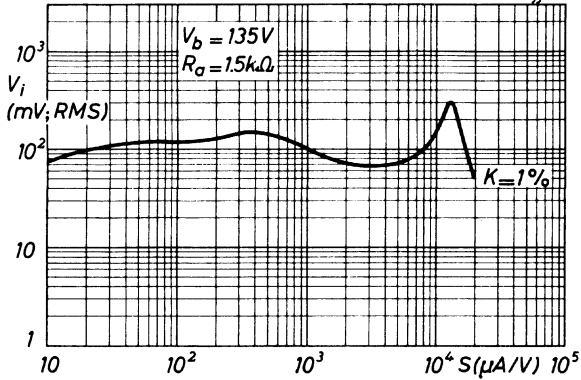

## R.F. DOUBLE TRIODE

Double triode intended for various applications in television receivers.

| QUICK REFERENCE DATA |       |     |      |
|----------------------|-------|-----|------|
| Anode current        | $I_a$ | 10  | mA   |
| Transconductance     | $S$   | 6.7 | mA/V |
| Amplification factor | $\mu$ | 48  | -    |

**HEATING:** Indirect by A.C. or D.C.; series supply

|                |       |     |    |
|----------------|-------|-----|----|
| Heater current | $I_f$ | 300 | mA |
| Heater voltage | $V_f$ | 9.0 | V  |

### DIMENSIONS AND CONNECTIONS

Dimensions in mm

Base: Noval

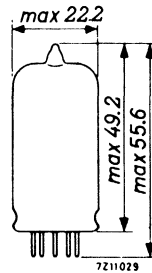
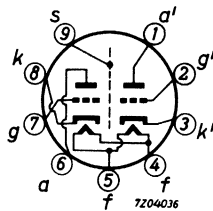

**CAPACITANCES** (each unit unless otherwise specified)

|   |             |            |    |
|---|-------------|------------|----|
| Anode to grid   | $C_{ag}$    | 1.5        | pF |
| Anode to cathode  | $C_{ak}$    | 0.18       | pF |
| Anode to cathode + heater + screen  | $C_{a/kfs}$ | 1.2        | pF |
| Grid to cathode + heater + screen   | $C_{g/kfs}$ | 3.1        | pF |
| Anode to cathode + heater + screen<br>(measured with external screen<br>of 22.5 mm diam.) | $C_{a/kfs}$ | 1.8        | pF |
| Anode to anode other unit   | $C_{aa'}$   | max. 0.04  | pF |
| Anode to anode other unit<br>(measured with external screen<br>of 22.5 mm diam.)          | $C_{aa'}$   | max. 0.008 | pF |
| Grid to grid other unit   | $C_{gg'}$   | max. 0.003 | pF |
| Anode to grid other unit  | $C_{ag'}$   | max. 0.008 | pF |
| Anode to grid other unit  | $C_{a'g}$   | max. 0.008 | pF |
| Anode to cathode other unit   | $C_{ak'}$   | max. 0.008 | pF |
| Anode to cathode other unit   | $C_{a'k}$   | max. 0.008 | pF |
| Grid to cathode other unit  | $C_{gk'}$   | max. 0.003 | pF |
| Grid to cathode other unit  | $C_{g'k}$   | max. 0.003 | pF |

**TYPICAL CHARACTERISTICS** (each unit)

|                      |       |                    |       |      |      |
|----------------------|-------|--------------------|-------|------|------|
| Anode voltage        | $V_a$ | 100                | 170   | 200  | V    |
| Grid voltage         | $V_g$ | -1.2 <sup>1)</sup> | -1.75 | -2.4 | V    |
| Anode current        | $I_a$ | 4.5                | 10    | 10   | mA   |
| Transconductance     | S     | 4.8                | 6.7   | 6    | mA/V |
| Amplification factor | $\mu$ | 46                 | 48    | 46   |      |

**REMARK**

Microphony

This tube can be used without special precautions against microphony in A.F. applications in which the input voltage  $V_i \geq 5$  mV for an output of 50 mW (or 50 mV for an output 5 W) provided the peak acceleration of the tube is not greater than indicated in the section "Microphony" of the "General Operational Recommendations".

<sup>1)</sup> In this case grid current may occur. If this is not permissible, a condition with a bias of -1.5 V should be chosen.

**OPERATING CHARACTERISTICS** (each unit)

As self-oscillating additive mixer

|                                     |            |     |     |     |                  |
|-------------------------------------|------------|-----|-----|-----|------------------|
| Anode supply voltage                | $V_b$      | 100 | 170 | 200 | V                |
| Anode resistor                      | $R_a$      | 4.7 | 4.7 | 8.2 | k $\Omega$       |
| Grid resistor                       | $R_g$      | 1   | 1   | 1   | M $\Omega$       |
| Oscillator voltage                  | $V_{osc.}$ | 1.8 | 2.8 | 2.8 | V <sub>RMS</sub> |
| Anode current                       | $I_a$      | 2.7 | 5.5 | 6   | mA               |
| Conversion conductance              | $S_c$      | 2.2 | 2.8 | 2.9 | mA/V             |
| Internal resistance                 | $R_i$      | 19  | 15  | 14  | k $\Omega$       |
| Grid input resistance (f = 100 MHz) | $r_g$      |     | 15  |     | k $\Omega$       |

As oscillator in television receivers

|                      |            |  |  |     |                  |
|----------------------|------------|--|--|-----|------------------|
| Anode supply voltage | $V_b$      |  |  | 180 | V                |
| Anode resistor       | $R_a$      |  |  | 4.4 | k $\Omega$       |
| Grid resistor        | $R_g$      |  |  | 22  | k $\Omega$       |
| Oscillator voltage   | $V_{osc.}$ |  |  | 9   | V <sub>RMS</sub> |
| Anode current        | $I_a$      |  |  | 7.4 | mA               |
| Anode dissipation    | $W_a$      |  |  | 1.2 | W                |

**LIMITING VALUES** (each unit) (Design centre rating system)

|                           |                |      |     |            |
|---------------------------|----------------|------|-----|------------|
| Anode voltage             | $V_{aO}$       | max. | 550 | V          |
|                           | $V_a$          | max. | 250 | V          |
| Anode dissipation         | $W_a$          | max. | 2.5 | W          |
| Anode dissipation, total  | $W_a + W_{a'}$ | max. | 4.5 | W          |
| Cathode current           | $I_k$          | max. | 15  | mA         |
| Cathode to heater voltage | $V_{kf}$       | max. | 90  | V          |
| Grid voltage, negative    | $-V_g$         | max. | 100 | V          |
| Grid resistor             | $R_g$          | max. | 1   | M $\Omega$ |

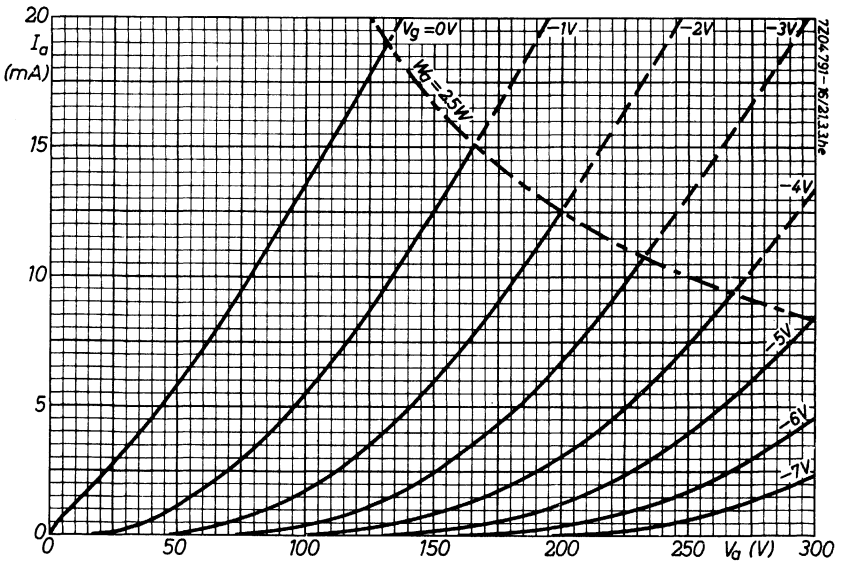
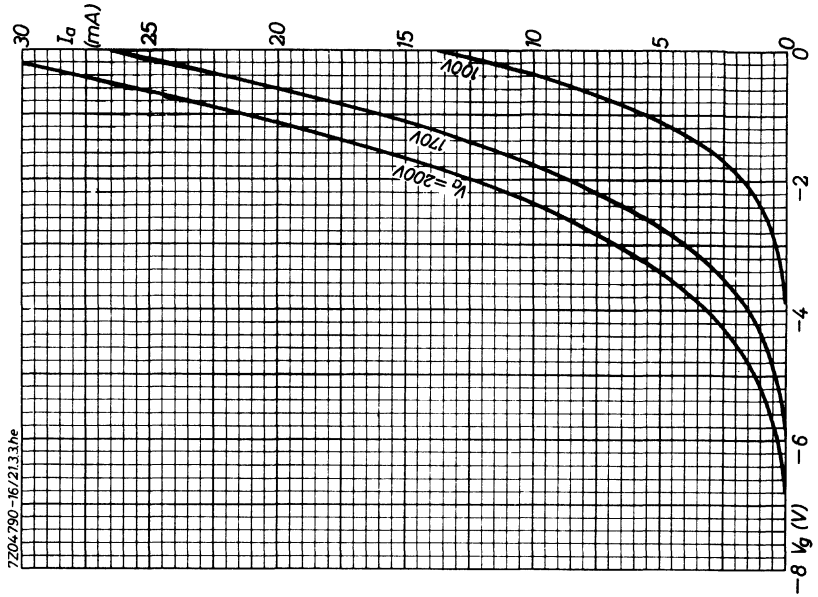

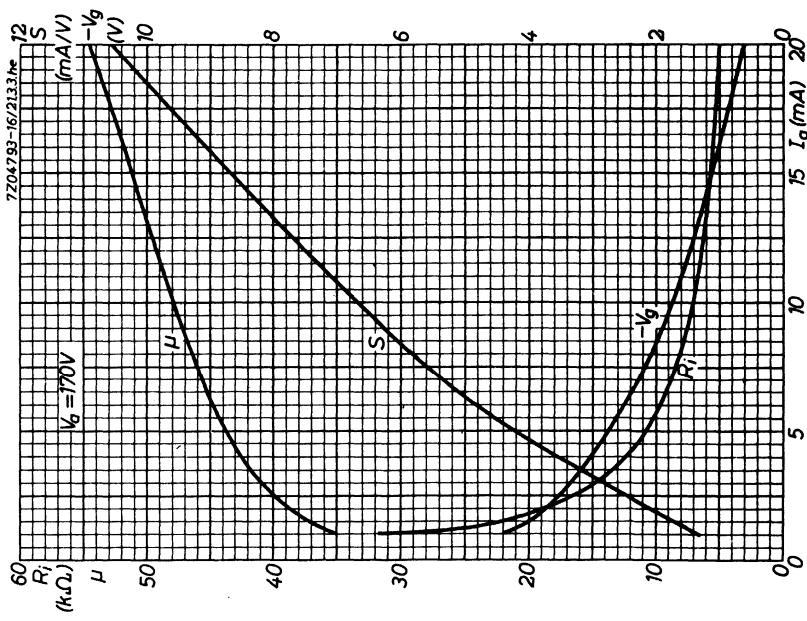
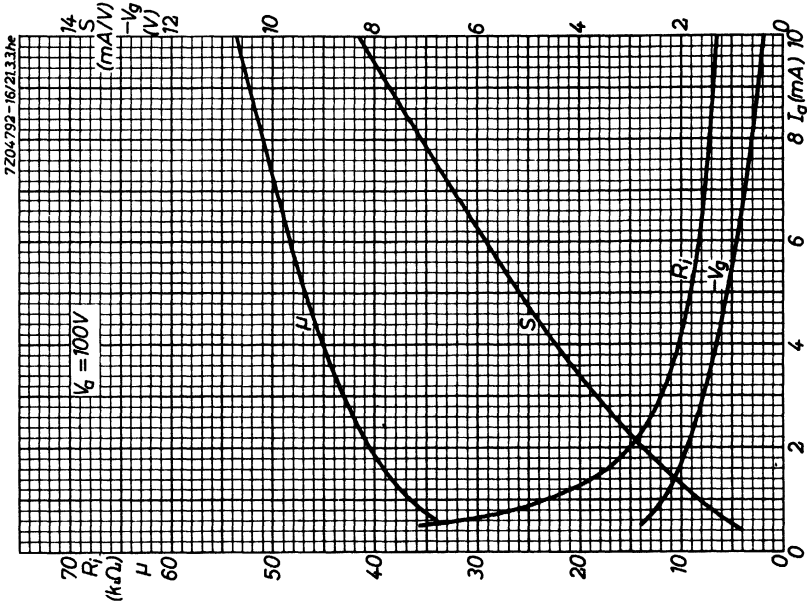

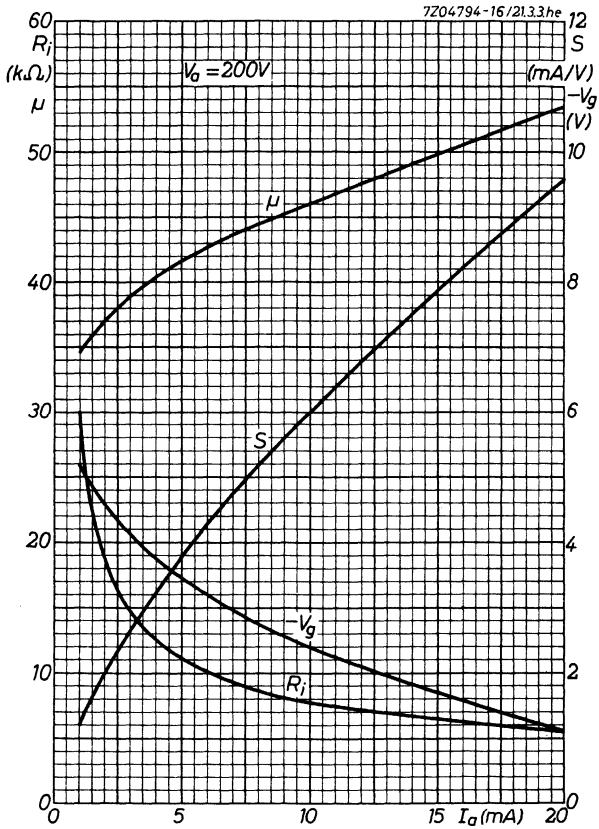



## R.F. DOUBLE TRIODE

Double triode intended for use as cascode amplifier in television tuners.

| QUICK REFERENCE DATA<br>(Each unit) |       |      |      |
|-------------------------------------|-------|------|------|
| Anode current                       | $I_a$ | 15   | mA   |
| Transconductance                    | $S$   | 12.5 | mA/V |
| Amplification factor                | $\mu$ | 33   | -    |

**HEATING:** Indirect by A.C. or D.C.; series supply

Heater current

$I_f$  300 mA

Heater voltage

$V_f$  7.6 V

### DIMENSIONS AND CONNECTIONS

Dimensions in mm

Base: Noval

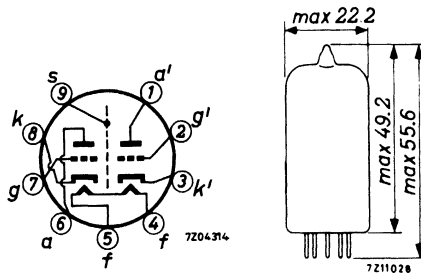

**CAPACITANCES**

|                                    |               | without external<br>screen | with external<br>screen |
|------------------------------------|---------------|----------------------------|-------------------------|
| Anode to grid                      | $C_{ag}$      | 1.4                        | 1.4 pF                  |
| Grid to cathode + heater + screen  | $C_{g/kfs}$   | 3.3                        | 3.3 pF                  |
| Anode to cathode + heater + screen | $C_{a/kfs}$   | 1.8                        | 2.5 pF                  |
| Grid to heater                     | $C_{gf}$      | 0.13                       | 0.13 pF                 |
| Anode to grid                      | $C_{a'g'}$    | 1.4                        | 1.4 pF                  |
| Cathode to grid + heater + screen  | $C_{k'/g'fs}$ | 6                          | 6 pF                    |
| Anode to grid + heater + screen    | $C_{a'/g'fs}$ | 2.8                        | 3.7 pF                  |
| Cathode to heater                  | $C_{k'f}$     | 2.7                        | 2.7 pF                  |
| Anode to cathode                   | $C_{a'k'}$    | 0.18                       | 0.16 pF                 |
| Anode to anode                     | $C_{aa'}$     | max. 0.045                 | max. 0.015 pF           |
| Grid to anode other unit           | $C_{ga'}$     | max. 0.005                 | max. 0.005 pF           |

**REMARK**

The unit a, g, k should be used as the grounded cathode input section and unit a', g', k' as the grounded grid output unit.

**TYPICAL CHARACTERISTICS**

|                             |          |              |
|-----------------------------|----------|--------------|
| Anode voltage               | $V_a$    | 90 V         |
| Grid voltage                | $V_g$    | -1.3 V       |
| Anode current               | $I_a$    | 15 mA        |
| Transconductance            | S        | 12.5 mA/V    |
| Amplification factor        | $\mu$    | 33 -         |
| Equivalent noise resistance | $R_{eq}$ | 300 $\Omega$ |

**LIMITING VALUES** (Design centre rating system) (each unit, unless otherwise stated)

|                           |                  |      |                     |
|---------------------------|------------------|------|---------------------|
| Anode voltage             | $V_{a0}$         | max. | 550 V               |
|                           | $V_a$            | max. | 130 V               |
| Anode dissipation         | $W_a$            | max. | 1.8 W               |
| Cathode current           | $I_k$            | max. | 25 mA               |
| Grid voltage              | $-V_g$           | max. | 50 V                |
| Grid resistor             | $R_g$            | max. | 1 M $\Omega$        |
| Cathode to heater voltage | $V_{kf}$         | max. | 50 V                |
|                           | $V_{k'f(k'pos)}$ | max. | 150 V <sup>1)</sup> |

**REMARK**

In order not to exceed the maximum permissible anode voltage when the cascode amplifier is controlled, it is necessary to use a voltage divider for the grid of the grounded grid section. With grid current biasing for the grounded cathode section the anode voltage across this section should not be more than 75 V in the not controlled condition.

<sup>1)</sup> D.C. component max. 130 V.

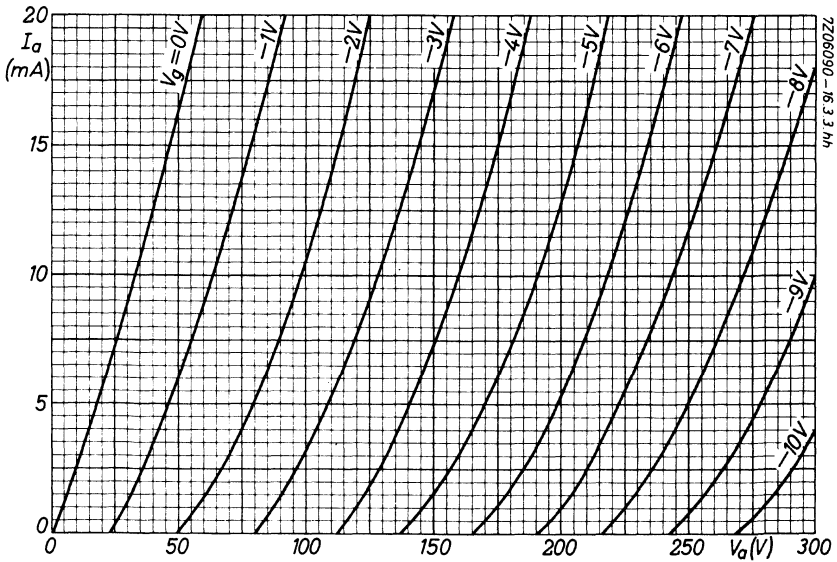
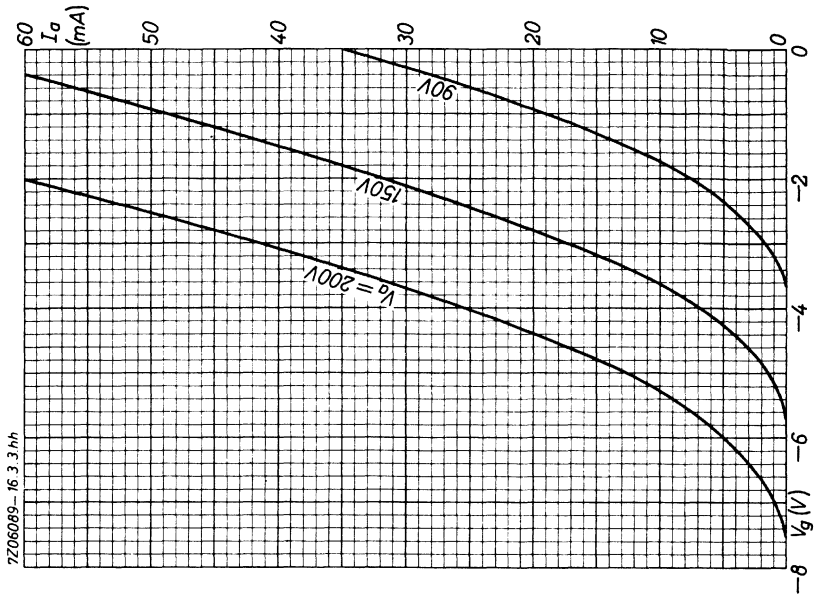

## R.F. DOUBLE TRIODE

Double triode with variable transconductance intended for use as V.H.F. cas-code amplifier in television receivers.

| QUICK REFERENCE DATA |       |           |
|----------------------|-------|-----------|
| Anode current        | $I_a$ | 15 mA     |
| Transconductance     | $S$   | 12.5 mA/V |
| Amplification factor | $\mu$ | 31 -      |

**HEATING:** Indirect by A. C. or D. C.; series supply

Heater current

$I_f$  300 mA

Heater voltage

$V_f$  7.6 V

### DIMENSIONS AND CONNECTIONS

Dimensions in mm

Base: Noval

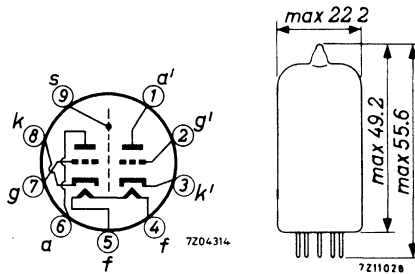

**CAPACITANCES**

|                                    |               | with external screen<br>22.2 mm diam. | without<br>external screen |
|------------------------------------|---------------|---------------------------------------|----------------------------|
| Grid to cathode + heater + screen  | $C_{g/kfs}$   | 3.5                                   | 3.5 pF                     |
| Anode to cathode + heater + screen | $C_{a/kfs}$   | 2.3                                   | 1.7 pF                     |
| Anode to grid                      | $C_{ag}$      | 1.9                                   | 1.9 pF                     |
| Grid to heater                     | $C_{gf}$      | max. 0.28                             | max. 0.28 pF               |
| Cathode to grid + heater + screen  | $C_{k'/g'fs}$ | 6.0                                   | 6.0 pF                     |
| Anode to grid, heater + screen     | $C_{a'/g'fs}$ | 4.0                                   | 3.4 pF                     |
| Anode to cathode                   | $C_{a'k'}$    | 0.17                                  | 0.18 pF                    |
| Cathode to heater                  | $C_{k'f}$     | 2.7                                   | 2.7 pF                     |
| Anode to grid                      | $C_{a'g'}$    | 1.9                                   | 1.9 pF                     |
| Anode to anode                     | $C_{aa'}$     | max. 0.015                            | max. 0.045 pF              |
| Grid to anode other unit           | $C_{ga'}$     | max. 0.004                            | max. 0.004 pF              |

**TYPICAL CHARACTERISTICS** (each unit)

|                     |                  |                |            |
|---------------------|------------------|----------------|------------|
| Anode voltage       | $V_a$            | 90 V           |            |
| Grid voltage        | $V_g$            | -1.4 V         |            |
| Anode current       | $I_a$            | 15 mA          |            |
| Transconductance    | S                | 12.5 mA/V      |            |
| Internal resistance | $R_i$            | 2.5 k $\Omega$ |            |
| {                   | Grid voltage     | $V_g$          | -5 V       |
|                     | Transconductance | S              | 0.625 mA/V |
| {                   | Grid voltage     | $V_g$          | -9 V       |
|                     | Transconductance | S              | 0.125 mA/V |

**LIMITING VALUES** (Design centre rating system) (Each unit)

|                                       |           |      |                     |
|---------------------------------------|-----------|------|---------------------|
| Anode voltage                         | $V_{a_0}$ | max. | 550 V               |
|                                       | $V_a$     | max. | 130 V               |
| Anode dissipation                     | $W_a$     | max. | 1.8 W               |
| Grid voltage                          | $-V_g$    | max. | 50 V                |
| Grid resistor                         |           |      |                     |
| unit a, g, k                          | $R_g$     | max. | 1 M $\Omega$        |
| unit a', g', k'                       | $R_{g'}$  | max. | 0.5 M $\Omega$      |
| Cathode current                       | $I_k$     | max. | 22 mA               |
| Cathode to heater voltage             |           |      |                     |
| unit a, g, k                          | $V_{kf}$  | max. | 80 V                |
| unit a', g', k'<br>(cathode positive) | $V_{k'f}$ | max. | 180 V <sup>1)</sup> |

**REMARKS**

In order not to exceed the maximum permissible anode voltage when the tube is controlled, it is necessary to use a voltage divider for the grid of the grounded grid section.

The system a, g, k should be used as the grounded cathode input section and the system a', g', k' as the grounded grid output section.

<sup>1)</sup> D.C. component max. 130 V.

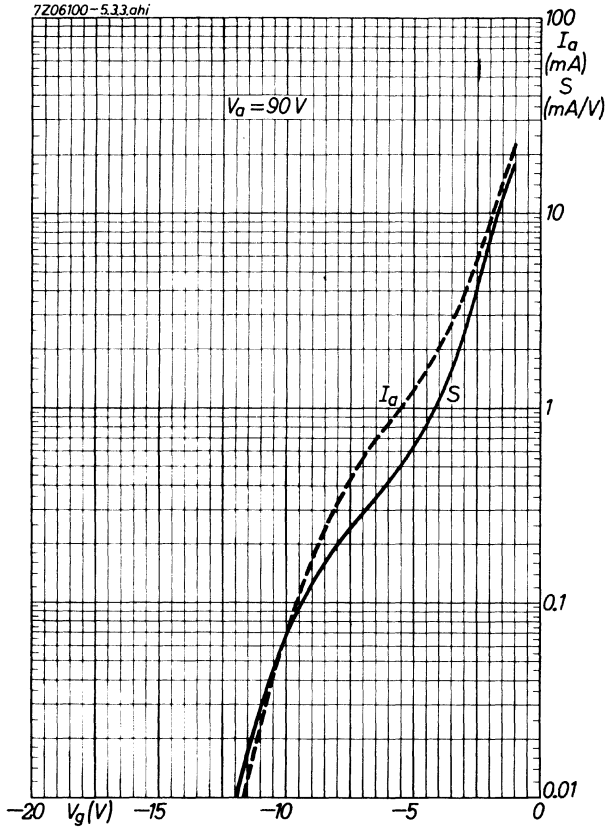



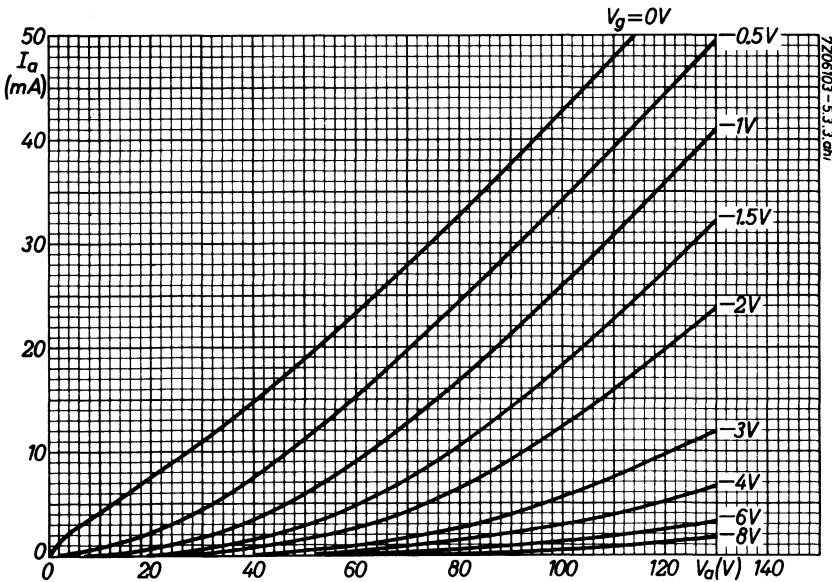
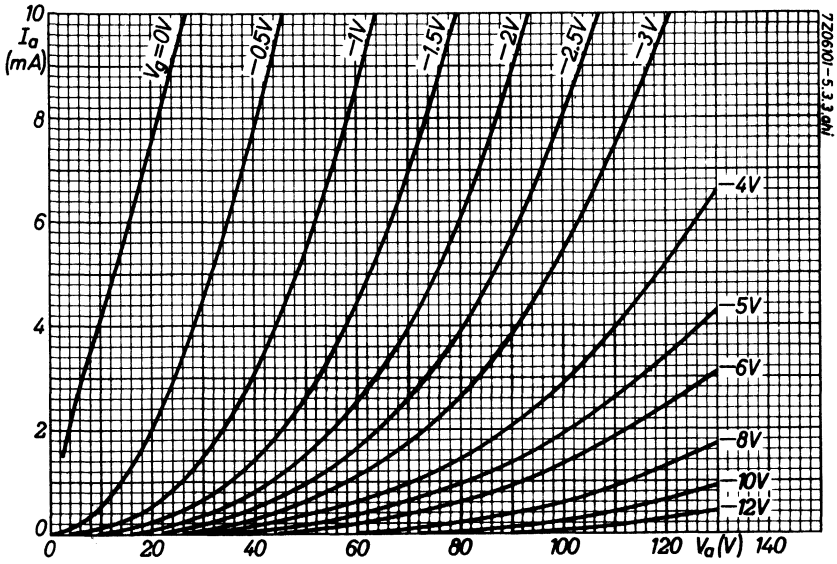

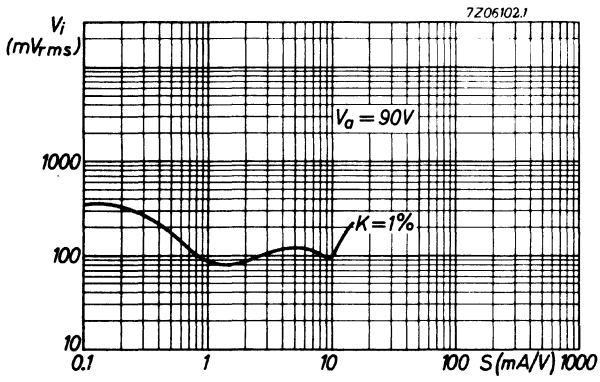

## TRIODE PENTODE

Triode pentode with separate cathodes intended for use as frequency changer in television receivers.

| QUICK REFERENCE DATA   |              |          |
|------------------------|--------------|----------|
| <u>Triode section</u>  |              |          |
| Anode current          | $I_a$        | 14 mA    |
| Transconductance       | S            | 5 mA/V   |
| Amplification factor   | $\mu$        | 20 -     |
| <u>Pentode section</u> |              |          |
| Anode current          | $I_a$        | 10 mA    |
| Transconductance       | S            | 6.2 mA/V |
| Amplification factor   | $\mu_{g2g1}$ | 47 -     |

**HEATING:** Indirect by A.C. or D.C.; series supply

|                |       |        |
|----------------|-------|--------|
| Heater current | $I_f$ | 300 mA |
| Heater voltage | $V_f$ | 9 V    |

### DIMENSIONS AND CONNECTIONS

Dimensions in mm

Base: Noval

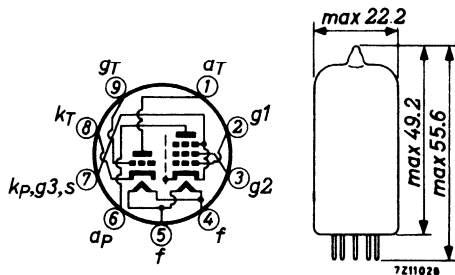

**CAPACITANCES**

Triode section (numbers denote pin number)

|                                      |            |        |
|--------------------------------------|------------|--------|
| Anode to all except grid (1-4+5+7+8) | $C_{a(g)}$ | 1.8 pF |
| Grid to all except anode (9-4+5+7+8) | $C_{g(a)}$ | 2.5 pF |
| Anode to grid                        | $C_{ag}$   | 1.5 pF |

Pentode section

|                               |              |               |
|-------------------------------|--------------|---------------|
| Anode to all except grid No.1 | $C_{a(g_1)}$ | 3.4 pF        |
| Grid No.1 to all except anode | $C_{g_1(a)}$ | 5.2 pF        |
| Anode to grid No.1            | $C_{ag_1}$   | max. 0.025 pF |

Between triode and pentode sections

|                                   |              |              |
|-----------------------------------|--------------|--------------|
| Anode triode to grid No.1 pentode | $C_{aTg_1P}$ | max. 0.16 pF |
| Grid triode to anode pentode      | $C_{gTap}$   | max. 0.02 pF |
| Anode triode to anode pentode     | $C_{aTap}$   | max. 0.07 pF |

**TYPICAL CHARACTERISTICS**

Triode section

|                      |       |        |
|----------------------|-------|--------|
| Anode voltage        | $V_a$ | 100 V  |
| Grid voltage         | $V_g$ | -2 V   |
| Anode current        | $I_a$ | 14 mA  |
| Transconductance     | $S$   | 5 mA/V |
| Amplification factor | $\mu$ | 20 -   |

Pentode section

|   |                |                |
|---|----------------|----------------|
| Anode voltage                             | $V_a$          | 170 V          |
| Grid No.2 voltage                         | $V_{g_2}$      | 170 V          |
| Grid No.1 voltage                         | $V_{g_1}$      | -2 V           |
| Anode current                             | $I_a$          | 10 mA          |
| Grid No.2 current                         | $I_{g_2}$      | 2.8 mA         |
| Transconductance                          | $S$            | 6.2 mA/V       |
| Amplification factor                      | $\mu_{g_2g_1}$ | 47 -           |
| Internal resistance                       | $R_i$          | 0.4 M $\Omega$ |
| Grid No.1 impedance<br>(Frequency 50 MHz) | $r_{g_1}$      | 10 k $\Omega$  |
| Equivalent noise resistance               | $R_{eq}$       | 1.5 k $\Omega$ |

**OPERATING CONDITIONS**

As frequency changer (It is recommended to employ the triode in a Colpitts type of circuit and not in a Hartley type)

|                        |           |     |     |           |
|------------------------|-----------|-----|-----|-----------|
| Anode voltage          | $V_a$     | 170 | 170 | V         |
| Grid No.2 voltage      | $V_{g_2}$ | 170 | 170 | V         |
| Grid No.1 resistor     | $R_{g_1}$ | 0.1 | 0.1 | $M\Omega$ |
| Cathode resistor       | $R_k$     | 330 | 820 | $\Omega$  |
| Oscillator voltage     | $V_{osc}$ | 3.5 | 3.5 | $V_{RMS}$ |
| Anode current          | $I_a$     | 6.5 | 5.2 | mA        |
| Grid No.2 current      | $I_{g_2}$ | 2.0 | 1.5 | mA        |
| Grid No.1 current      | $I_{g_1}$ | 20  | 0   | $\mu A$   |
| Conversion conductance | $S_c$     | 2.2 | 2.1 | mA/V      |
| Internal resistance    | $R_i$     | 800 | 870 | $k\Omega$ |

Frame output application (Optimum peak cathode current of the triode section)

To allow for tube spread, for deterioration during life and for emission drop at underheating the equipment should be so designed that it still operates satisfactorily with a peak cathode current of 100 mA (max. pulse duration 4 % of a cycle, but maximum 0.8 ms). The amplitude of the peak current occurring with new tubes should be limited automatically to this max. value of 100 mA. (E.g. by non-bypassed resistances in the grid lead.)

**LIMITING VALUES** (Design centre rating system)

Triode section

|                           |                |                                       |
|---------------------------|----------------|---------------------------------------|
| Anode voltage             | $V_{a0}$       | max. 550 V                            |
|                           | $V_a$          | max. 250 V                            |
| Anode dissipation         | $W_a$          | max. 1.5 W                            |
| Cathode current           |                |                                       |
| average                   | $I_k$          | max. 14 mA                            |
| peak                      | $I_{kp}$       | see under "frame output applications" |
| Grid resistor             | $R_g$          | max. 0.5 M $\Omega$                   |
| Cathode to heater voltage |                |                                       |
| cathode neg               | $V_{kf}$       | max. 100 V                            |
| cathode pos               | $V_{kf}$       | max. 200 V                            |
|                           | D.C. component | max. 120 V                            |

Pentode section

|                               |                |                     |
|-------------------------------|----------------|---------------------|
| Anode voltage                 | $V_{a0}$       | max. 550 V          |
|                               | $V_a$          | max. 250 V          |
| Grid No.2 voltage             | $V_{g20}$      | max. 550 V          |
| $I_k = 14$ mA                 | $V_{g2}$       | max. 175 V          |
| $I_k = \text{max. } 10$ mA    | $V_{g2}$       | max. 200 V          |
| Anode dissipation             | $W_a$          | max. 1.7 W          |
| Grid No.2 dissipation         |                |                     |
| at $W_a = \text{min. } 1.2$ W | $W_{g2}$       | max. 0.5 W          |
| at $W_a = \text{max. } 1.2$ W | $W_{g2}$       | max. 0.75 W         |
| Cathode current               | $I_k$          | max. 14 mA          |
| Grid resistor                 |                |                     |
| fixed bias                    | $R_{g1}$       | max. 0.5 M $\Omega$ |
| automatic bias                | $R_{g1}$       | max. 1 M $\Omega$   |
| Cathode to heater voltage     |                |                     |
| cathode neg                   | $V_{kf}$       | max. 100 V          |
| cathode pos                   | $V_{kf}$       | max. 200 V          |
|                               | D.C. component | max. 120 V          |

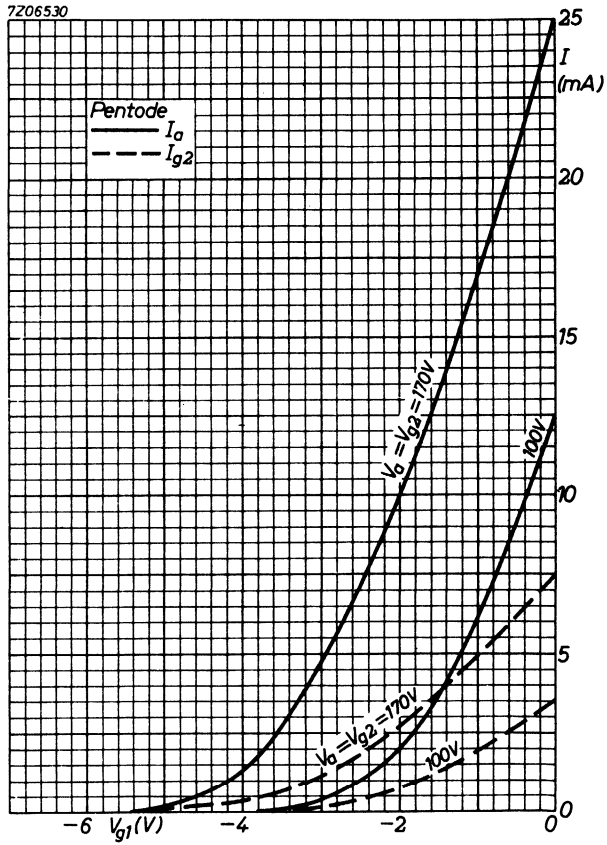

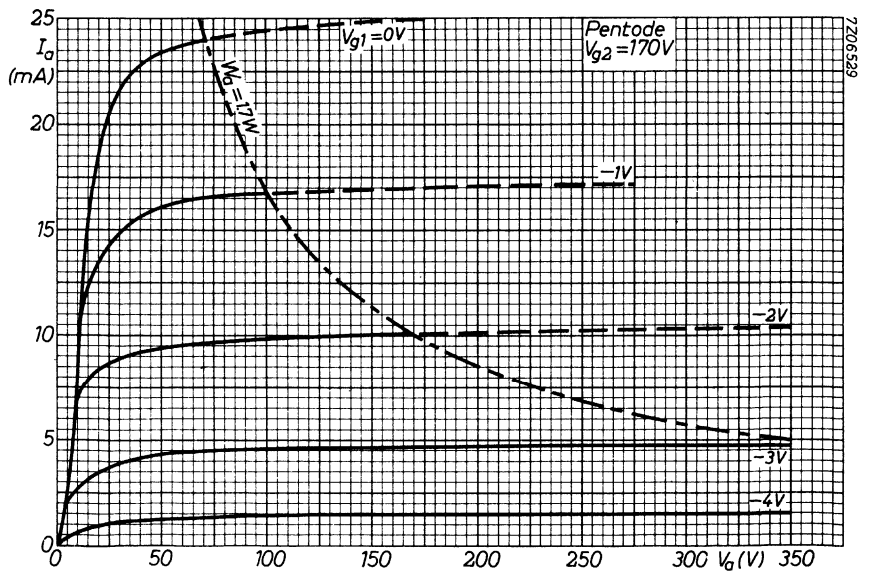
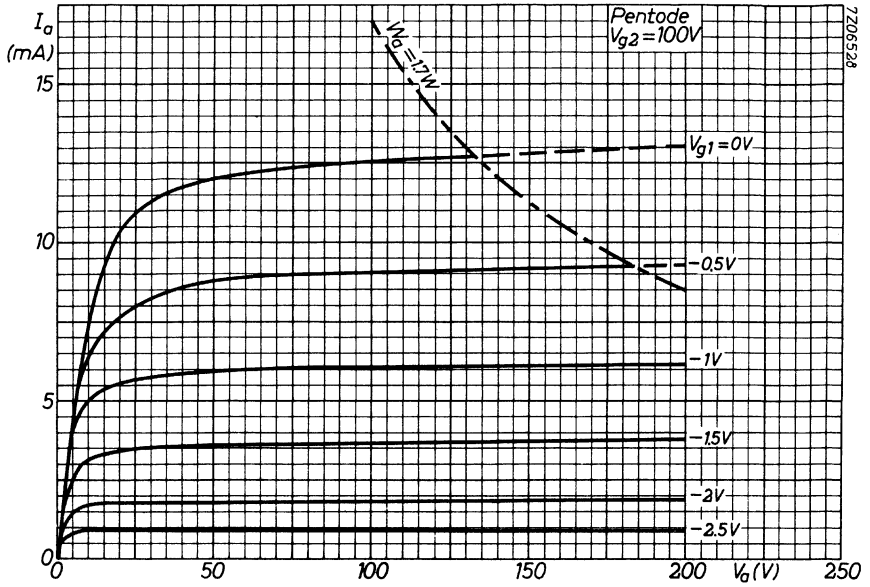



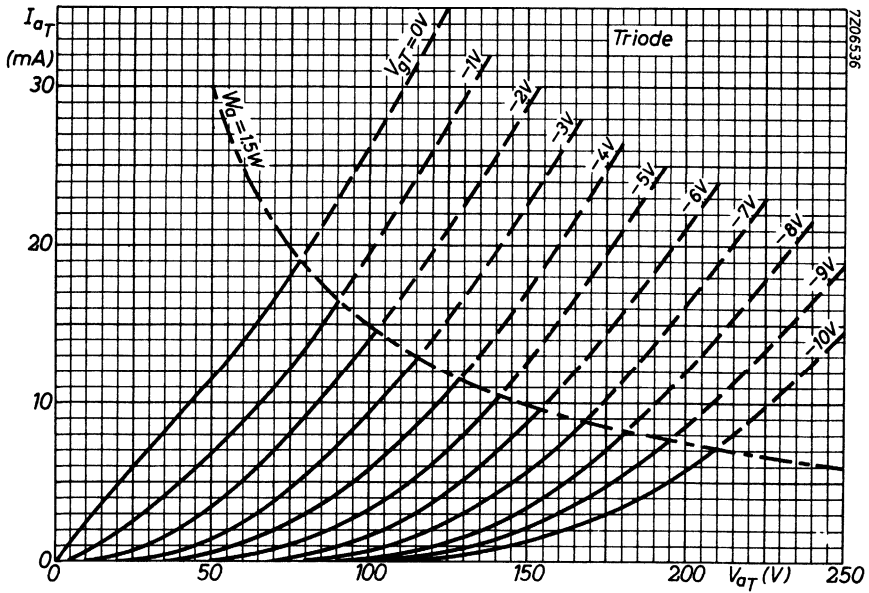
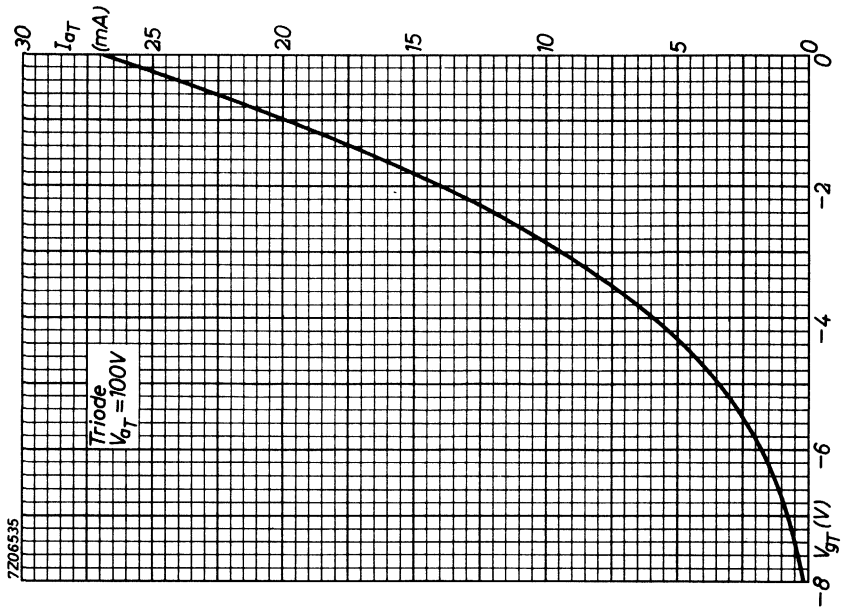

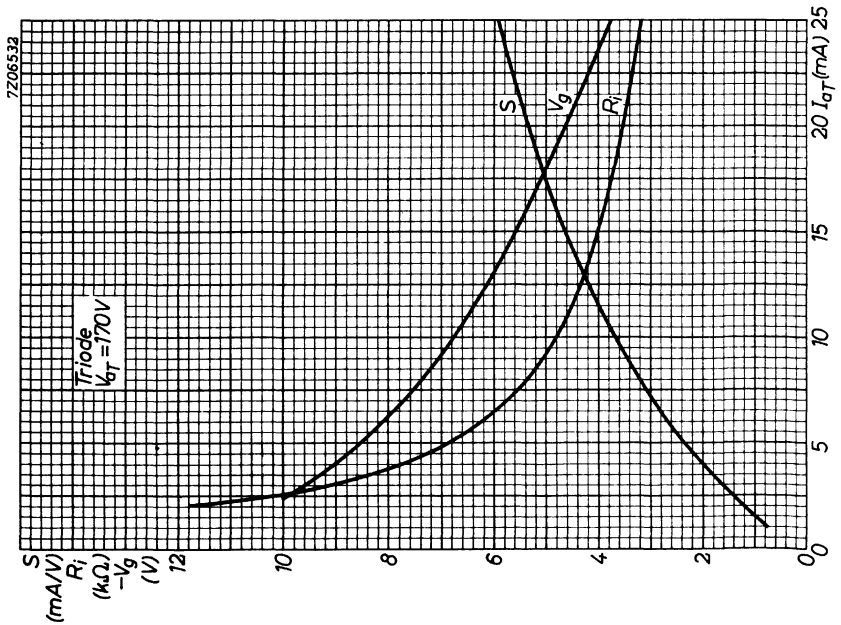
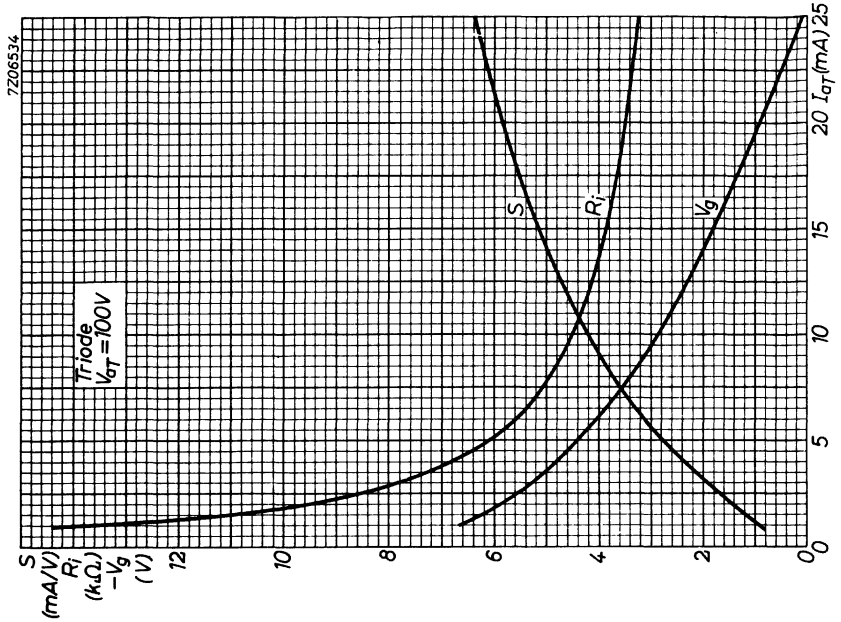

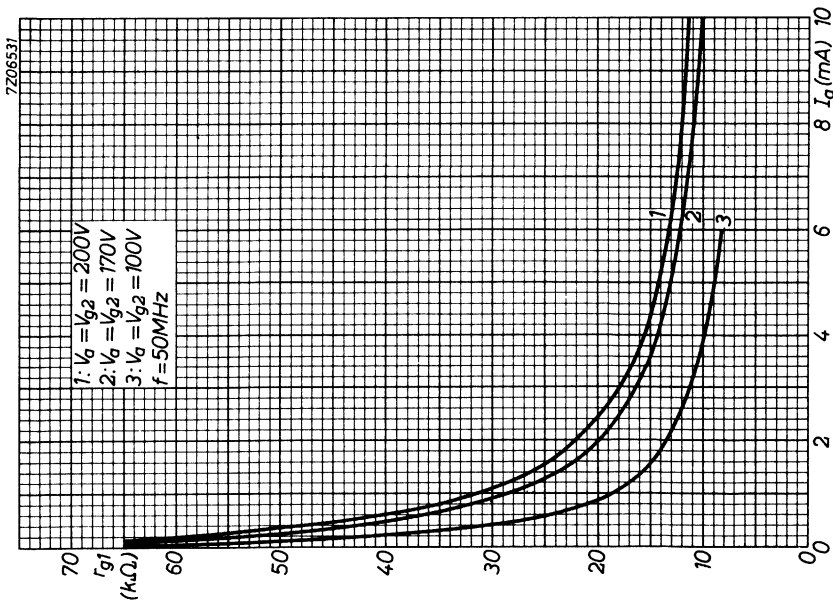
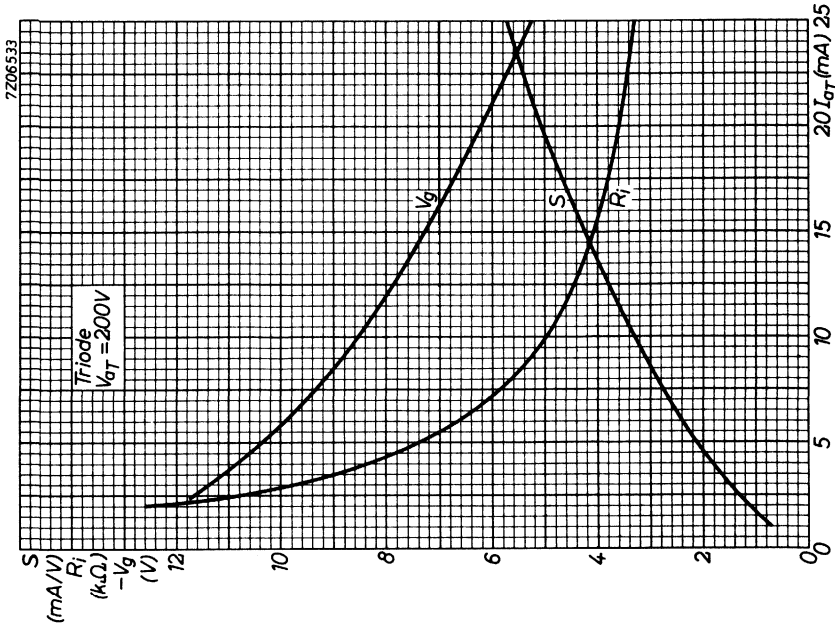



## TRIODE-PENTODE

Triode pentode intended for use as frequency changer in V.H.F. television tuners.

| QUICK REFERENCE DATA   |                |          |
|------------------------|----------------|----------|
| <u>Triode section</u>  |                |          |
| Anode current          | $I_a$          | 14 mA    |
| Transconductance       | $S$            | 5.7 mA/V |
| Amplification factor   | $\mu$          | 17 -     |
| <u>Pentode section</u> |                |          |
| Anode current          | $I_a$          | 10 mA    |
| Transconductance       | $S$            | 12 mA/V  |
| Amplification factor   | $\mu_{g_2g_1}$ | 70 -     |

**HEATING:** Indirect by A.C. or D.C.; series supply

|                |       |        |
|----------------|-------|--------|
| Heater current | $I_f$ | 300 mA |
| Heater voltage | $V_f$ | 8 V    |

### DIMENSIONS AND CONNECTIONS

Dimensions in mm

Base: Noval

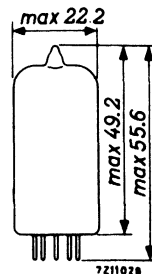
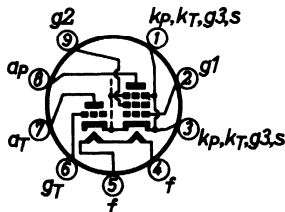

**CAPACITANCES**

Triode section

|                          |            |        |
|--------------------------|------------|--------|
| Anode to all except grid | $C_{a(g)}$ | 1.1 pF |
| Grid to all except anode | $C_{g(a)}$ | 2.4 pF |
| Anode to grid            | $C_{ag}$   | 2.0 pF |

Pentode section

|                                |              |          |
|--------------------------------|--------------|----------|
| Anode to all except grid No. 1 | $C_{a(g_1)}$ | 3.5 pF   |
| Grid No. 1 to all except anode | $C_{g_1(a)}$ | 5.8 pF   |
| Anode to grid No. 1            | $C_{ag_1}$   | 0.012 pF |
| Grid No. 1 to grid No. 2       | $C_{g_1g_2}$ | 1.7 pF   |

Between triode and pentode sections

|                                    |              |               |
|------------------------------------|--------------|---------------|
| Anode triode to anode pentode      | $C_{aTap}$   | 0.125 pF      |
| Grid triode to anode pentode       | $C_{gTap}$   | 0.014 pF      |
| Anode triode to grid No. 1 pentode | $C_{aTg_1P}$ | max. 0.010 pF |
| Grid triode to grid No. 1 pentode  | $C_{gTg_1P}$ | max. 0.010 pF |

**TYPICAL CHARACTERISTICS**

Triode section

|                      |       |          |
|----------------------|-------|----------|
| Anode voltage        | $V_a$ | 100 V    |
| Grid voltage         | $V_g$ | -3 V     |
| Anode current        | $I_a$ | 14 mA    |
| Transconductance     | $S$   | 5.7 mA/V |
| Amplification factor | $\mu$ | 17 -     |

Pentode section

|                             |                |                     |
|-----------------------------|----------------|---------------------|
| Anode voltage               | $V_a$          | 170 V               |
| Grid No. 2 voltage          | $V_{g_2}$      | 150 V               |
| Grid No. 1 voltage          | $V_{g_1}$      | -1.2 V              |
| Anode current               | $I_a$          | 10 mA               |
| Grid No. 2 current          | $I_{g_2}$      | 3.8 mA              |
| Transconductance            | $S$            | 12 mA/V             |
| Amplification factor        | $\mu_{g_2g_1}$ | 70 -                |
| Internal resistance         | $R_i$          | min. 350 k $\Omega$ |
| Equivalent noise resistance | $R_{eq}$       | 1 k $\Omega$        |

**OPERATING CHARACTERISTICS**Triode section as oscillator

|                            |           |                      |
|----------------------------|-----------|----------------------|
| Anode supply voltage       | $V_{ba}$  | 190 V                |
| Anode resistor             | $R_a$     | 8.2 k $\Omega$       |
| Grid resistor              | $R_g$     | 10 k $\Omega$        |
| Oscillator voltage         | $V_{osc}$ | 4.5 V <sub>RMS</sub> |
| Anode current              | $I_a$     | 12 mA                |
| Effective transconductance | $S_{eff}$ | 3.5 mA/V             |

Pentode section as mixer

|                          |           |                      |
|--------------------------|-----------|----------------------|
| Anode supply voltage     | $V_{ba}$  | 190 V                |
| Grid No.2 supply voltage | $V_{bg2}$ | 190 V                |
| Grid No.2 resistor       | $R_{g2}$  | 18 k $\Omega$        |
| Grid No.1 resistor       | $R_{g1}$  | 100 k $\Omega$       |
| Oscillator voltage       | $V_{osc}$ | 2.3 V <sub>RMS</sub> |
| Anode current            | $I_a$     | 8.5 mA               |
| Grid No.2 current        | $I_{g2}$  | 3.0 mA               |
| Grid No.1 current        | $I_{g1}$  | 30 $\mu$ A           |
| Conversion conductance   | $S_c$     | 4.5 mA/V             |
| Internal resistance      | $R_i$     | 0.6 M $\Omega$       |

**LIMITING VALUES**Triode section

|                           |           |                          |
|---------------------------|-----------|--------------------------|
| Anode voltage             | $V_{a_0}$ | max. 550 V               |
|                           | $V_a$     | max. 250 V               |
| Anode dissipation         | $W_a$     | max. 1.5 W               |
| Cathode current           | $I_k$     | max. 15 mA               |
| Grid resistor             | $R_g$     | max. 0.5 M $\Omega$      |
| Cathode to heater voltage | $V_{kf}$  | max. 100 V <sup>1)</sup> |

Pentode section

|                           |               |                          |
|---------------------------|---------------|--------------------------|
| Anode voltage             | $V_{a_0}$     | max. 550 V               |
|                           | $V_a$         | max. 250 V               |
| Grid No.2 voltage         | $V_{g_{2_0}}$ | max. 550 V               |
|                           | $V_{g_2}$     | max. 150 V               |
| Anode dissipation         | $W_a$         | max. 2.0 W               |
| Grid No.2 dissipation     | $W_{g_2}$     | max. 0.5 W               |
| Cathode current           | $I_k$         | max. 18 mA               |
| Grid No.1 resistor        | $R_{g_1}$     | max. 0.5 M $\Omega$      |
| Cathode to heater voltage | $V_{kf}$      | max. 100 V <sup>1)</sup> |

<sup>1)</sup> To fulfil the modulation hum requirements in intercarrier receivers,  $V_{kf}$  should not exceed 75 V<sub>RMS</sub>.

With respect to modulation hum in A.M. sound receivers,  $V_{kf}$  should not exceed 50 V<sub>RMS</sub>.



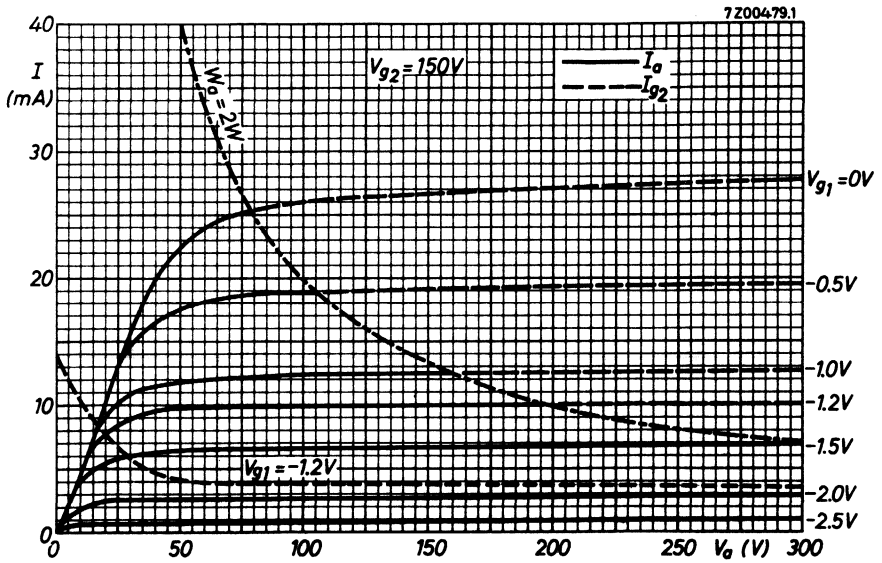

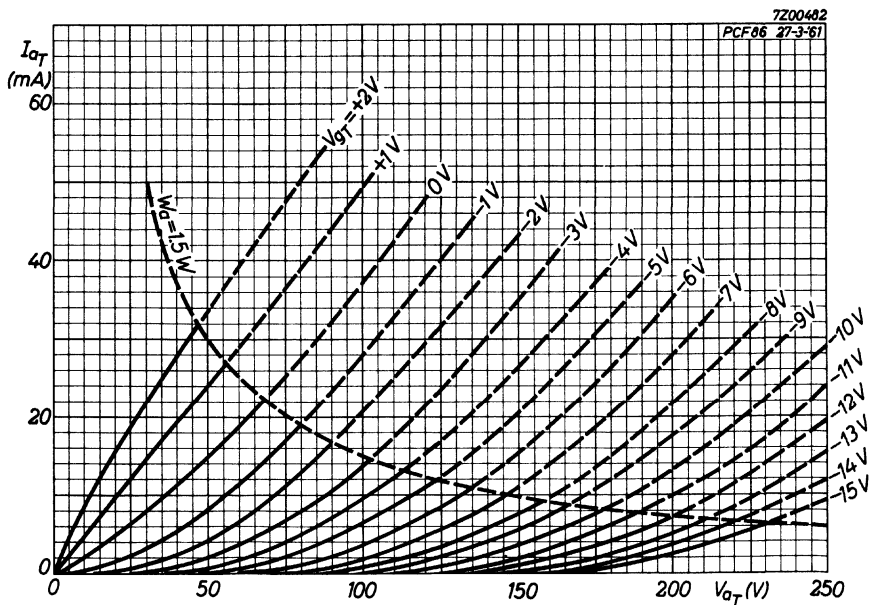
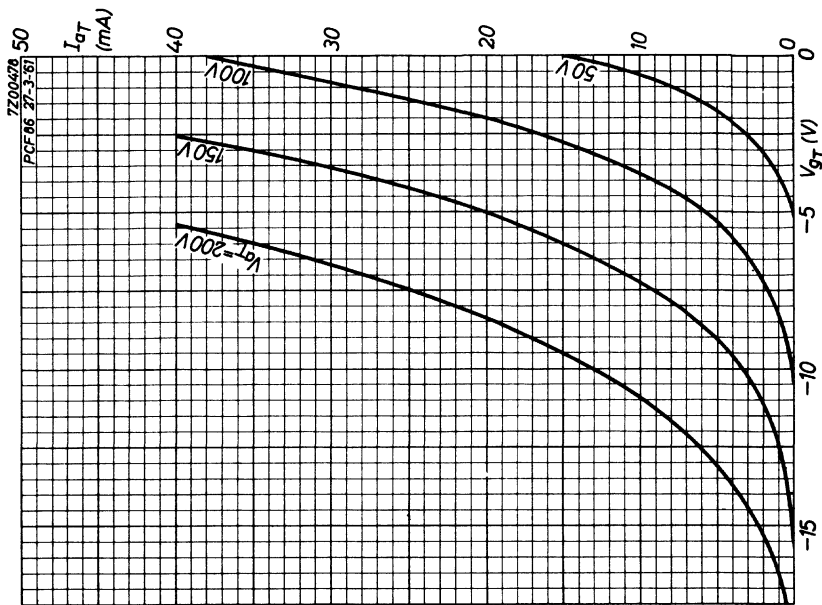

## TRIODE-PENTODE

Triode-pentode intended for use in television receivers; triode section as limiter, noise detector, A.G.C. amplifier, sync. separator and pulse-amplifier; pentode section as sound I.F. amplifier and video I.F. amplifier.

| QUICK REFERENCE DATA   |                |     |      |
|------------------------|----------------|-----|------|
| <u>Pentode section</u> |                |     |      |
| Anode current          | $I_a$          | 13  | mA   |
| Transconductance       | S              | 14  | mA/V |
| Amplification factor   | $\mu_{g_2g_1}$ | 53  | -    |
| <u>Triode section</u>  |                |     |      |
| Anode current          | $I_a$          | 8.5 | mA   |
| Transconductance       | S              | 5.2 | mA/V |
| Amplification factor   | $\mu$          | 57  | -    |

**HEATING:** Indirect by A.C. or D.C.; series supply

|                |       |     |    |
|----------------|-------|-----|----|
| Heater current | $I_f$ | 300 | mA |
| Heater voltage | $V_f$ | 8.5 | V  |

### DIMENSIONS AND CONNECTIONS

Dimensions in mm

Base: Decal

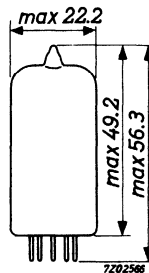
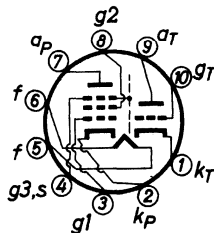

**CAPACITANCES**

Triode section

|                          |            |        |
|--------------------------|------------|--------|
| Grid to all except anode | $C_{g(a)}$ | 2.1 pF |
| Anode to all except grid | $C_{a(g)}$ | 3.0 pF |
| Anode to grid            | $C_{ag}$   | 2.2 pF |

Pentode section

|                               |                 |           |
|-------------------------------|-----------------|-----------|
| Grid No.1 to all except anode | $C_{g_1(a)}$    | 6.0 pF    |
| Anode to all except grid No.1 | $C_{a(g_1)}$    | 3.3 pF    |
| Anode to grid No.1            | $C_{ag_1}$      | 0.0056 pF |
|                               | $C_{ag_1}$ max. | 0.008 pF  |
| Grid No.1 to grid No.2        | $C_{g_1g_2}$    | 1.7 pF    |
| Grid No.1 to cathode          | $C_{g_1k}$      | 3.7 pF    |

Between triode and pentode sections

|                                   |               |                |
|-----------------------------------|---------------|----------------|
| Pentode anode to triode anode     | $C_{aP-aT}$   | max. 0.015 pF  |
| Pentode grid No.1 to triode anode | $C_{g_1P-aT}$ | max. 0.0012 pF |
| Pentode grid No.1 to triode grid  | $C_{g_1P-gT}$ | max. 0.0015 pF |

**TYPICAL CHARACTERISTICS**

Pentode section

|                      |                |         |
|----------------------|----------------|---------|
| Anode voltage        | $V_a$          | 160 V   |
| Grid No.3 voltage    | $V_{g_3}$      | 0 V     |
| Grid No.2 voltage    | $V_{g_2}$      | 135 V   |
| Grid No.1 voltage    | $V_{g_1}$      | -1.7 V  |
| Anode current        | $I_a$          | 13 mA   |
| Grid No.2 current    | $I_{g_2}$      | 5.3 mA  |
| Transconductance     | $S$            | 14 mA/V |
| Amplification factor | $\mu_{g_2g_1}$ | 53 -    |

Triode section

|                      |       |          |
|----------------------|-------|----------|
| Anode voltage        | $V_a$ | 170 V    |
| Grid voltage         | $V_g$ | -1.0 V   |
| Anode current        | $I_a$ | 8.5 mA   |
| Transconductance     | $S$   | 5.2 mA/V |
| Amplification factor | $\mu$ | 57 -     |

## OPERATING CHARACTERISTICS

Pentode section as sound or video I.F. amplifier ( $g_3$  connected to earth)

|                            |           |      |      |           |
|----------------------------|-----------|------|------|-----------|
| Supply voltage             | $V_b$     | 210  | 230  | V         |
| Anode resistor             | $R_a$     | 3.9  | 5.6  | $k\Omega$ |
| Grid No.2 resistor         | $R_{g_2}$ | 15   | 22   | $k\Omega$ |
| Cathode resistor           | $R_k$     | 91   | 83   | $\Omega$  |
| Anode current              | $I_a$     | 13.0 | 12.5 | mA        |
| Grid No.2 current          | $I_{g_2}$ | 5.3  | 5.1  | mA        |
| Transconductance           | S         | 14   | 14   | mA/V      |
| Input resistance at 40 MHz | $r_{g_1}$ | 6.6  | 6.6  | $k\Omega$ |

Triode section as sync separator

|                      |       |            |           |
|----------------------|-------|------------|-----------|
| Anode supply voltage | $V_b$ | 130 to 150 | V         |
| Anode resistor       | $R_a$ | 33         | $k\Omega$ |
| Grid current         | $I_g$ | 1          | $\mu A$   |
| Anode current        | $I_a$ | min. 2     | mA        |

**LIMITING VALUES** (Design centre rating system)

Pentode section

|                           |           |                   |
|---------------------------|-----------|-------------------|
| Anode voltage             | $V_{a0}$  | max. 550 V        |
|                           | $V_a$     | max. 250 V        |
| Anode dissipation         | $W_a$     | max. 2.1 W        |
| Cathode current           | $I_k$     | max. 20 mA        |
| Grid No.2 voltage         | $V_{g20}$ | max. 550 V        |
|                           | $V_{g2}$  | max. 250 V        |
| Grid No.2 dissipation     | $W_{g2}$  | max. 0.75 W       |
| Cathode to heater voltage | $V_{kf}$  | max. 150 V        |
| Grid No.1 resistor        | $R_{g1}$  | max. 1 M $\Omega$ |

Triode section

|   |          |   |
|---|----------|---|
| Peak anode voltage ( $I_a < 0.1$ mA)    | $V_{ap}$ | max. 600 V <sup>1)</sup>                  |
| Anode voltage                           | $V_{a0}$ | max. 550 V                                |
|   | $V_a$    | max. 250 V                                |
| Anode dissipation                       | $W_a$    | max. 1.5 W                                |
| Cathode current                         | $I_k$    | max. 18 mA                                |
| Grid resistor                           | $R_g$    | max. 1 M $\Omega$                         |
| Cathode to heater voltage:              |          |   |
| cathode negative with respect to heater | $V_{kf}$ | max. 150 V                                |
| cathode positive with respect to heater | $V_{kf}$ | max. 200 V<br>+ max. 150 V <sub>RMS</sub> |

<sup>1)</sup> Max. pulse duration is 18 % of a cycle but max. 18  $\mu$ sec.

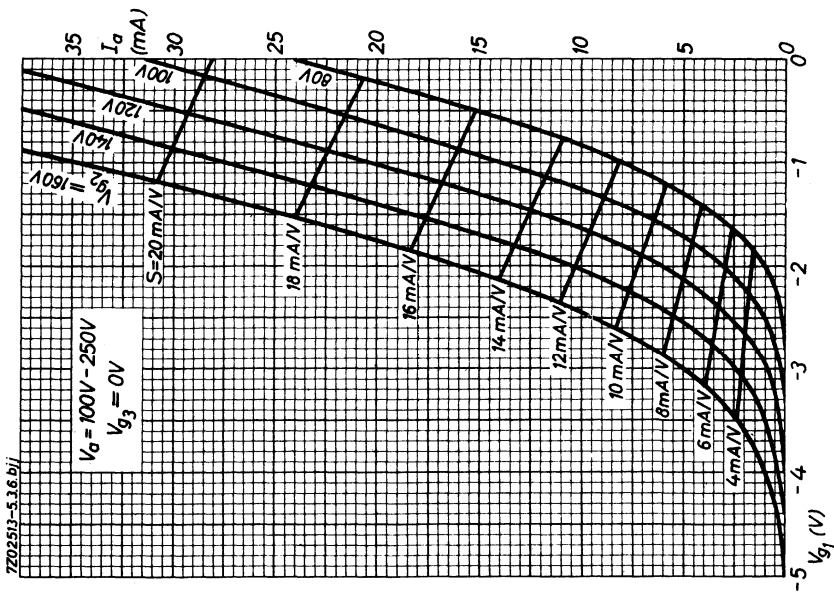
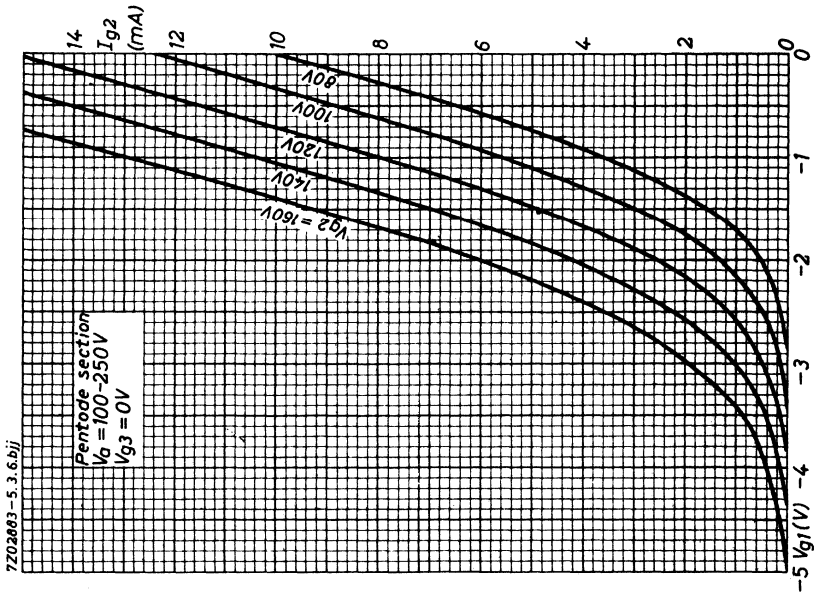

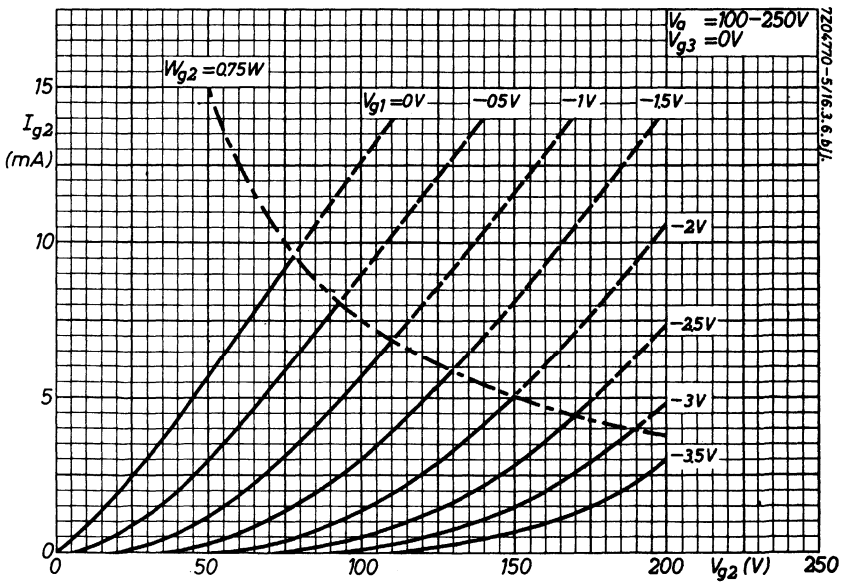
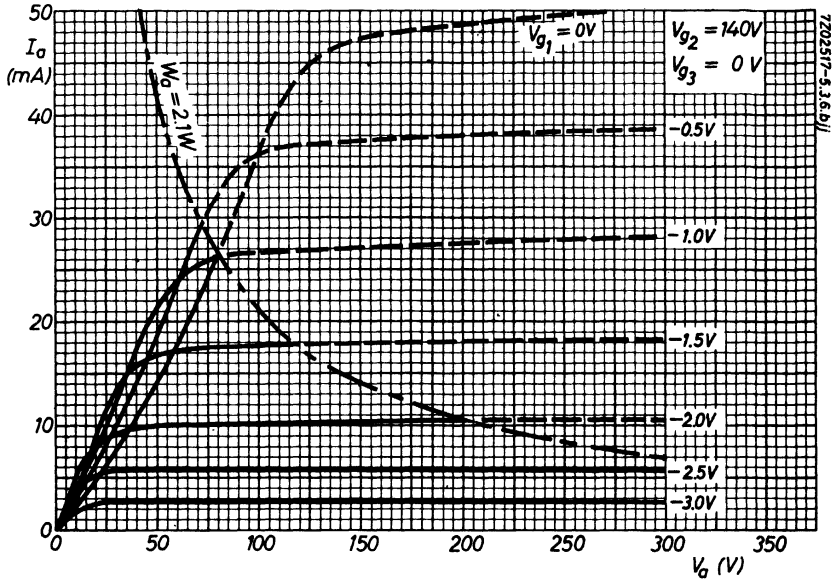



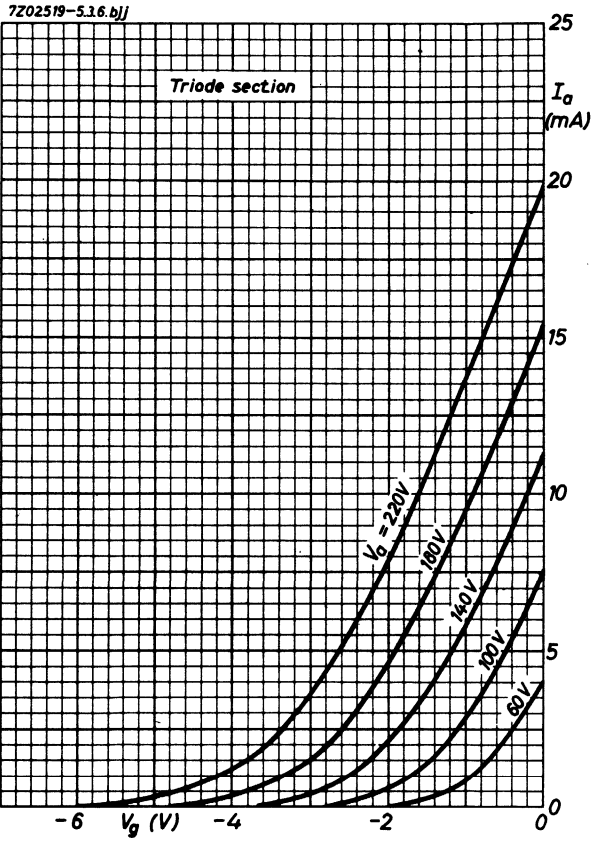

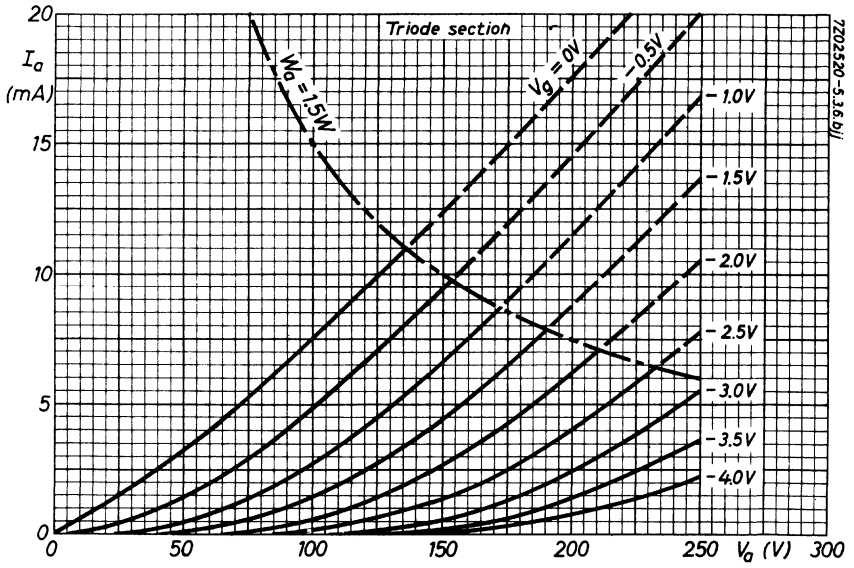

## TRIODE-PENTODE

Triode pentode intended for use in T.V. receivers; triode section as line-blocking oscillator, part of a multivibrator, sync separator, pulse amplifier or A.G.C. delay diode; pentode section with remote cut-off as video I.F. amplifier.

| QUICK REFERENCE DATA   |                |            |
|------------------------|----------------|------------|
| <u>Pentode section</u> |                |            |
| Anode current          | $I_a$          | 13 mA      |
| Transconductance       | S              | 12.6 mA/V  |
| Amplification factor   | $\mu_{g_2g_1}$ | 45 -       |
| <u>Triode section</u>  |                |            |
| Anode current          | $I_a$          | 14 mA      |
| Transconductance       | S              | 4.8 mA/V   |
| Amplification factor   | $\mu$          | 17.5 -     |
| Cathode peak current   | $I_{k_p}$      | max. 50 mA |

**HEATING:** Indirect by A.C. or D.C.; series supply

|                |       |        |
|----------------|-------|--------|
| Heater current | $I_f$ | 300 mA |
| Heater voltage | $V_f$ | 8.5 V  |

### DIMENSIONS AND CONNECTIONS

Dimensions in mm

Base: Decal

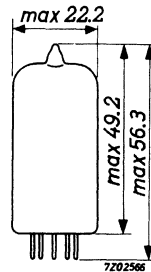
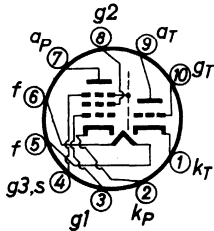

**CAPACITANCES**

Pentode section

|                               |              |               |
|-------------------------------|--------------|---------------|
| Anode to all except grid No.1 | $C_{a(g_1)}$ | 3.3 pF        |
| Grid No.1 to all except anode | $C_{g_1(a)}$ | 6.0 pF        |
| Grid No.1 to cathode          | $C_{kg_1}$   | 3.7 pF        |
| Anode to grid No.1            | $C_{ag_1}$   | 0.0056 pF     |
| Grid No.1 to grid No.2        | $C_{ag_1}$   | max. 0.008 pF |
|                               | $C_{g_1g_2}$ | 1.7 pF        |

Triode section

|                          |            |        |
|--------------------------|------------|--------|
| Anode to all except grid | $C_{a(g)}$ | 3.0 pF |
| Grid to all except anode | $C_{g(a)}$ | 2.1 pF |
| Anode to grid            | $C_{ag}$   | 2.0 pF |

Between pentode and triode sections

|                                   |              |                |
|-----------------------------------|--------------|----------------|
| Pentode anode to triode anode     | $C_{aPaT}$   | max. 0.015 pF  |
| Pentode grid No.1 to triode anode | $C_{g_1PaT}$ | max. 0.0012 pF |
| Pentode grid No.1 to triode grid  | $C_{g_1PgT}$ | max. 0.0015 pF |

**TYPICAL CHARACTERISTICS**

Pentode section

|                      |                |           |
|----------------------|----------------|-----------|
| Anode voltage        | $V_a$          | 160 V     |
| Grid No.3 voltage    | $V_{g_3}$      | 0 V       |
| Grid No.2 voltage    | $V_{g_2}$      | 110 V     |
| Grid No.1 voltage    | $V_{g_1}$      | -1.4 V    |
| Anode current        | $I_a$          | 13 mA     |
| Grid No.2 current    | $I_{g_2}$      | 5.3 mA    |
| Transconductance     | S              | 12.6 mA/V |
| Amplification factor | $\mu_{g_2g_1}$ | 45 -      |

Triode section

|                      |       |          |
|----------------------|-------|----------|
| Anode voltage        | $V_a$ | 100 V    |
| Grid voltage         | $V_g$ | -2 V     |
| Anode current        | $I_a$ | 14 mA    |
| Transconductance     | S     | 4.8 mA/V |
| Amplification factor | $\mu$ | 17.5 -   |

## OPERATING CHARACTERISTICS

Pentode section as video I.F. amplifier ( $g_3$  connected to earth)

|                                      |           |      |       |      |           |
|--------------------------------------|-----------|------|-------|------|-----------|
| Supply voltage                       | $V_b$     | 210  | 230   | 250  | V         |
| Anode resistor                       | $R_a$     | 3.9  | 5.6   | 6.8  | $k\Omega$ |
| Grid No.2 resistor                   | $R_{g_2}$ | 18   | 22    | 27   | $k\Omega$ |
| Cathode resistor                     | $R_k$     | 79   | 79    | 76   | $\Omega$  |
| Anode current                        | $I_a$     | 13.2 | 13.2  | 12.8 | mA        |
| Grid No.2 current                    | $I_{g_2}$ | 5.4  | 5.4   | 5.2  | mA        |
| Transconductance                     | S         | 12.6 | 12.6  | 12.6 | mA/V      |
| Grid No.1 voltage at 0.1 S           | $V_{g_1}$ | -5.1 | -5.4  | -5.7 | V         |
| Grid No.1 voltage at 0.01 S          | $V_{g_1}$ | -19  | -20.5 | -22  | V         |
| Grid No.1 input resistance at 40 MHz | $r_{g_1}$ | 7.4  | 7.4   | 7.4  | $k\Omega$ |

Triode section as line-blocking oscillator

|                      |           |    |    |
|----------------------|-----------|----|----|
| Anode voltage        | $V_a$     | 30 | V  |
| Peak cathode current | $I_{k_p}$ | 40 | mA |
| Peak anode current   | $I_{a_p}$ | 25 | mA |
| Peak grid current    | $I_{g_p}$ | 15 | mA |

Triode section as sync. separator

|                      |           |            |           |
|----------------------|-----------|------------|-----------|
| Anode supply voltage | $V_{b_a}$ | 130 to 150 | V         |
| Anode resistor       | $R_a$     | 33         | $k\Omega$ |
| Grid current         | $I_g$     | 1          | $\mu A$   |
| Anode current        | $I_a$     | min. 2     | mA        |

**LIMITING VALUES** (Design centre rating system)

Pentode section

|                           |              |                   |
|---------------------------|--------------|-------------------|
| Anode voltage             | $V_{a_0}$    | max. 550 V        |
|                           | $V_a$        | max. 250 V        |
| Anode dissipation         | $W_a$        | max. 2.1 W        |
| Grid No.2 voltage         | $V_{g_{20}}$ | max. 550 V        |
|                           | $V_{g_2}$    | max. 250 V        |
| Grid No.2 dissipation     | $W_{g_2}$    | max. 0.7 W        |
| Grid No.1 resistor        | $R_{g_1}$    | max. 1 M $\Omega$ |
| Cathode current           | $I_k$        | max. 20 mA        |
| Cathode to heater voltage | $V_{kf}$     | max. 150 V        |

Triode section

|                           |           |                          |
|---------------------------|-----------|--------------------------|
| Anode voltage             | $V_{a_0}$ | max. 550 V               |
|                           | $V_a$     | max. 250 V               |
| Anode dissipation         | $W_a$     | max. 1.5 W               |
| Grid resistor             | $R_g$     | max. 1 M $\Omega$        |
| Cathode current           | $I_k$     | max. 18 mA               |
| Peak cathode current      | $I_{kp}$  | max. 50 mA <sup>1)</sup> |
| Cathode to heater voltage | $V_{kf}$  | max. 150 V               |

<sup>1)</sup> Maximum pulse duration 10% of a cycle but max. 10  $\mu$ s.

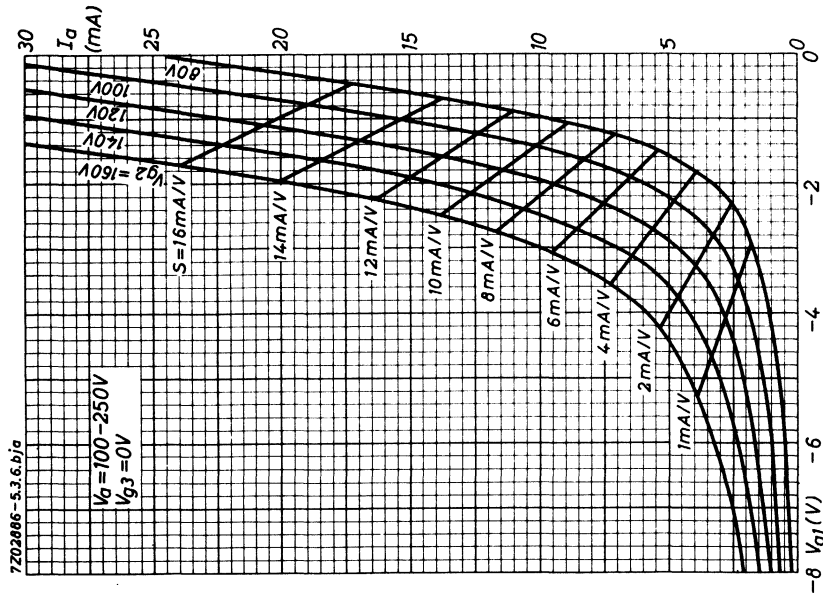
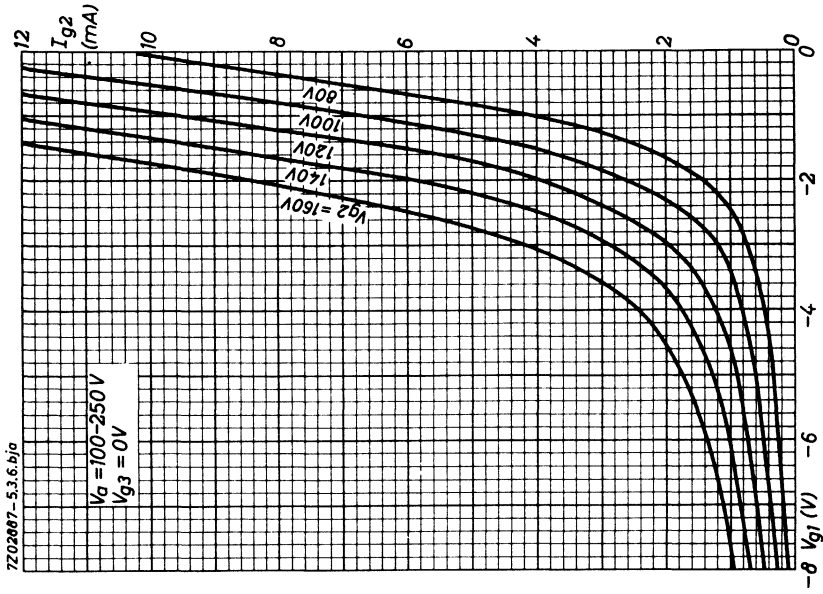

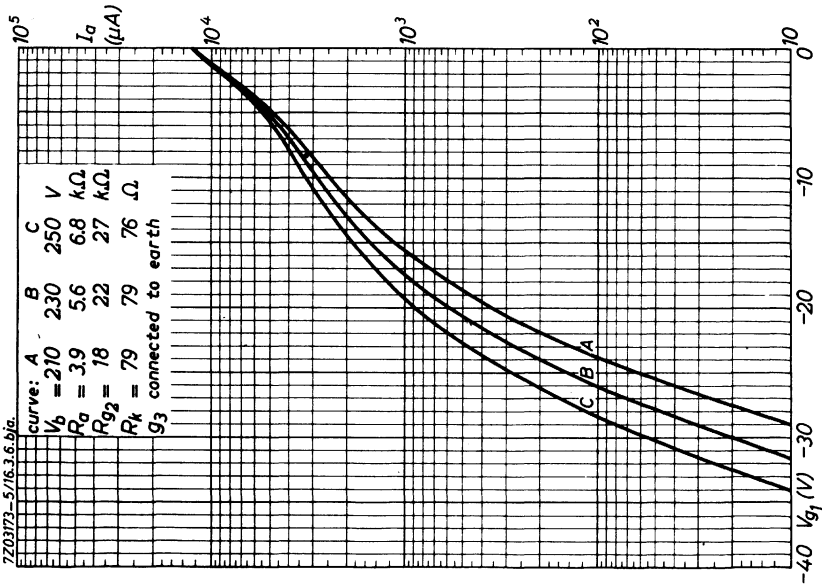
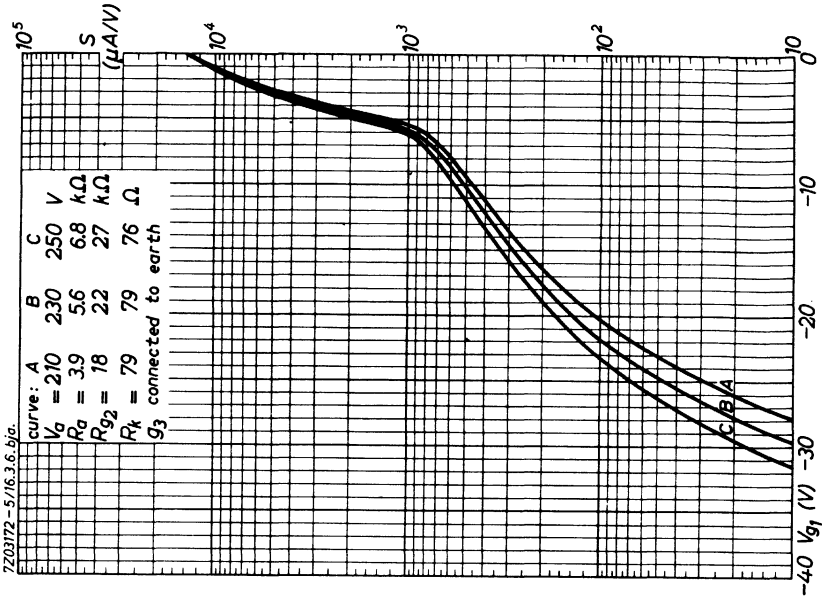



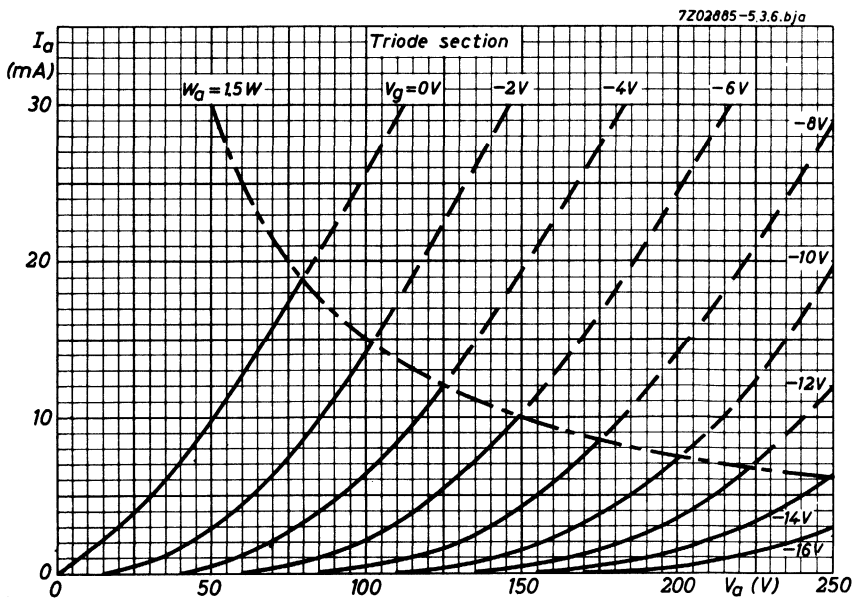
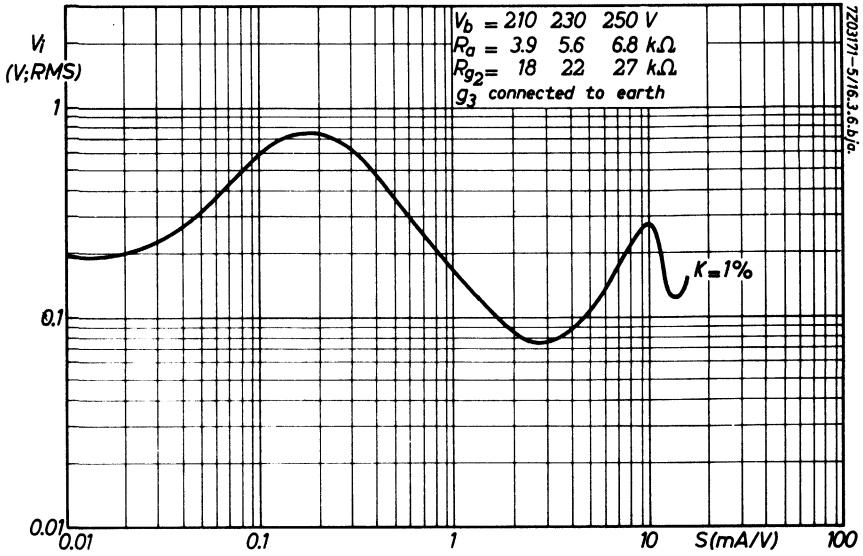

7202884-5.3.6.bja

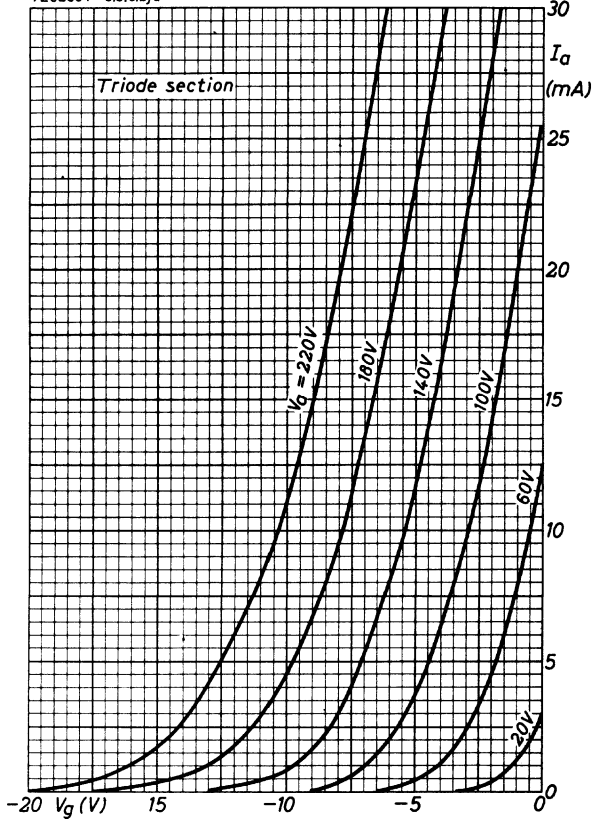

## TRIODE-PENTODE

High transconductance triode and R.F. pentode intended for use as frequency changer in V.H.F. T.V. tuners.

| QUICK REFERENCE DATA   |                |                     |
|------------------------|----------------|---------------------|
| <u>Pentode section</u> |                |                     |
| Anode current          | $I_a$          | 10 mA               |
| Transconductance       | S              | 11 mA/V             |
| Amplification factor   | $\mu_{g_2g_1}$ | 55 -                |
| Internal resistance    | $R_i$          | min. 350 k $\Omega$ |
| <u>Triode section</u>  |                |                     |
| Anode current          | $I_a$          | 15 mA               |
| Transconductance       | S              | 9 mA/V              |
| Amplification factor   | $\mu$          | 20 -                |

**HEATING:** Indirect by A.C. or D.C.; series supply

|                |       |       |
|----------------|-------|-------|
| Heater current | $I_f$ | 0.3 A |
| Heater voltage | $V_f$ | 8.5 V |

### DIMENSIONS AND CONNECTIONS

Dimensions in mm

Base: Noval

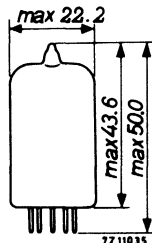
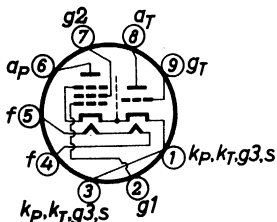

**CAPACITANCES** (with external shield)

Pentode section

|                               |             |               |
|-------------------------------|-------------|---------------|
| Grid No.1 to all except anode | $C_{g1(a)}$ | 5.9 pF        |
| Anode to all except grid No.1 | $C_{a(g1)}$ | 3.7 pF        |
| Anode to grid No.1            | $C_{ag1}$   | 0.009 pF      |
|                               | $C_{ag1}$   | max. 0.012 pF |
| Grid No.1 to grid No.2        | $C_{g1g2}$  | 1.6 pF        |

Triode section

|                          |          |        |
|--------------------------|----------|--------|
| Grid to all except anode | $C_g(a)$ | 3.3 pF |
| Anode to all except grid | $C_a(g)$ | 1.7 pF |
| Anode to grid            | $C_{ag}$ | 1.8 pF |

Between pentode and triode sections

|                                   |             |               |
|-----------------------------------|-------------|---------------|
| Pentode anode to triode anode     | $C_{aPaT}$  | max. 0.025 pF |
| Pentode anode to triode grid      | $C_{aPgT}$  | max. 0.010 pF |
| Pentode grid No.1 to triode anode | $C_{g1PaT}$ | max. 0.010 pF |
| Pentode grid No.1 to triode grid  | $C_{g1PgT}$ | max. 0.010 pF |

**TYPICAL CHARACTERISTICS**

Pentode section

|                             |              |                     |
|-----------------------------|--------------|---------------------|
| Anode voltage               | $V_a$        | 170 V               |
| Grid No.2 voltage           | $V_{g2}$     | 120 V               |
| Grid No.1 voltage           | $V_{g1}$     | -1.4 V              |
| Anode current               | $I_a$        | 10 mA               |
| Grid No.2 current           | $I_{g2}$     | 3 mA                |
| Transconductance            | $S$          | 11 mA/V             |
| Internal resistance         | $R_i$        | min. 350 k $\Omega$ |
| Amplification factor        | $\mu_{g2g1}$ | 55                  |
| Equivalent noise resistance | $R_{eq}$     | 1.5 k $\Omega$      |

**TYPICAL CHARACTERISTICS (continued)**

Triode section

|                      |       |     |      |
|----------------------|-------|-----|------|
| Anode voltage        | $V_a$ | 100 | V    |
| Grid voltage         | $V_g$ | -3  | V    |
| Anode current        | $I_a$ | 15  | mA   |
| Transconductance     | S     | 9   | mA/V |
| Amplification factor | $\mu$ | 20  | -    |

**OPERATING CHARACTERISTICS**

Pentode section as I.F. amplifier

|                            |           |      |                |
|----------------------------|-----------|------|----------------|
| Anode supply voltage       | $V_{ba}$  | 200  | V              |
| Grid No.2 supply voltage   | $V_{bg2}$ | 200  | V              |
| Grid No.2 resistor         | $R_{g2}$  | 27   | k $\Omega$     |
| Anode resistor             | $R_a$     | 2.7  | 4.7 k $\Omega$ |
| Grid No.1 supply voltage   | $V_{bg1}$ | -1.4 | 0 V            |
| Grid No.1 resistor         | $R_{g1}$  | 0.1  | 1 M $\Omega$   |
| Anode current              | $I_a$     | 10   | 13 mA          |
| Grid No.2 current          | $I_{g2}$  | 3.0  | 3.9 mA         |
| Transconductance           | S         | 11   | 14.5 mA/V      |
| Input resistance at 50 MHz | $r_{g1}$  | 10   | 10 k $\Omega$  |
| Grid No.1 voltage          | $V_{g1}$  | -12  | - V            |
| Transconductance           | S         | 0.11 | - mA/V         |

**OPERATING CHARACTERISTICS (continued)**

Pentode section as mixer

|                          |           |      |               |
|--------------------------|-----------|------|---------------|
| Anode supply voltage     | $V_{ba}$  | 200  | V             |
| Grid No.2 supply voltage | $V_{bg2}$ | 200  | V             |
| Grid No.2 resistor       | $R_{g2}$  | 27   | $k\Omega$     |
| Anode resistor           | $R_a$     | 2.7  | 4.7 $k\Omega$ |
| Grid No.1 supply voltage | $V_{bg1}$ | -1.4 | 0 V           |
| Grid No.1 resistor       | $R_{g1}$  | 0.1  | 1 $M\Omega$   |
| Oscillator voltage       | $V_{osc}$ | 1.6  | 1.6 V(RMS)    |
| Anode current            | $I_a$     | 10   | 9.3 mA        |
| Grid No.2 current        | $I_{g2}$  | 3.0  | 2.9 mA        |
| Grid No.1 current        | $I_{g1}$  | 8    | 2.3 $\mu A$   |
| Conversion conductance   | $S_c$     | 5    | 4.7 mA/V      |

**OPERATING CHARACTERISTICS**

Triode section as oscillator

|  |           |     |              |
|--|-----------|-----|--------------|
| Anode supply voltage                                     | $V_{ba}$  | 200 | V            |
| Grid resistor  | $R_g$     | 10  | $k\Omega$    |
| Anode resistor   | $R_a$     | 8.2 | 12 $k\Omega$ |
| Oscillator voltage                                       | $V_{osc}$ | 4.5 | 3.3 V(RMS)   |
| Anode current  | $I_a$     | 16  | 12 mA        |
| Effective transconductance<br>(without higher harmonics) | $S_{eff}$ | 3.7 | 3.7 mA/V     |



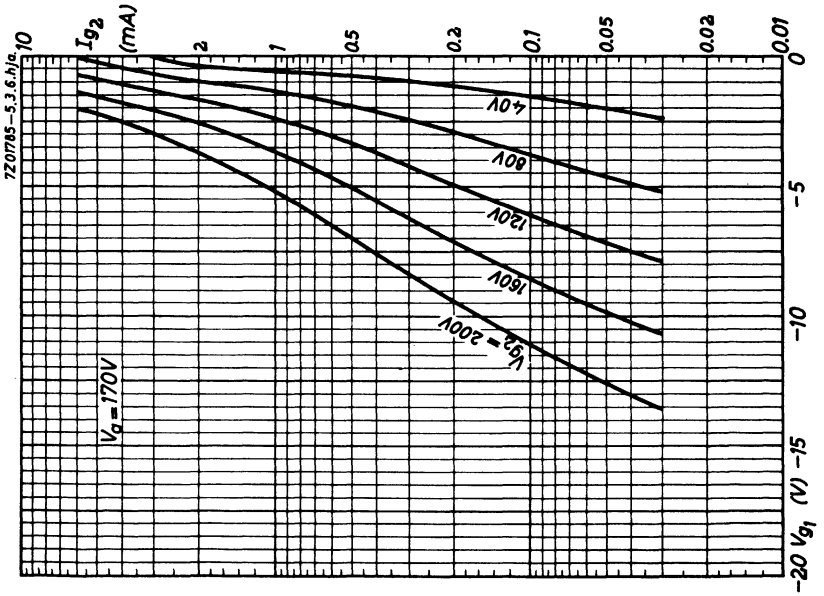
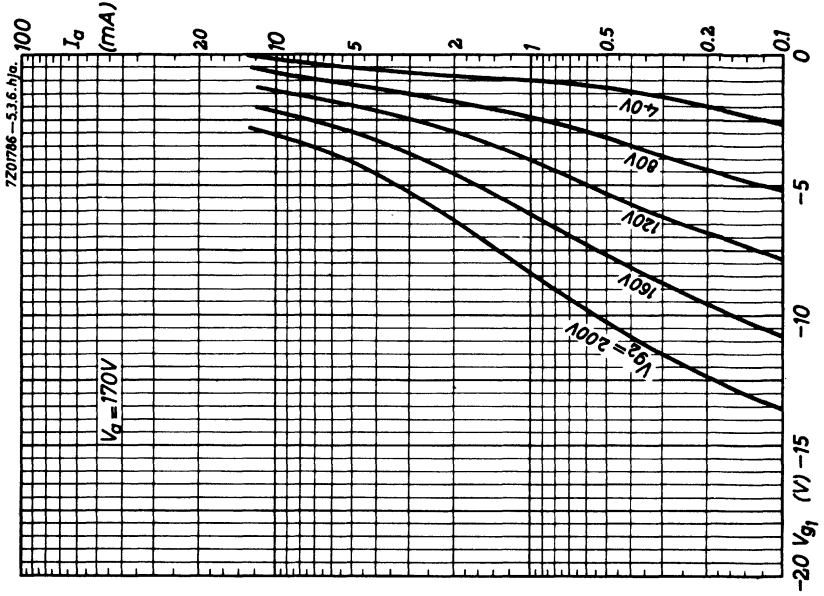



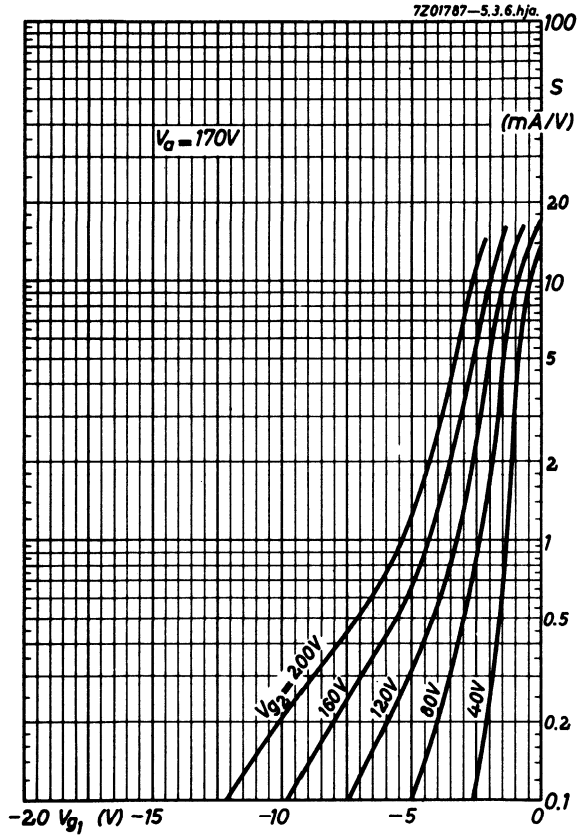

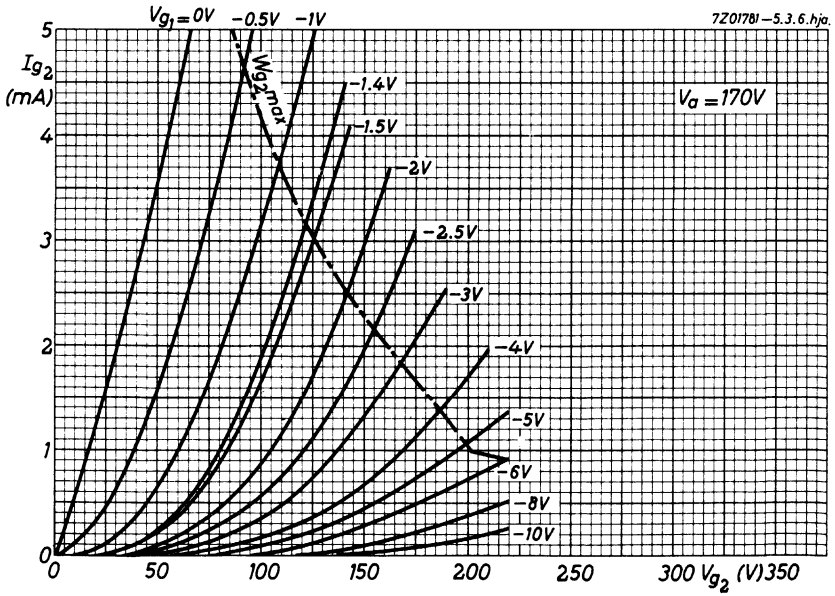
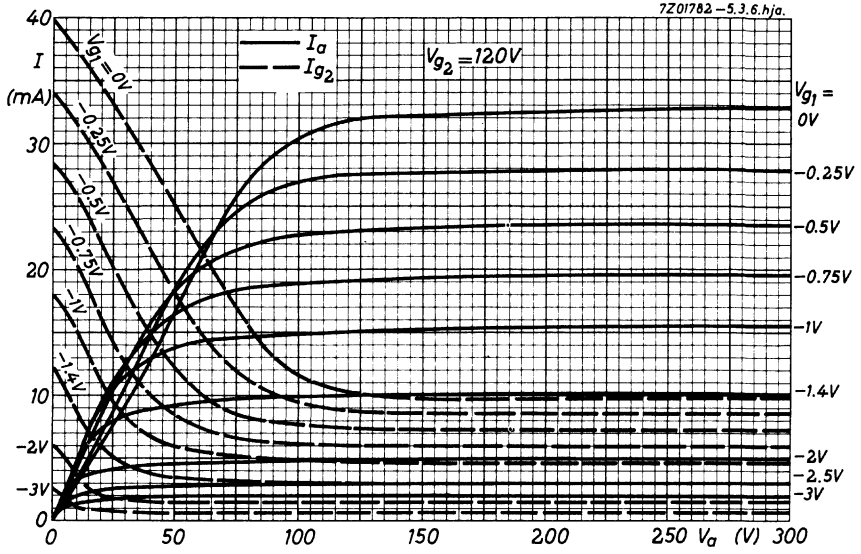

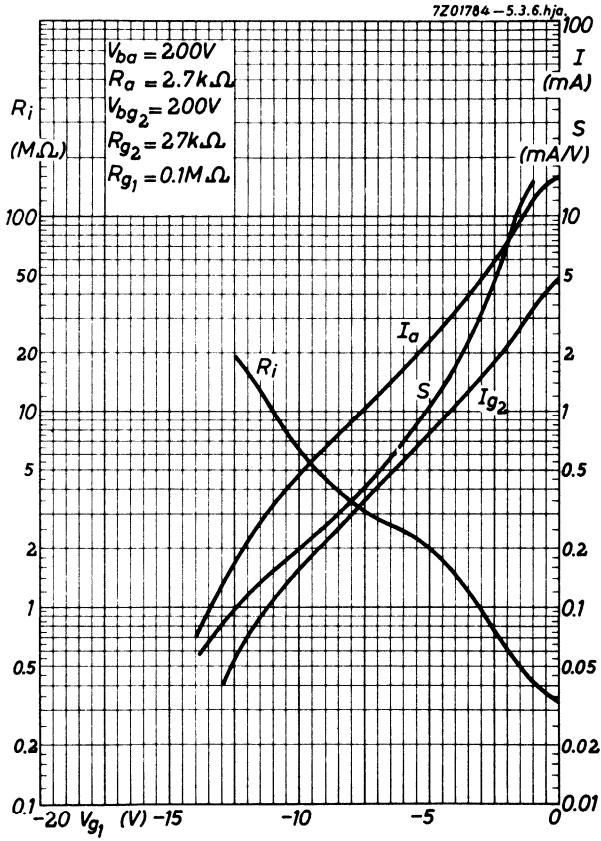

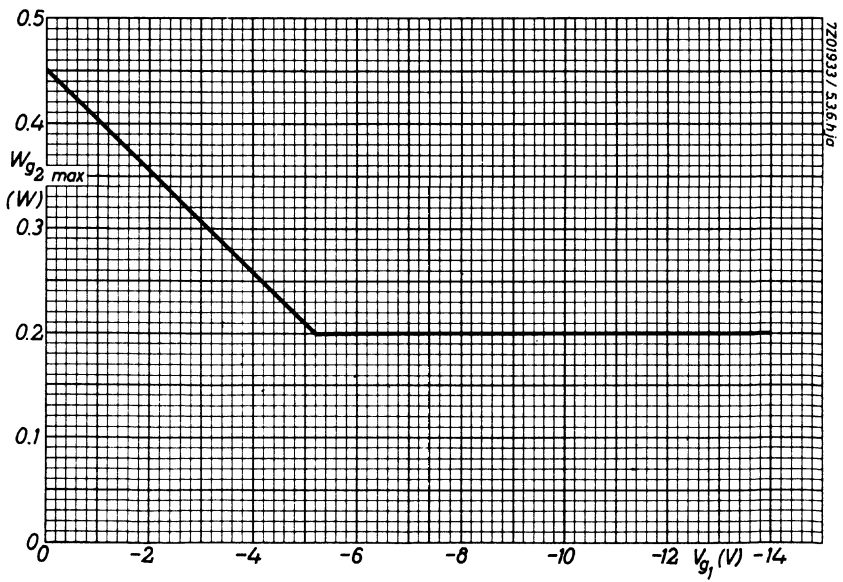
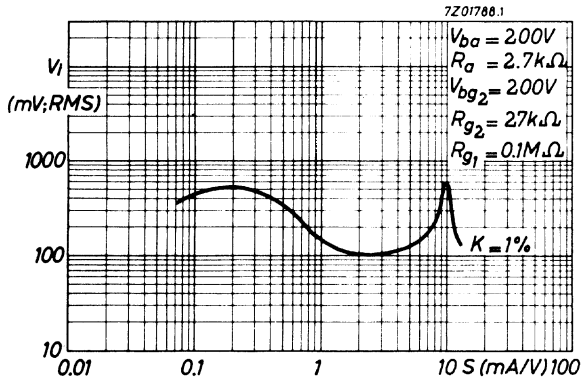

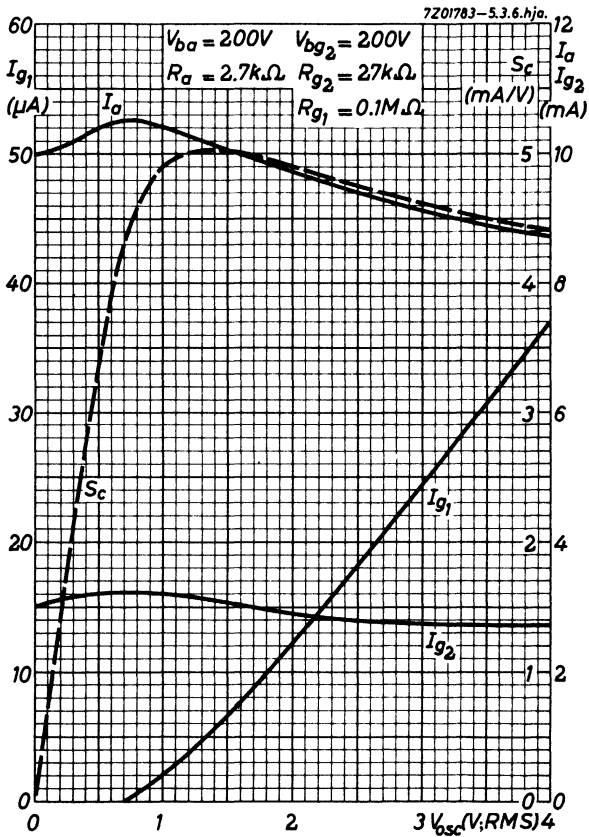

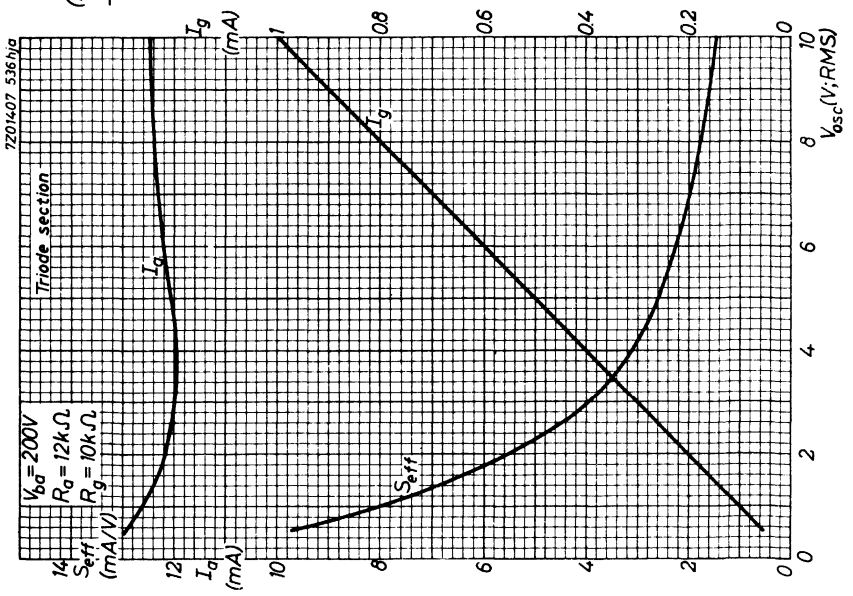
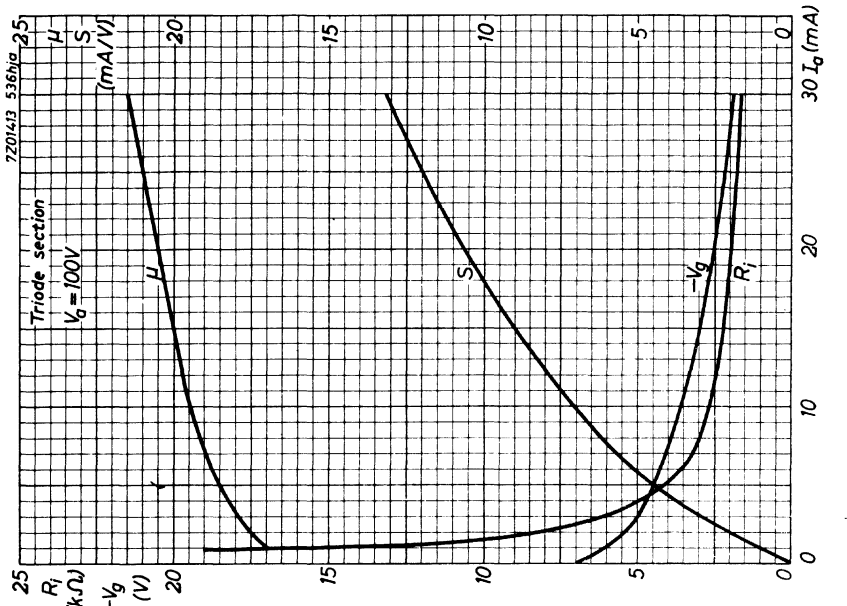

## TRIODE-PENTODE

Triode pentode; triode section intended for use as reactance tube, pentode section intended for use as sine wave oscillator or pulse shaper in television receivers.

### QUICK REFERENCE DATA

| <u>Pentode section</u> |                |                |
|------------------------|----------------|----------------|
| Anode current          | $I_a$          | 6 mA           |
| Transconductance       | $S$            | 5.5 mA/V       |
| Amplification factor   | $\mu_{g_2g_1}$ | 47 -           |
| Internal resistance    | $R_i$          | 400 k $\Omega$ |
| <u>Triode section</u>  |                |                |
| Anode current          | $I_a$          | 3.5 mA         |
| Transconductance       | $S$            | 3.5 mA/V       |
| Amplification factor   | $\mu$          | 70 -           |

**HEATING:** Indirect by A.C. or D.C.; series supply

|                |       |        |
|----------------|-------|--------|
| Heater current | $I_f$ | 300 mA |
| Heater voltage | $V_f$ | 9 V    |

### DIMENSIONS AND CONNECTIONS

Dimensions in mm

Base: Noval

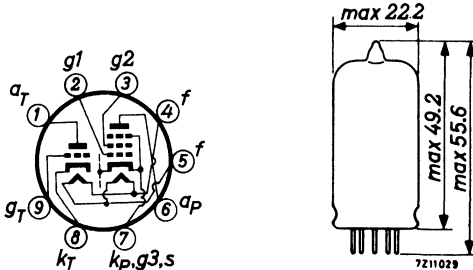

**CAPACITANCES**

Pentode section

|                               |             |             |
|-------------------------------|-------------|-------------|
| Grid No.1 to all except anode | $C_{g1(a)}$ | 5.4 pF      |
| Anode to grid No.1            | $C_{ag1}$   | 0.06 pF     |
| Grid No.1 to heater           | $C_{g1f}$   | max. 0.1 pF |

Triode section

|                          |            |             |
|--------------------------|------------|-------------|
| Grid to all except anode | $C_{g(a)}$ | 2.4 pF      |
| Anode to grid            | $C_{ag}$   | 1.5 pF      |
| Grid to heater           | $C_{gf}$   | max. 0.1 pF |

**TYPICAL CHARACTERISTICS**

Pentode section

|                      |              |     |      |          |           |            |
|----------------------|--------------|-----|------|----------|-----------|------------|
| Anode voltage        | $V_a$        | 100 | 100  | 200      | 100       | V          |
| Grid No.2 voltage    | $V_{g2}$     | 100 | 100  | 200      | 100       | V          |
| Grid No.1 voltage    | $V_{g1}$     | -1  | 0    | max. -16 | max. -1.3 | V          |
| Anode current        | $I_a$        | 6   | 12.5 | 0.01     | -         | mA         |
| Grid No.2 current    | $I_{g2}$     | 1.7 | 3.5  | -        | -         | mA         |
| Transconductance     | $S$          | 5.5 | -    | -        | -         | mA/V       |
| Internal resistance  | $R_i$        | 400 | -    | -        | -         | k $\Omega$ |
| Amplification factor | $\mu_{g2g1}$ | 47  | -    | -        | -         | -          |
| Grid No.1 current    | $I_{g1}$     | -   | -    | -        | 0.3       | $\mu A$    |

Triode section

|                      |       |     |     |           |            |
|----------------------|-------|-----|-----|-----------|------------|
| Anode voltage        | $V_a$ | 200 | 200 | 200       | V          |
| Grid voltage         | $V_g$ | -2  | -   | max. -1.3 | V          |
| Anode current        | $I_a$ | 3.5 | 10  | -         | mA         |
| Transconductance     | $S$   | 3.5 | -   | -         | mA/V       |
| Internal resistance  | $R_i$ | 20  | -   | -         | k $\Omega$ |
| Amplification factor | $\mu$ | 70  | -   | -         | -          |
| Grid current         | $I_g$ | -   | 10  | 0.3       | $\mu A$    |



**LIMITING VALUES** (Design centre rating system)

Pentode section

|  |                      |      |                              |
|--|----------------------|------|------------------------------|
| Anode voltage                                  | $V_{aO}$             | max. | 550 V                        |
|  | $V_a$                | max. | 250 V                        |
| Anode dissipation                              | $W_a$                | max. | 1.2 W                        |
| Grid No.2 voltage                              | $V_{g2O}$            | max. | 550 V <sup>1)</sup>          |
|  | $V_{g2}$             | max. | 250 V                        |
| Grid No.2 dissipation                          | $W_{g2}$             | max. | 0.8 W                        |
| Grid No.1 voltage                              | $-V_{g1}$            | max. | 220 V <sup>1)</sup>          |
| Grid resistor, fixed bias                      | $R_{g1}$             | max. | 0.56 M $\Omega$              |
| automatic bias                                 | $R_{g1}$             | max. | 1 M $\Omega$                 |
| Cathode current, average                       | $I_k$                | max. | 15 mA                        |
| peak   | $I_{kp}$             | max. | 50 mA                        |
| $T_{imp} = \max. 30 \mu s, \delta = \max. 0.3$ |                      |      |                              |
| Cathode to heater voltage                      | $V_{kf}$             | max. | 100 V <sup>2)</sup>          |
| Grid circuit impedance                         | $Z_{g1}$ (f = 50 Hz) | max. | 300 k $\Omega$ <sup>2)</sup> |

Triode section

|                           |                   |      |                             |
|---------------------------|-------------------|------|-----------------------------|
| Anode voltage             | $V_{aO}$          | max. | 550 V                       |
|                           | $V_a$             | max. | 250 V                       |
| Anode dissipation         | $W_a$             | max. | 1.4 W                       |
| Grid resistor, fixed bias | $R_g$             | max. | 3 M $\Omega$                |
| Cathode current           | $I_k$             | max. | 10 mA                       |
| Cathode to heater voltage | $V_{kf}$          | max. | 100 V <sup>3)</sup>         |
| Grid circuit impedance    | $Z_g$ (f = 50 Hz) | max. | 50 k $\Omega$ <sup>3)</sup> |

<sup>1)</sup> The instantaneous voltage between grid No.1 and grid No.2 should never exceed 550 V.

<sup>2)</sup> To avoid hum interference the A.C. component of  $V_{kf}$  should not exceed 65 V at the specified value of  $Z_{g1}$ .

<sup>3)</sup> To minimise hum interference decoupling of  $R_k$  is recommended. In circuits with undecoupled  $R_k$  the hum interference between grid and cathode will remain below 1000  $\mu V$  when the A.C. component of  $V_{kf}$  does not exceed 25 V and the  $R_k$  is not higher than 1.2 k $\Omega$  at the specified value of  $Z_g$ .

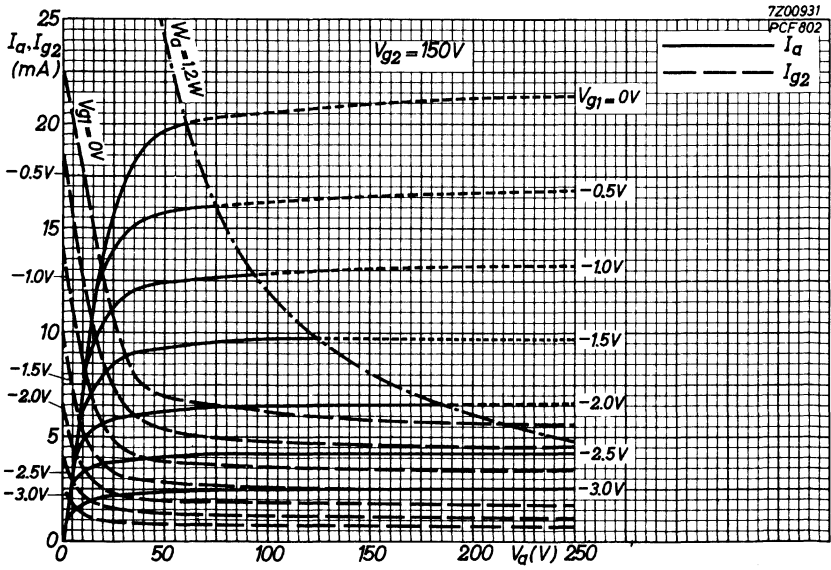
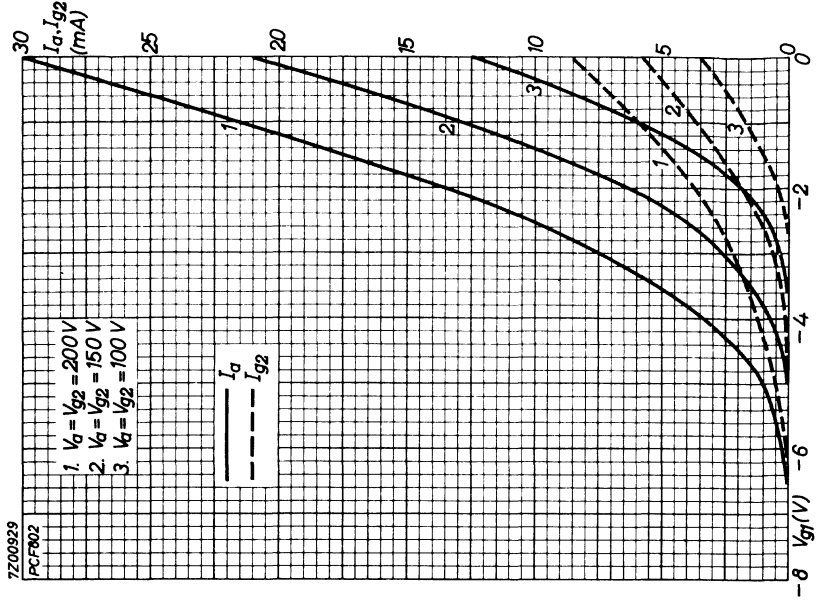

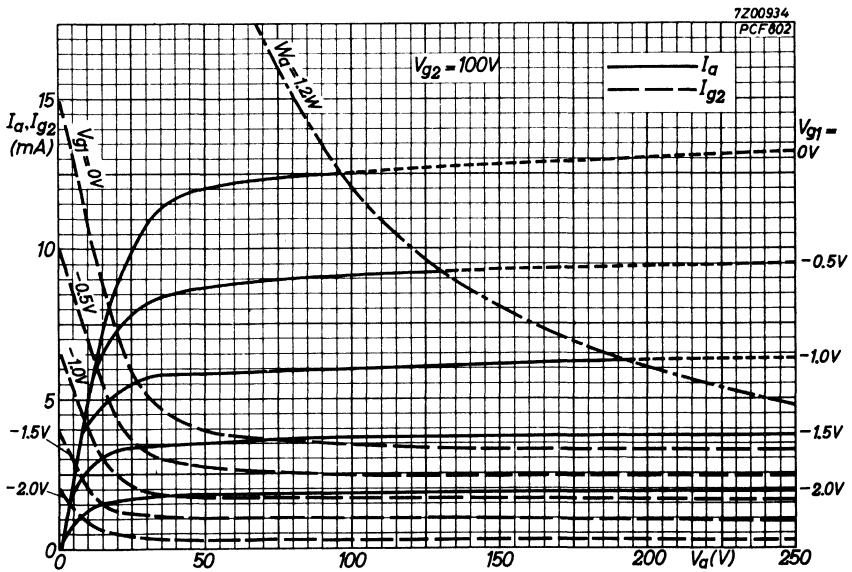
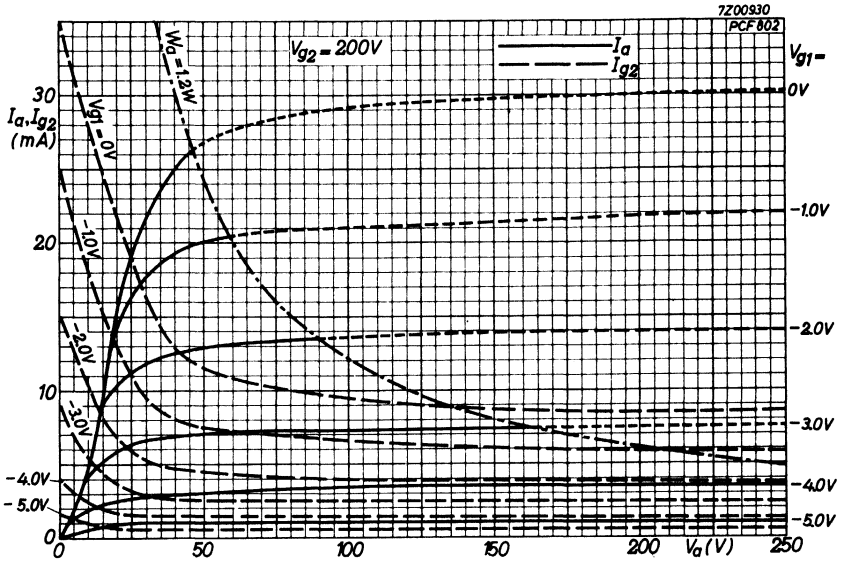

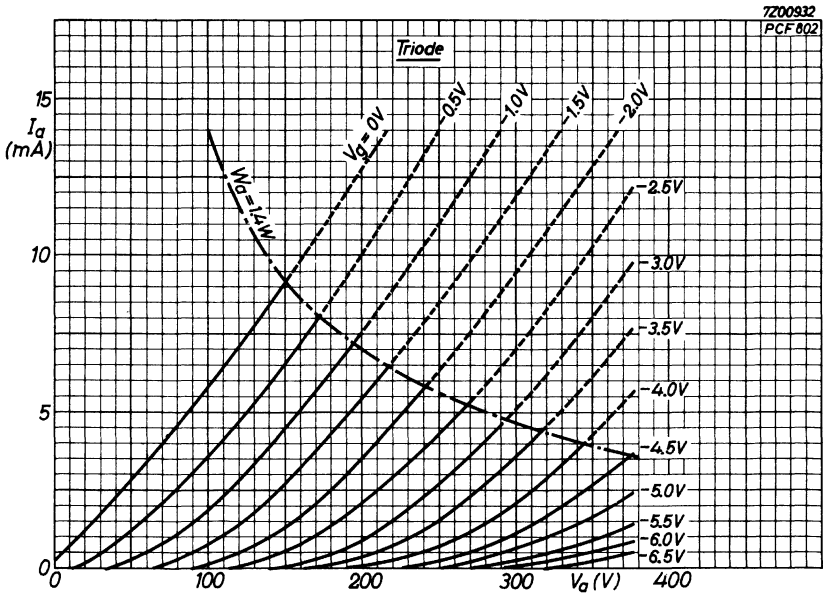
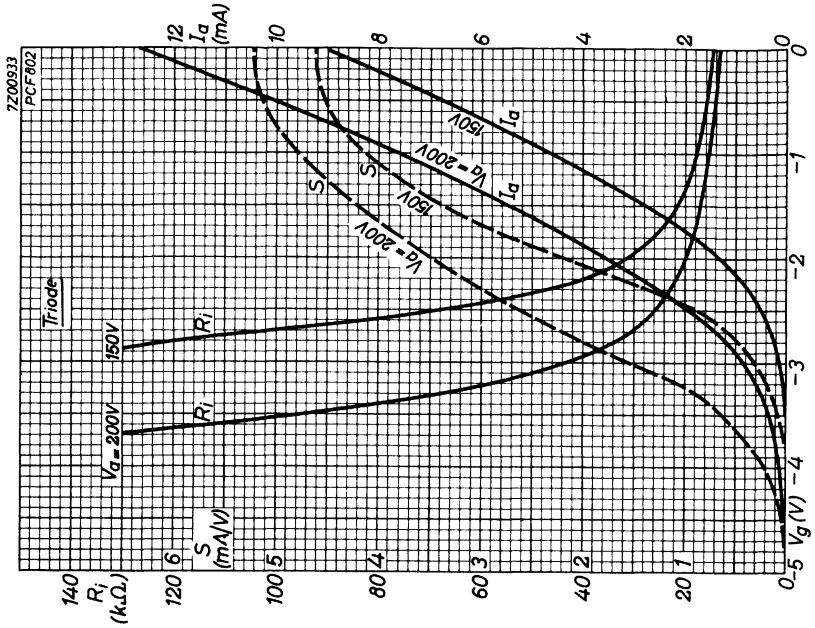

## TRIODE-HEPTODE

Triode-heptode; triode section intended for use as pulse amplifier and heptode section for use as noise gated sync. separator.

| QUICK REFERENCE DATA   |          |      |               |
|------------------------|----------|------|---------------|
| <u>Triode section</u>  |          |      |               |
| Anode current          | $I_a$    | 9    | mA            |
| Transconductance       | S        | 8.8  | mA/V          |
| Amplification factor   | $\mu$    | 50   | -             |
| <u>Heptode section</u> |          |      |               |
| Grid No.1 voltage      | $V_{g1}$ | 0    | -1.8 0 V      |
| Grid No.3 voltage      | $V_{g3}$ | 0    | 0 -1.8 V      |
| Anode current          | $I_a$    | 1500 | 20 20 $\mu$ A |

**HEATING:** Indirect by A.C. or D.C.; series supply

|                |       |     |    |
|----------------|-------|-----|----|
| Heater current | $I_f$ | 300 | mA |
| Heater voltage | $V_f$ | 8.5 | V  |

### DIMENSIONS AND CONNECTIONS

Dimensions in mm

Base: decal

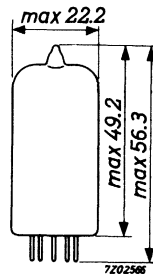
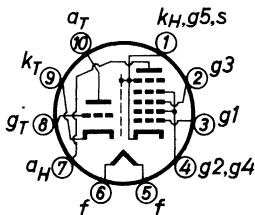

**CAPACITANCES**

Heptode section

|                               |              |              |
|-------------------------------|--------------|--------------|
| Grid No.1 to all except anode | $C_{g_1(a)}$ | 4.4 pF       |
| Anode to all except grid No.1 | $C_{a(g_1)}$ | 5.4 pF       |
| Anode to grid No.1            | $C_{ag_1}$   | max. 0.1 pF  |
| Anode to grid No.3            | $C_{ag_3}$   | max. 0.25 pF |
| Grid No.1 to grid No.3        | $C_{g_1g_3}$ | 0.3 pF       |

Triode section

|                          |          |        |
|--------------------------|----------|--------|
| Grid to all except anode | $C_g(a)$ | 3.3 pF |
| Anode to all except grid | $C_a(g)$ | 1.7 pF |
| Anode to grid            | $C_{ag}$ | 1.8 pF |

Between heptode and triode sections

|                                   |              |               |
|-----------------------------------|--------------|---------------|
| Heptode grid No.1 to triode grid  | $C_{g_1HgT}$ | max. 0.005 pF |
| Heptode grid No.1 to triode anode | $C_{g_1HaT}$ | max. 0.010 pF |
| Heptode grid No.3 to triode grid  | $C_{g_3HgT}$ | max. 0.020 pF |
| Heptode anode to triode anode     | $C_{aHaT}$   | max. 0.150 pF |

**TYPICAL CHARACTERISTICS**

Triode section

|                      |       |     |          |      |
|----------------------|-------|-----|----------|------|
| Anode voltage        | $V_a$ | 100 | 200      | V    |
| Anode current        | $I_a$ | 9.0 | 0.1      | mA   |
| Grid voltage         | $V_g$ | -1  | -7 (<11) | V    |
| Transconductance     | S     | 8.8 | -        | mA/V |
| Amplification factor | $\mu$ | 50  | -        | -    |

Heptode section

|                          |                |      |      |             |         |
|--------------------------|----------------|------|------|-------------|---------|
| Anode voltage            | $V_a$          | 14   | 14   | 14          | V       |
| Grids No.2 and 4 voltage | $V_{g_2, g_4}$ | 14   | 14   | 14          | V       |
| Grid No.3 voltage        | $V_{g_3}$      | 0    | 0    | -1.8 (<2.2) | V       |
| Grid No.1 voltage        | $V_{g_1}$      | 0    | -1.8 | 0           | V       |
| Anode current            | $I_a$          | 1500 | 20   | 20          | $\mu A$ |
| Grids No.2 and 4 current | $I_{g_2+g_4}$  | 1300 | -    | -           | $\mu A$ |

**OPERATING CHARACTERISTICS**

Heptode section as sync. separator

|                          |                |     |      |     |             |         |
|--------------------------|----------------|-----|------|-----|-------------|---------|
| Anode voltage            | $V_a$          | 14  | 1    | 14  | 14          | V       |
| Grids No.2 and 4 voltage | $V_{g_2, g_4}$ | 14  | 14   | 14  | 14          | V       |
| Grid No.3 voltage        | $V_{g_3}$      | -   | -    | +25 | -1.9 (<2.3) | V       |
| Grid No.1 voltage        | $V_{g_1}$      | -   | -    | -2  | -           | V       |
| Anode current            | $I_a$          | 750 | >300 | 20  | 20          | $\mu A$ |
| Grid No.3 current        | $I_{g_3}$      | 1   | 1    | -   | -           | $\mu A$ |
| Grid No.1 current        | $I_{g_1}$      | 100 | 100  | -   | 100         | $\mu A$ |

## LIMITING VALUES (Design centre rating system)

### Triode section

|                             |            |  |
|-----------------------------|------------|--|
| Anode voltage               | $V_{a0}$   | max. 550 V                                       |
|                             | $V_a$      | max. 250 V                                       |
| Anode dissipation           | $W_a$      | max. 1.5 W                                       |
| Cathode current             | $I_k$      | max. 20 mA                                       |
| Grid resistor (fixed bias)  | $R_g$      | max. 2 MΩ  |
| (automatic bias)            | $R_g$      | max. 3 MΩ  |
| Grid voltage, negative peak | $-V_{g_p}$ | max. 200 V                                       |
| Cathode to heater voltage   | $V_{kf}$   | max. 70 V <sup>1)</sup><br>+100 V <sub>RMS</sub> |

### Heptode section

|                                  |                    |                         |
|----------------------------------|--------------------|-------------------------|
| Anode voltage                    | $V_{a0}$           | max. 550 V              |
|                                  | $V_a$              | max. 100 V              |
| Grids No.2 and 4 voltage         | $V_{(g_2, g_4)_0}$ | max. 550 V              |
|                                  | $V_{g_2, g_4}$     | max. 50 V <sup>2)</sup> |
| Anode dissipation                | $W_a$              | max. 0.5 W              |
| Grids No.2 and 4 dissipation     | $W_{g_2+g_4}$      | max. 0.5 W              |
| Cathode current                  | $I_k$              | max. 8 mA               |
| Grid No.1 resistor               | $R_{g_1}$          | max. 3 MΩ               |
| Grid No.3 resistor               | $R_{g_3}$          | max. 3 MΩ               |
| Grid No.1 voltage, negative peak | $-V_{g_{1p}}$      | max. 100 V              |
| Grid No.3 voltage, negative peak | $-V_{g_{3p}}$      | max. 150 V              |
| Cathode to heater voltage        | $V_{kf}$           | max. 100 V              |

1) Cathode positive with respect to heater.

2) The grids No.2 and 4 voltage should not be less than 6 V with an average tube under the worst probable operating conditions.



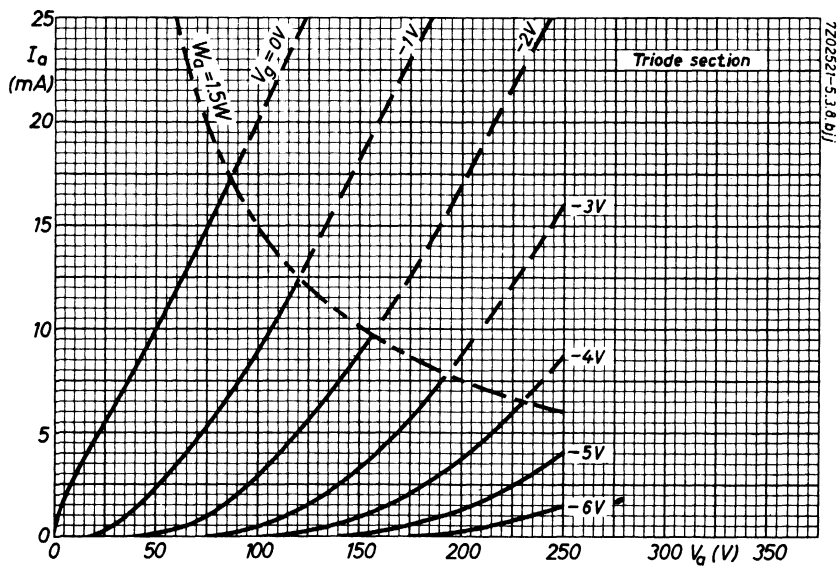
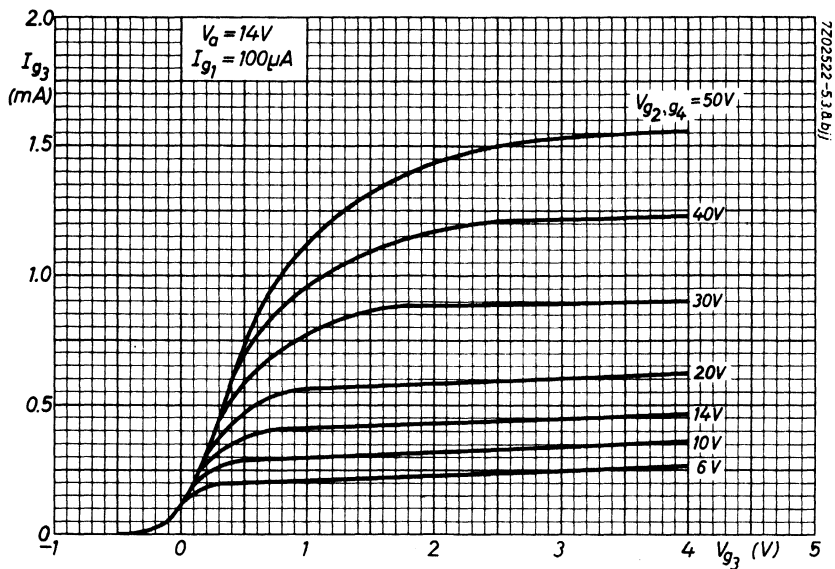

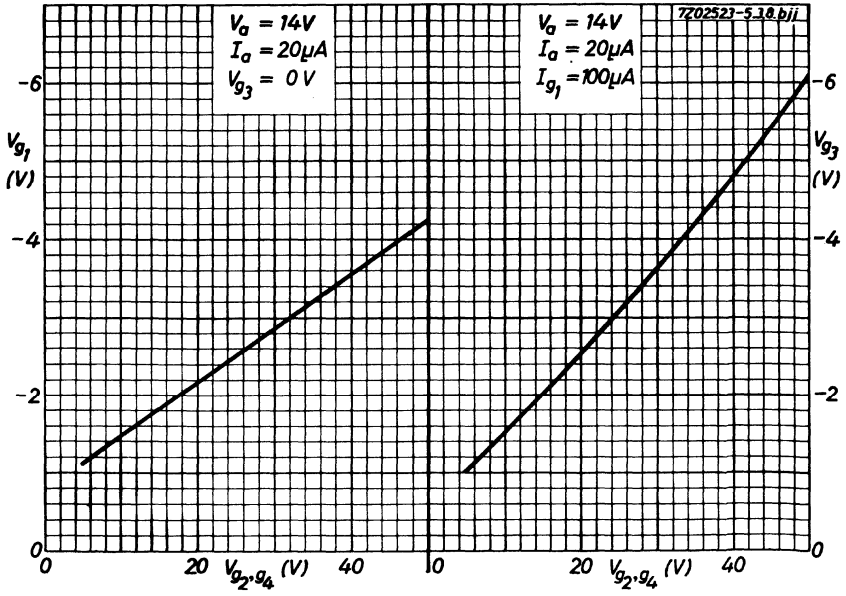
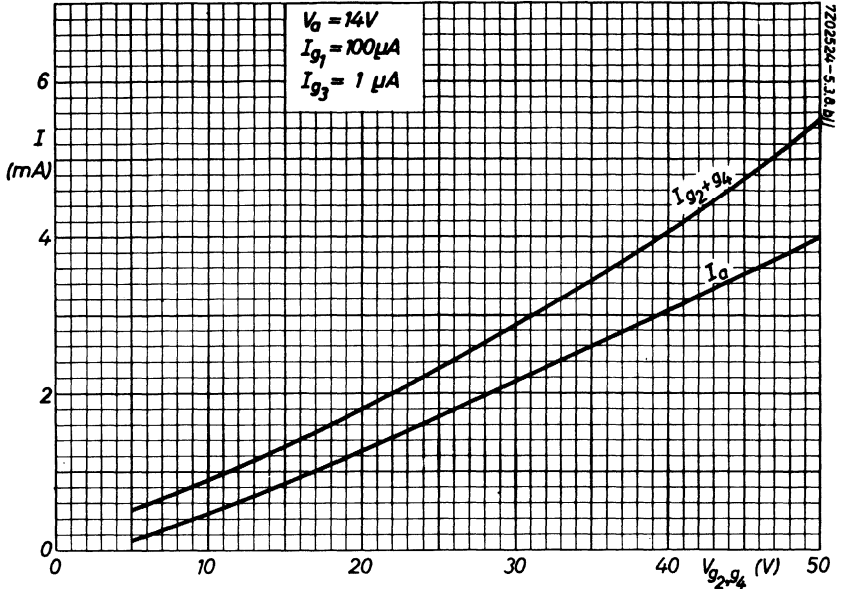

## TRIODE-OUTPUT PENTODE

The triode section is intended for use as frame oscillator and A.F. amplifier. The pentode section is intended for use as frame output tube and A.F. power amplifier.

| QUICK REFERENCE DATA   |                |          |      |
|------------------------|----------------|----------|------|
| <u>Triode section</u>  |                |          |      |
| Anode current          | $I_a$          | 3.5      | mA   |
| Transconductance       | $S$            | 2.2      | mA/V |
| Amplification factor   | $\mu$          | 70       | -    |
| <u>Pentode section</u> |                |          |      |
| Anode peak voltage     | $V_{a_p}$      | max. 2.5 | kV   |
| Anode current          | $I_a$          | 41       | mA   |
| Transconductance       | $S$            | 7.5      | mA/V |
| Amplification factor   | $\mu_{g_2g_1}$ | 9.5      | -    |
| Output power           | $W_o$          | 3.3      | W    |

**HEATING:** Indirect by A.C. or D.C.; series supply

|                |       |     |    |
|----------------|-------|-----|----|
| Heater current | $I_f$ | 300 | mA |
| Heater voltage | $V_f$ | 16  | V  |

### DIMENSIONS AND CONNECTIONS

Dimensions in mm

Base: Noval

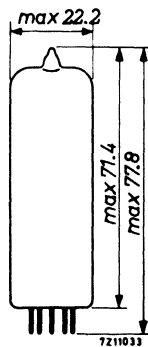
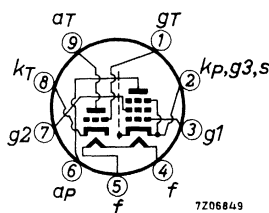

**CAPACITANCES**

Triode section

|                          |            |              |
|--------------------------|------------|--------------|
| Anode to all except grid | $C_{a(g)}$ | 4.3 pF       |
| Grid to all except anode | $C_{g(a)}$ | 2.7 pF       |
| Anode to grid            | $C_{ag}$   | 4.4 pF       |
| Grid to heater           | $C_{gf}$   | max. 0.02 pF |

Pentode section

|                               |              |             |
|-------------------------------|--------------|-------------|
| Anode to all except grid No.1 | $C_{a(g_1)}$ | 8.0 pF      |
| Grid No.1 to all except anode | $C_{g_1(a)}$ | 9.3 pF      |
| Anode to grid No.1            | $C_{ag_1}$   | max. 0.3 pF |
| Grid No.1 to heater           | $C_{g_1f}$   | max. 0.3 pF |

Between triode and pentode sections

|                                   |              |               |
|-----------------------------------|--------------|---------------|
| Anode triode to grid No.1 pentode | $C_{aTg_1P}$ | max. 0.02 pF  |
| Grid triode to anode pentode      | $C_{gTaP}$   | max. 0.02 pF  |
| Grid triode to grid No.1 pentode  | $C_{gTg_1P}$ | max. 0.025 pF |
| Anode triode to anode pentode     | $C_{aTaP}$   | max. 0.25 pF  |

**TYPICAL CHARACTERISTICS**

Triode section

|                      |       |          |
|----------------------|-------|----------|
| Anode voltage        | $V_a$ | 100 V    |
| Grid voltage         | $V_g$ | 0 V      |
| Anode current        | $I_a$ | 3.5 mA   |
| Transconductance     | $S$   | 2.2 mA/V |
| Amplification factor | $\mu$ | 70 -     |

Pentode section

|                      |                |               |
|----------------------|----------------|---------------|
| Anode voltage        | $V_a$          | 170 V         |
| Grid No.2 voltage    | $V_{g_2}$      | 170 V         |
| Grid No.1 voltage    | $V_{g_1}$      | -11.5 V       |
| Anode current        | $I_a$          | 41 mA         |
| Grid No.2 current    | $I_{g_2}$      | 9 mA          |
| Transconductance     | $S$            | 7.5 mA/V      |
| Amplification factor | $\mu_{g_2g_1}$ | 9.5 -         |
| Internal resistance  | $R_i$          | 16 k $\Omega$ |

**OPERATING CHARACTERISTICS**

Triode section as A.F. amplifier

|                             |                         |      |      |           |      |           |
|-----------------------------|-------------------------|------|------|-----------|------|-----------|
| A. Signal source resistance | $R_s$                   | 0.22 |      | $M\Omega$ |      |           |
| Grid resistor               | $R_g$                   | 3    |      | $M\Omega$ |      |           |
| Grid resistor of next stage | $R_{g'}$                | 0.68 |      | $M\Omega$ |      |           |
| Supply voltage              | $V_b$                   | 200  | 170  | V         |      |           |
| Cathode resistor            | $R_k$                   | 2.2  | 2.7  | $k\Omega$ |      |           |
| Anode resistor              | $R_a$                   | 220  | 220  | $k\Omega$ |      |           |
| Anode current               | $I_a$                   | 0.52 | 0.43 | mA        |      |           |
| Voltage gain                | $V_o/V_i$ <sup>1)</sup> | 52   | 51   | -         |      |           |
| Max. output voltage         | $V_o$ max               | 26   | 25   | $V_{RMS}$ |      |           |
| Distortion                  | $d_{tot}$ <sup>2)</sup> | 1.6  | 2.3  | %         |      |           |
| <hr/>                       |                         |      |      |           |      |           |
| B. Signal source resistance | $R_s$                   | 0.22 |      | $M\Omega$ |      |           |
| Grid resistor               | $R_g$                   | 22   |      | $M\Omega$ |      |           |
| Grid resistor of next stage | $R_{g'}$                | 0.68 |      | $M\Omega$ |      |           |
| Supply voltage              | $V_b$                   | 200  | 200  | 170       | 170  | V         |
| Cathode resistor            | $R_k$                   | 0    | 0    | 0         | 0    | $\Omega$  |
| Anode resistor              | $R_a$                   | 100  | 220  | 100       | 220  | $k\Omega$ |
| Anode current               | $I_a$                   | 1.05 | 0.61 | 0.86      | 0.50 | mA        |
| Voltage gain                | $V_o/V_i$ <sup>1)</sup> | 50   | 55   | 49        | 53   | -         |
| Max. output voltage         | $V_o$ max               | 24   | 25   | 19        | 20   | $V_{RMS}$ |
| Distortion                  | $d_{tot}$ <sup>3)</sup> | 1.5  | 1.4  | 1.4       | 1.4  | %         |

**MICROPHONY AND HUM**

The triode section can be used without special precautions against microphony and hum in circuits in which an input voltage  $V_i \geq 10 \text{ mV}_{RMS}$  gives an output of 50 mW of the output stage.  $Z_g$  (50 Hz) =  $0.25 \text{ M}\Omega$ . The A.C. voltage between pin 4 and cathode should not exceed 6.3 V. If the tube is used in television circuits where the frequency of the heater supply is not synchronized with the frame frequency, this may cause interference due to hum. At page 8 the relation is shown between the permissible value of  $Z_{g1}$  of the pentode section and the A.C. voltage between pin 4 and the cathode. This curve applies to  $C_{g1f}$  is  $0.8 \text{ pF}$  (inclusive of wiring and tube socket).

1) Measured at small input voltage

2) At lower output voltages the distortion is proportionally lower.

3) At lower output voltages down to  $5 \text{ V}_{RMS}$  the distortion remains approximately constant. At values below  $5 \text{ V}_{RMS}$  the distortion is approximately proportional to  $V_o$ .

**OPERATING CHARACTERISTICS**

Pentode section

A.F. power amplifier, class A (measured with  $V_k$  constant)

|   |             |            |      |            |            |                      |      |     |      |      |    |
|---|-------------|------------|------|------------|------------|----------------------|------|-----|------|------|----|
| Supply voltage $V_{ba}=V_{bg_2}$          |             | 170        | 200  | 230        | V          |                      |      |     |      |      |    |
| Grid No.2 series resistor (non-decoupled) | $R_{g_2}$   | 0          | 470  | 1200       | $\Omega$   |                      |      |     |      |      |    |
| Cathode resistor                          | $R_k$       | 200        | 330  | 490        | $\Omega$   |                      |      |     |      |      |    |
| Load resistance                           | $R_{a\sim}$ | 3.25       | 4.5  | 6          | k $\Omega$ |                      |      |     |      |      |    |
| Grid No.1 driving voltage                 | $V_i$       | 0 0.61 5.9 |      | 0 0.66 6.7 |            | 0 0.75 7.8 $V_{RMS}$ |      |     |      |      |    |
| Anode current                             | $I_a$       | 42         | -    | 44         | 35         | -                    | 37   | 30  | -    | 31   | mA |
| Grid No.2 current                         | $I_{g_2}$   | 9.2        | -    | 15.5       | 7.8        | -                    | 13.3 | 6.6 | -    | 11.0 | mA |
| Output power                              | $W_o$       | 0          | 0.05 | 3.2        | 0          | 0.05                 | 3.3  | 0   | 0.05 | 3.25 | W  |
| Distortion                                | $d_{tot}$   | -          | -    | 10         | -          | -                    | 10   | -   | -    | 10   | %  |

A.F. power amplifier, class AB, two tubes in push-pull

|                           |              |      |        |            |                |    |
|---------------------------|--------------|------|--------|------------|----------------|----|
| Anode supply voltage      | $V_{ba}$     | 200  | 230    | V          |                |    |
| Grid No.2 supply voltage  | $V_{bg_2}$   | 200  | 200    | V          |                |    |
| Common cathode resistor   | $R_k$        | 170  | 200    | $\Omega$   |                |    |
| Load resistance           | $R_{aa\sim}$ | 4.5  | 7      | k $\Omega$ |                |    |
| Grid No.1 driving voltage | $V_i$        | 0    | 14.2   | 0          | 13.0 $V_{RMS}$ |    |
| Anode current             | $I_a$        | 2x35 | 2x42.5 | 2x30       | 2x34.5         | mA |
| Grid No.2 current         | $I_{g_2}$    | 2x8  | 2x16.5 | 2x6.2      | 2x13.5         | mA |
| Output power              | $W_o$        | 0    | 9.3    | 0          | 10             | W  |
| Distortion                | $d_{tot}$    | -    | 6.3    | -          | 5.5            | %  |

Frame output application

The circuit should operate satisfactorily with peak anode current  $I_{ap} = 85$  mA at  $V_a = 50$  V,  $V_{g_2} = 170$  V,  $I_f = 300$  mA. The minimum available  $I_{ap}$  value at end of life is

- 70 mA at  $V_a = 50$  V,  $V_{g_2} = 170$  V,  $I_f = 280$  mA
- 80 mA at  $V_a = 50$  V,  $V_{g_2} = 190$  V,  $I_f = 280$  mA



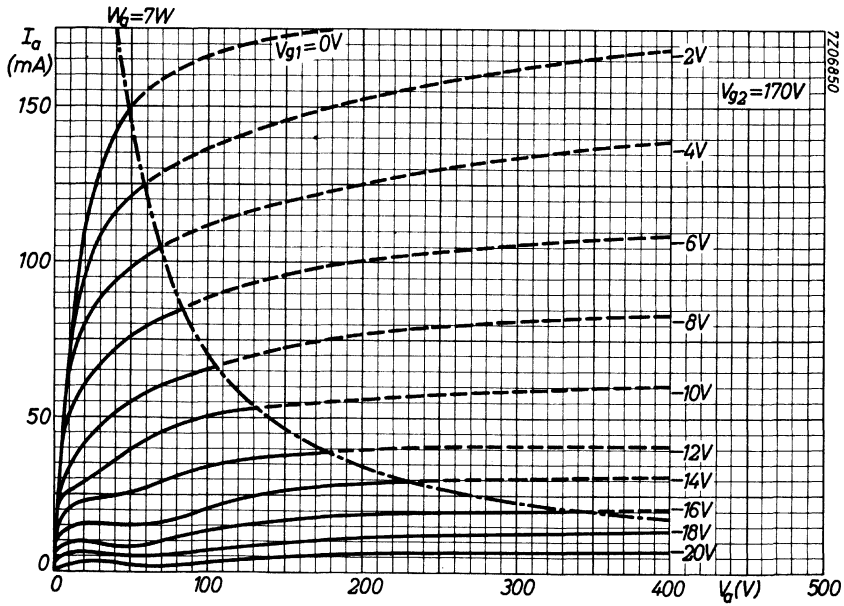
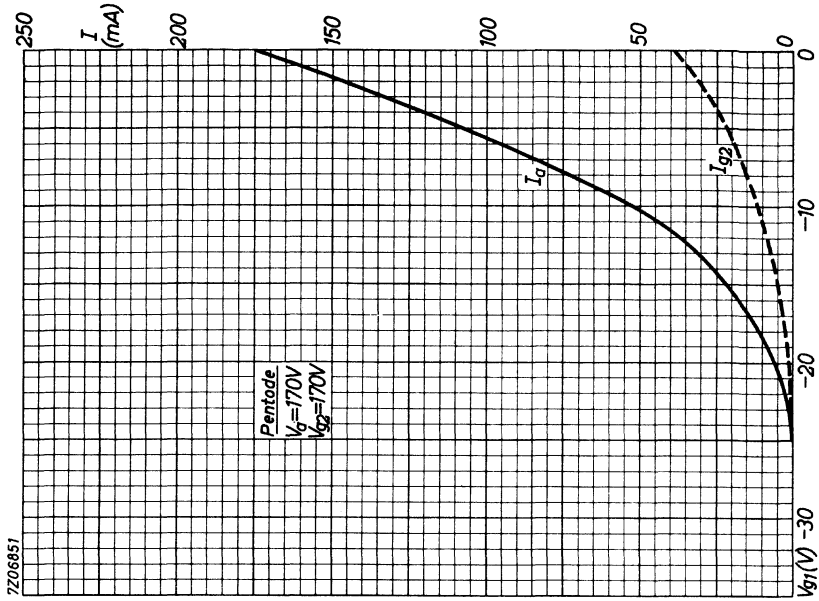



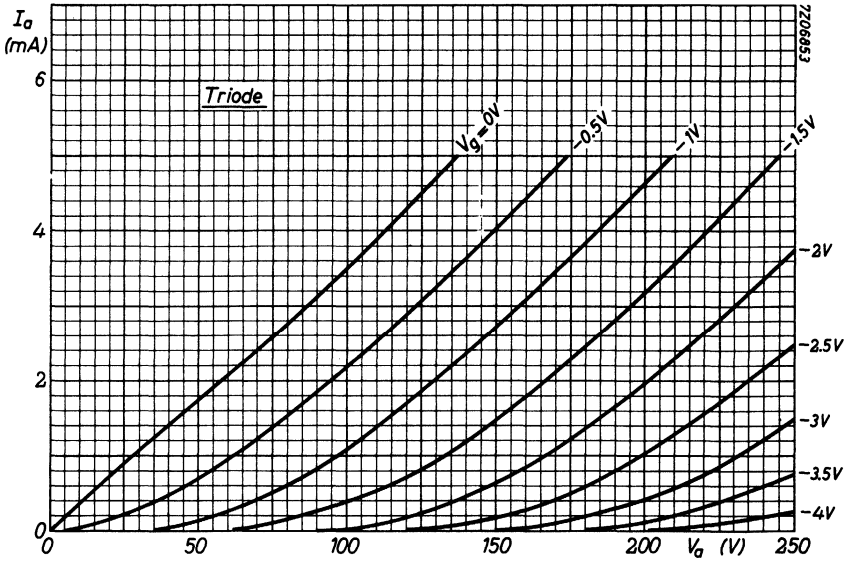
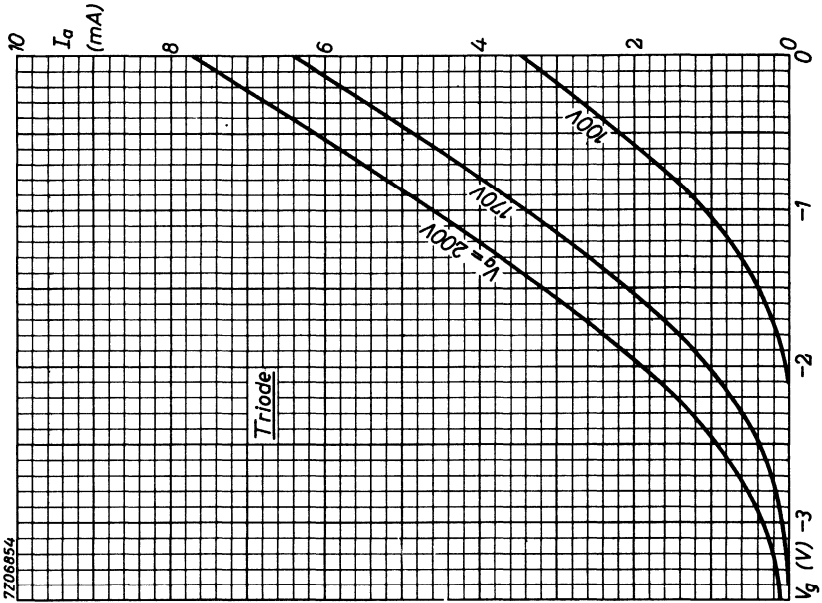

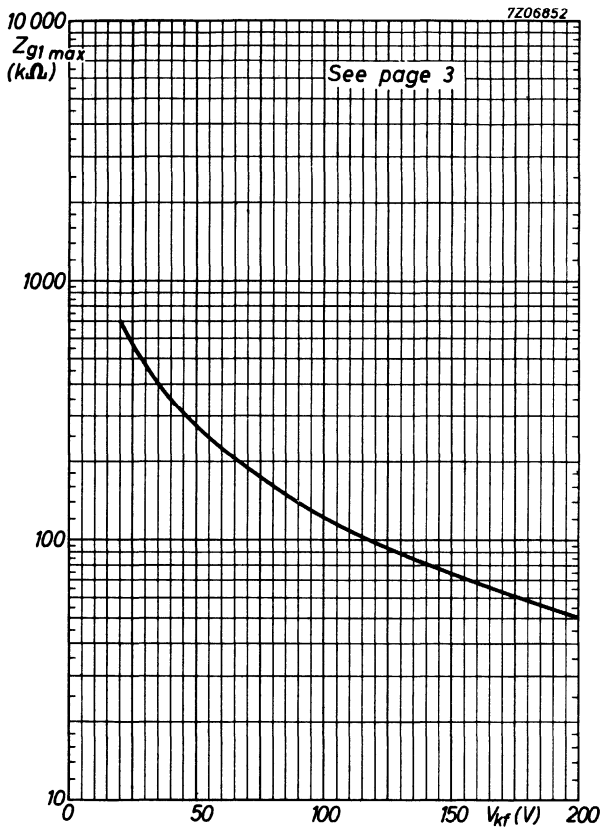

## TRIODE-OUTPUT PENTODE

Triode-pentode with separate cathodes.

Triode section intended for use in circuits for keyed A.G.C., sync. separation, sync. amplification and noise suppression.

Pentode section is intended for use as video output tube.

| QUICK REFERENCE DATA   |                |    |      |
|------------------------|----------------|----|------|
| <u>Triode section</u>  |                |    |      |
| Anode current          | $I_a$          | 3  | mA   |
| Transconductance       | S              | 4  | mA/V |
| Amplification factor   | $\mu$          | 65 | -    |
| <u>Pentode section</u> |                |    |      |
| Anode current          | $I_a$          | 18 | mA   |
| Transconductance       | S              | 11 | mA/V |
| Amplification factor   | $\mu_{g_2g_1}$ | 36 | -    |

**HEATING:** Indirect by A.C. or D.C.; series supply

Heater current

$I_f$  300 mA

Heater voltage

$V_f$  15 V

### DIMENSIONS AND CONNECTIONS

Dimensions in mm

Base: Noval

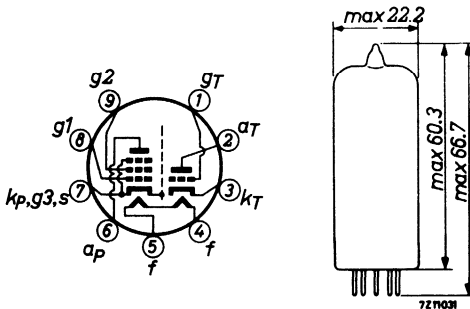

**CAPACITANCES**

Triode section

|                          |            |             |
|--------------------------|------------|-------------|
| Anode to all except grid | $C_{a(g)}$ | 2.3 pF      |
| Grid to all except anode | $C_{g(a)}$ | 3.8 pF      |
| Anode to grid            | $C_{ag}$   | 2.7 pF      |
| Grid to heater           | $C_{gf}$   | max. 0.1 pF |

Pentode section

|                                |              |             |
|--------------------------------|--------------|-------------|
| Anode to all except grid No. 1 | $C_{a(g_1)}$ | 4.2 pF      |
| Grid No. 1 to all except anode | $C_{g_1(a)}$ | 8.7 pF      |
| Anode to grid No. 1            | $C_{ag_1}$   | max. 0.1 pF |
| Grid No. 1 to heater           | $C_{g_1f}$   | max. 0.1 pF |

Between triode and pentode sections

|                                    |             |              |
|------------------------------------|-------------|--------------|
| Anode triode to grid No. 1 pentode | $C_{aTG1P}$ | max. 0.01 pF |
| Grid triode to grid No. 1 pentode  | $C_{gTG1P}$ | max. 0.01 pF |

**TYPICAL CHARACTERISTICS**

Triode section

|                      |       |        |
|----------------------|-------|--------|
| Anode voltage        | $V_a$ | 200 V  |
| Grid voltage         | $V_g$ | -1.7 V |
| Anode current        | $I_a$ | 3 mA   |
| Transconductance     | S     | 4 mA/V |
| Amplification factor | $\mu$ | 65 -   |

Pentode section

|                      |                |      |      |      |            |
|----------------------|----------------|------|------|------|------------|
| Anode voltage        | $V_a$          | 170  | 200  | 220  | $V_{\sim}$ |
| Grid No. 2 voltage   | $V_{g_2}$      | 170  | 200  | 220  | V          |
| Grid No. 1 voltage   | $V_{g_1}$      | -2.1 | -2.9 | -3.4 | V          |
| Anode current        | $I_a$          | 18   | 18   | 18   | mA         |
| Grid No. 2 current   | $I_{g_2}$      | 3.0  | 3.0  | 3.0  | mA         |
| Transconductance     | S              | 11   | 10.4 | 10   | mA/V       |
| Amplification factor | $\mu_{g_2g_1}$ | 36   | 36   | 36   | -          |
| Internal resistance  | $R_{i \min}$   | 100  | 130  | 150  | k $\Omega$ |



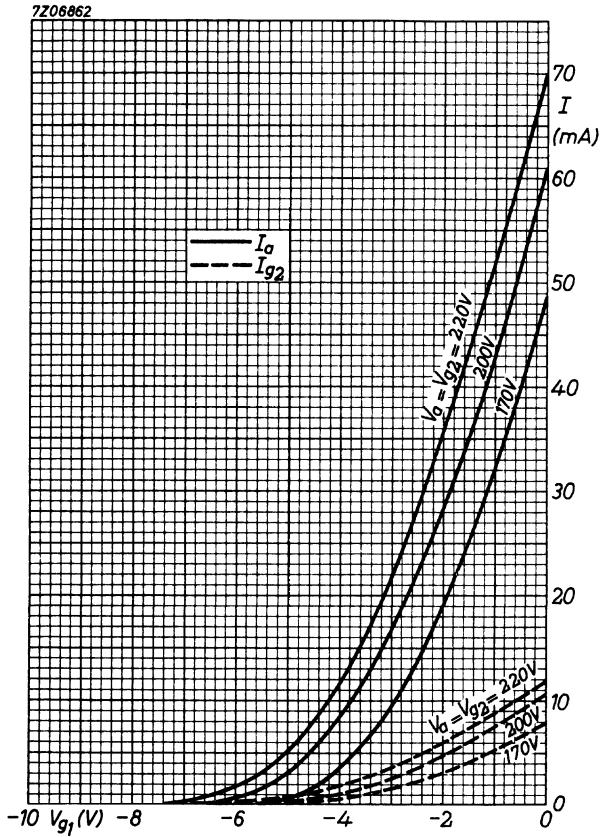

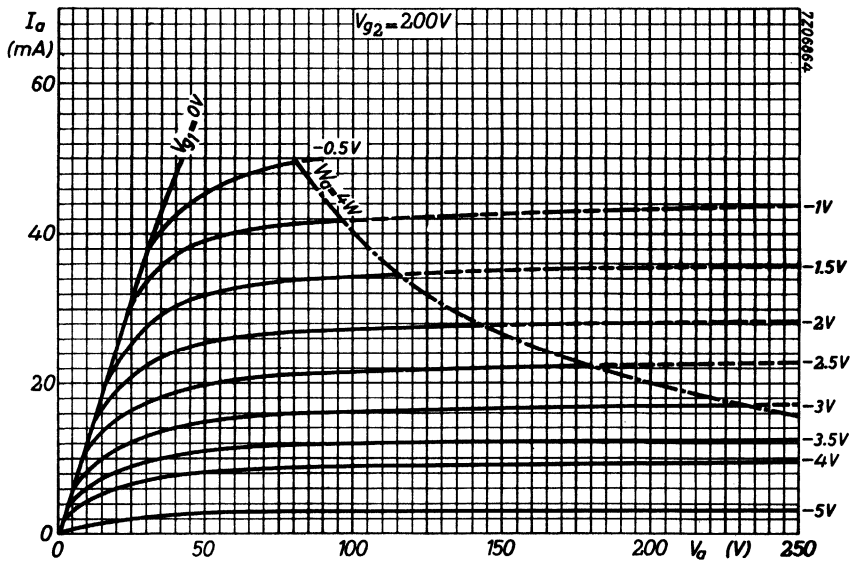
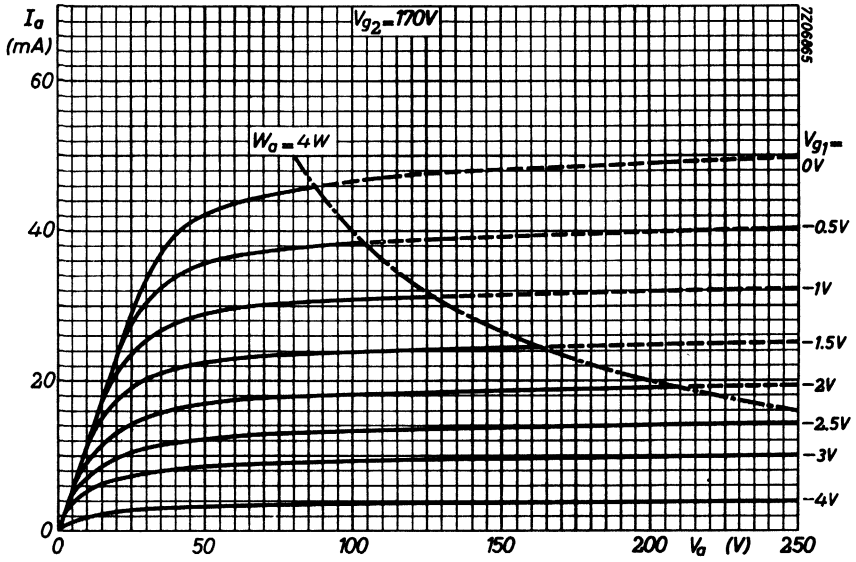

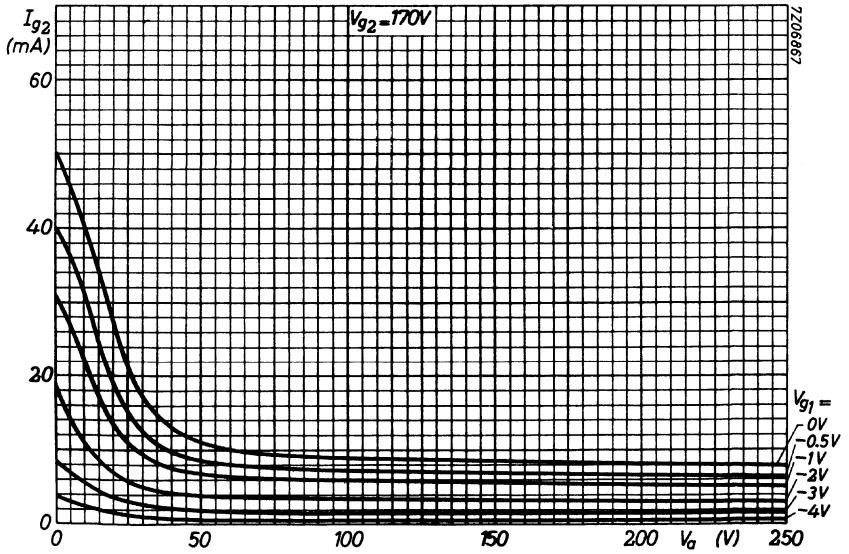
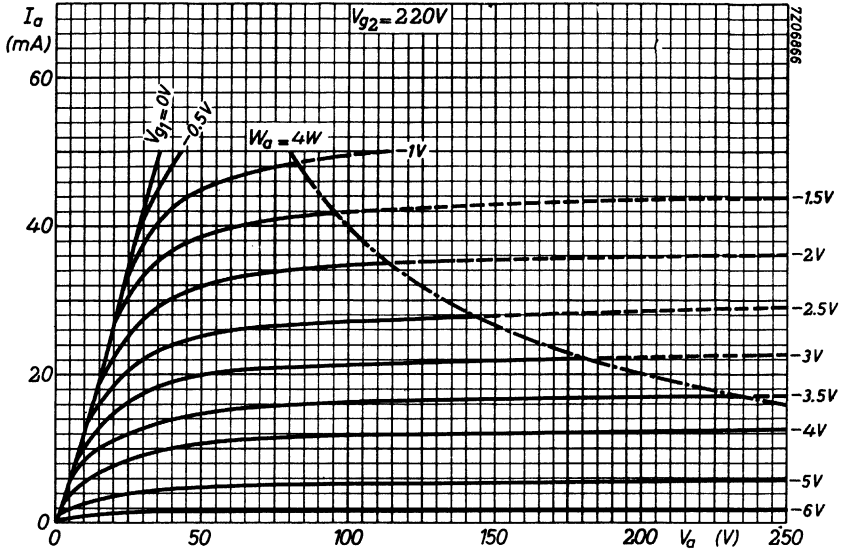



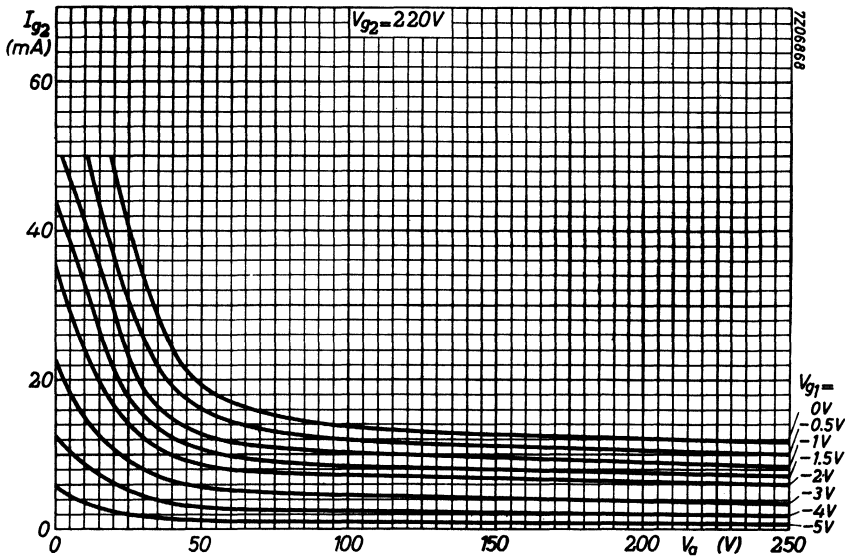
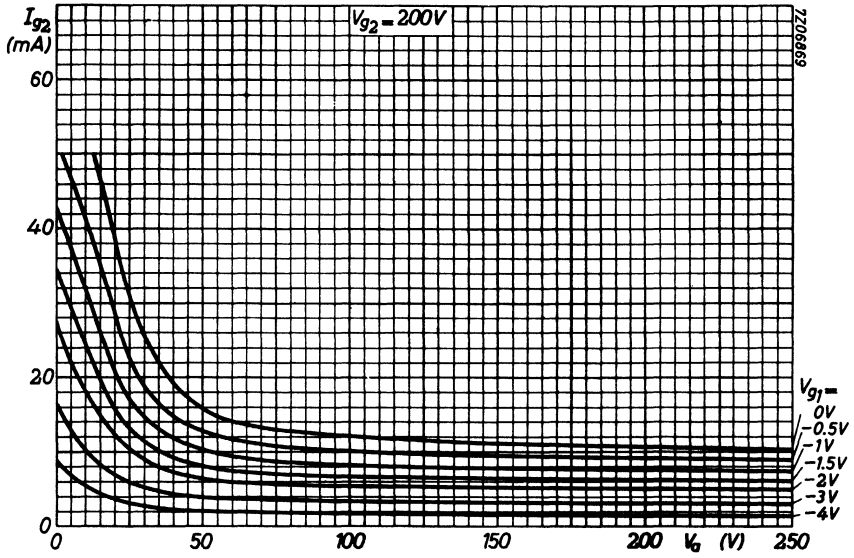

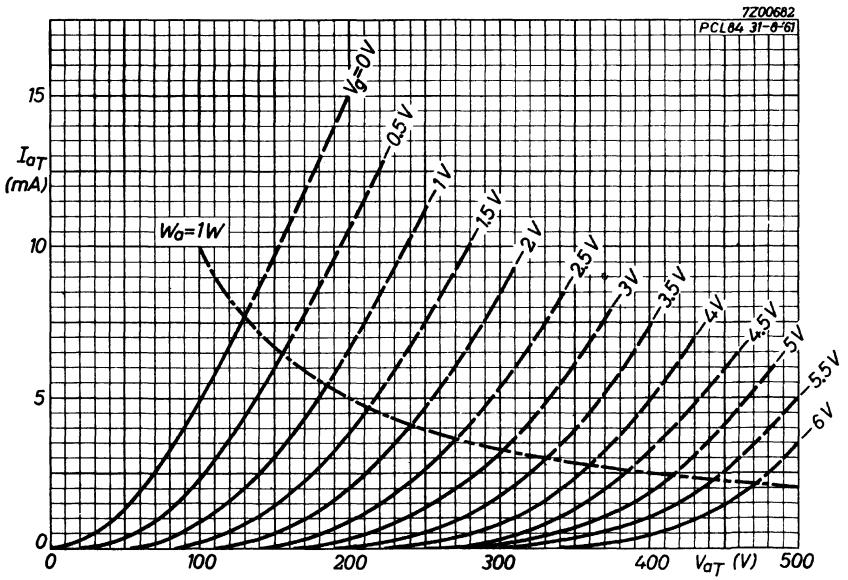
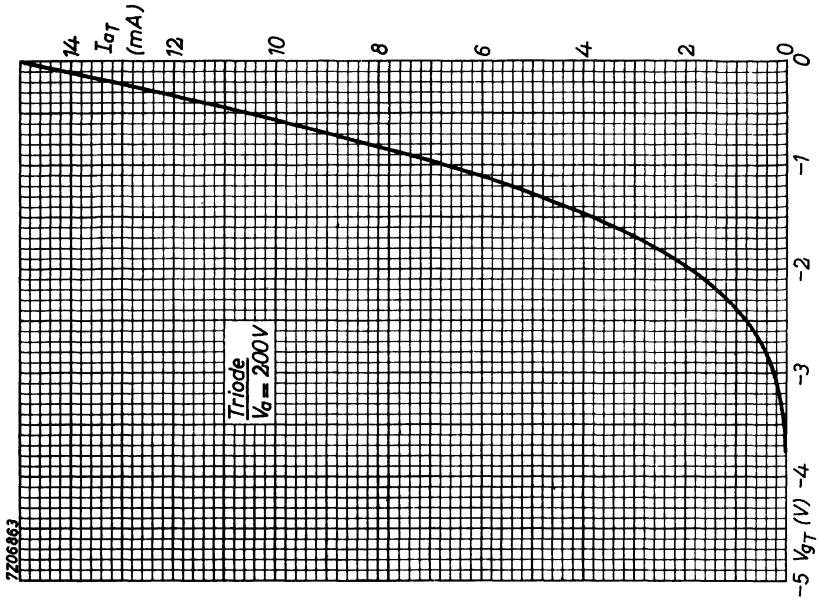

## TRIODE-FRAME OUTPUT PENTODE

Triode-pentode with separate cathodes. Triode intended for use as frame oscillator or pulse amplifier.

Pentode intended for use as frame output tube.

| QUICK REFERENCE DATA   |          |          |      |
|------------------------|----------|----------|------|
| <u>Triode section</u>  |          |          |      |
| Anode current          | $I_a$    | 10.5     | mA   |
| Transconductance       | $S$      | 7        | mA/V |
| Amplification factor   | $\mu$    | 63       | -    |
| Cathode peak current   | $I_{kp}$ | max. 150 | mA   |
| <u>Pentode section</u> |          |          |      |
| Anode peak voltage     | $V_{ap}$ | max. 2   | kV   |
| Cathode current        | $I_k$    | max. 75  | mA   |
| Anode dissipation      | $W_a$    | max. 8   | W    |

**HEATING:** Indirect by A.C. or D.C.; series supply

Heater current

$I_f$  300 mA

Heater voltage

$V_f$  17.5 V

### DIMENSIONS AND CONNECTIONS

Base: Noval

Dimensions in mm

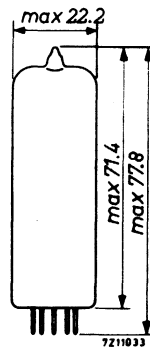
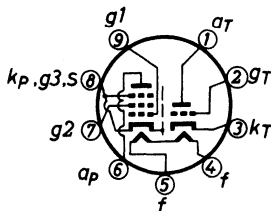

**CAPACITANCES**

|                                    |             |           |    |
|------------------------------------|-------------|-----------|----|
| Grid triode to anode pentode       | $C_{gTap}$  | max. 0.05 | pF |
| Grid triode to heater              | $C_{gTf}$   | max. 0.15 | pF |
| Grid No.1 pentode to anode pentode | $C_{g1pap}$ | max. 1.0  | pF |
| Grid No.1 pentode to anode triode  | $C_{g1paT}$ | max. 0.08 | pF |
| Grid No.1 pentode to heater        | $C_{g1pf}$  | max. 0.20 | pF |

**TYPICAL CHARACTERISTICS**

Triode section

|                      |       |       |      |            |
|----------------------|-------|-------|------|------------|
| Anode voltage        | $V_a$ | 100   | 100  | V          |
| Grid voltage         | $V_g$ | -0.85 | 0    | V          |
| Anode current        | $I_a$ | 5     | 10.5 | mA         |
| Transconductance     | $S$   | 5.5   | 7.0  | mA/V       |
| Amplification factor | $\mu$ | 60    | 63   | -          |
| Internal resistance  | $R_i$ | 11    | 9    | k $\Omega$ |

**OPERATING CHARACTERISTICS**

Pentode section

Frame output application

|                        |           |     |     |    |
|------------------------|-----------|-----|-----|----|
| Anode voltage          | $V_a$     | 50  | 65  | V  |
| Grid No.2 voltage      | $V_{g2}$  | 170 | 210 | V  |
| Grid No.1 voltage      | $V_{g1}$  | -1  | -1  | V  |
| Anode peak current     | $I_{ap}$  | 200 | 285 | mA |
| Grid No.2 peak current | $I_{g2p}$ | 35  | 45  | mA |

Remarks

The minimum  $I_{ap}$  value to be expected as a result of spread of the tube characteristics, tube deterioration during life and decrease of the mains voltage to 10% below the nominal value, can be derived from the curves on page 9 by decreasing by 40% the  $I_a$  values of curve A-B at the  $V_{g2}$  value occurring at the decreased mains voltage.

In order not to exceed the maximum permissible value of  $W_{g2}$ , the circuit should be designed such that at a mains voltage of 10% below nominal,  $V_a$  at the end of scan will not be lower than the value determined by curve A-B at the relevant  $V_{g2}$  value.

**HUM**

The equivalent pentode grid hum voltage without negative feedback is max. 10 mV when  $Z_{g_1}$  (at  $f = 50$  Hz)  $\leq 0.5$  M $\Omega$ ,  $C_{g_1-f} = 0.2$  pF and  $V_{kf} = 150$  V<sub>RMS</sub>.

**LIMITING VALUES** (Design centre rating system)

Triode section

|                           |           |                           |
|---------------------------|-----------|---------------------------|
| Anode voltage             | $V_{a_0}$ | max. 550 V                |
|                           | $V_a$     | max. 300 V                |
| Anode dissipation         | $W_a$     | max. 0.5 W                |
| Cathode current           |           |                           |
| average                   | $I_k$     | max. 15 mA                |
| peak                      | $I_{k_p}$ | max. 150 mA <sup>1)</sup> |
| peak                      | $I_{k_p}$ | max. 100 mA <sup>2)</sup> |
| Grid resistor             |           |                           |
| for fixed bias            | $R_g$     | max. 1 M $\Omega$         |
| for automatic bias        | $R_g$     | max. 3.3 M $\Omega$       |
| Cathode to heater voltage | $V_{kf}$  | max. 200 V <sup>3)</sup>  |

Remark

A cathode peak current of 100 mA will be available throughout life and at under-heating.

<sup>1)</sup> Max. pulse duration 2% of a cycle with a maximum of 400  $\mu$ sec.

<sup>2)</sup> Max. pulse duration 4% of a cycle with a maximum of 800  $\mu$ sec.

<sup>3)</sup> During warming up the D.C. component of  $V_{kf} = \text{max. } 315$  V, k pos.

**LIMITING VALUES (continued)**

Pentode section

|                           |               |                          |
|---------------------------|---------------|--------------------------|
| Anode voltage             | $V_{a_0}$     | max. 550 V               |
|                           | $V_a$         | max. 300 V               |
| Anode peak voltage        | $V_{a_p}$     | max. 2 kV <sup>1)</sup>  |
| Grid No.2 voltage         | $V_{g_{2_0}}$ | max. 550 V               |
|                           | $V_{g_2}$     | max. 250 V               |
| Anode dissipation         | $W_a$         | max. 8 W <sup>2)</sup>   |
| Grid No.2 dissipation     | $W_{g_2}$     | max. 1.5 W <sup>3)</sup> |
| Cathode current           | $I_k$         | max. 75 mA               |
| Grid No.1 resistor        |               |                          |
| for fixed bias            | $R_{g_1}$     | max. 1.0 M $\Omega$      |
| for automatic bias        | $R_{g_1}$     | max. 2.2 M $\Omega$      |
| Cathode to heater voltage | $V_{kf}$      | max. 200 V               |

<sup>1)</sup> Max. pulse duration 5% of a cycle with a maximum of 1 ms.

<sup>2)</sup> For a nominal tube at the worst probable operating conditions and at normal picture height  $W_a$  should not exceed 10.5 W.

<sup>3)</sup> For a nominal tube at the worst probable operating conditions and at normal picture height  $W_{g_2}$  should not exceed 2 W.

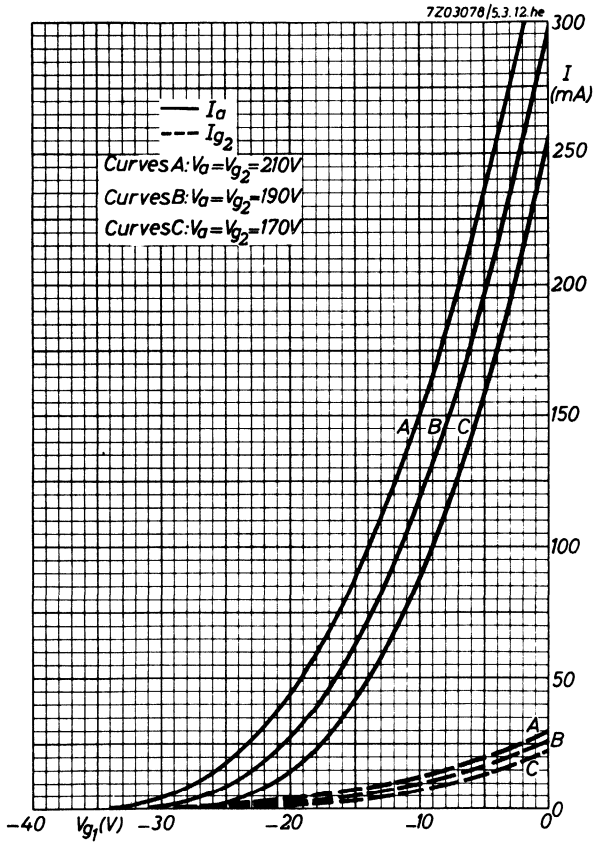

**PCL85**  
**PCL805**

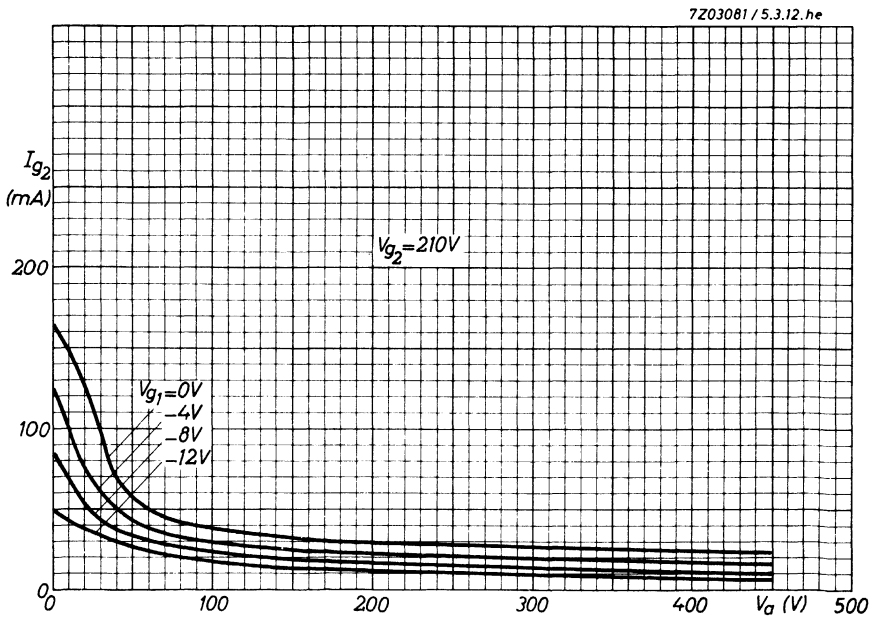
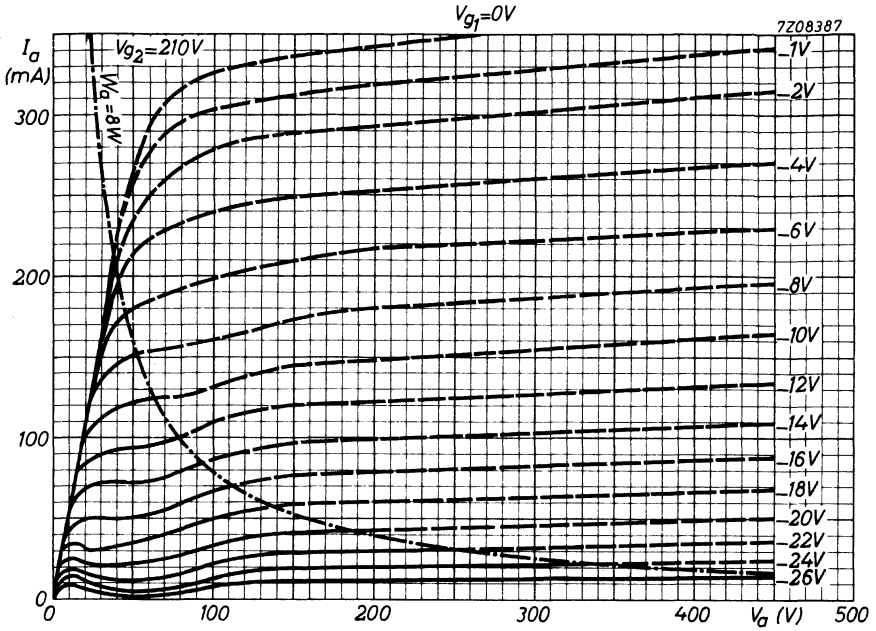



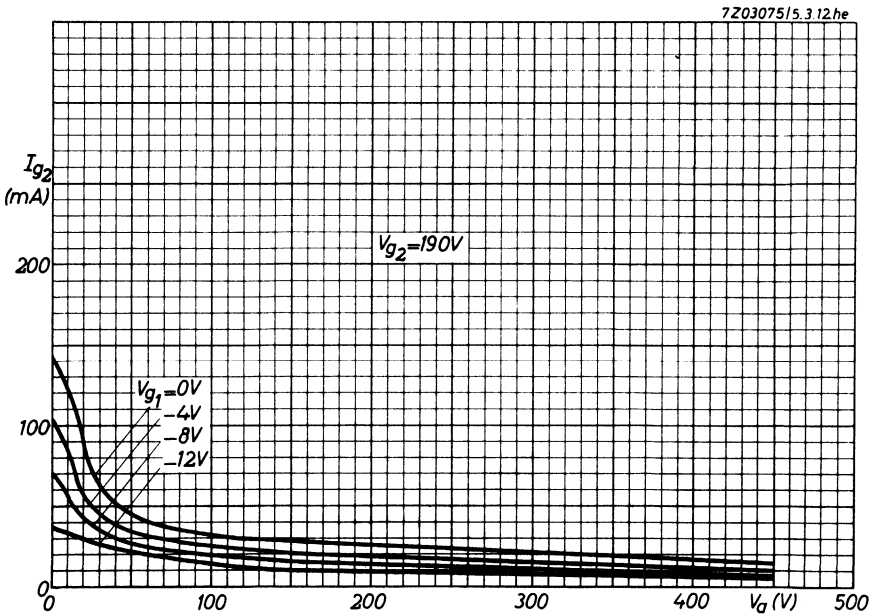
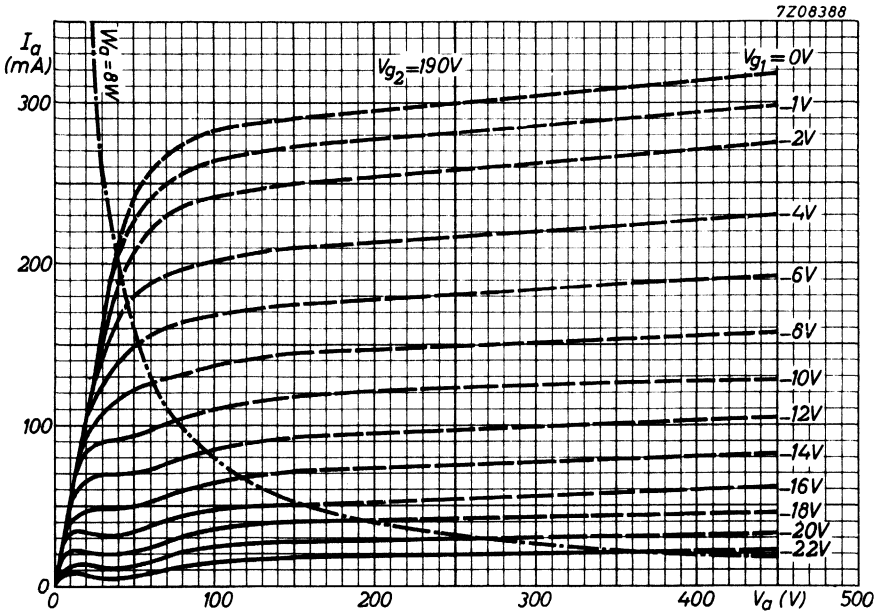

7Z08386

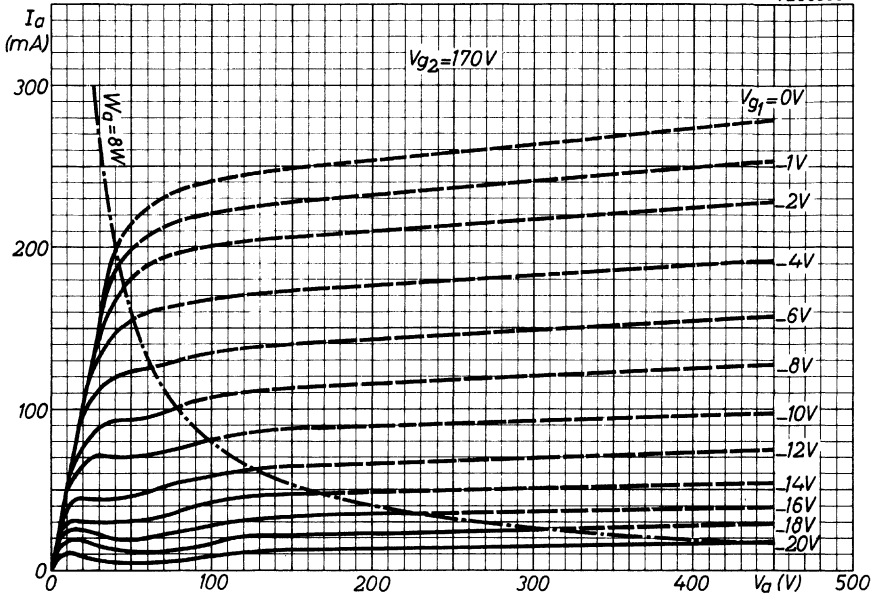

7Z03076/5.3.12.he

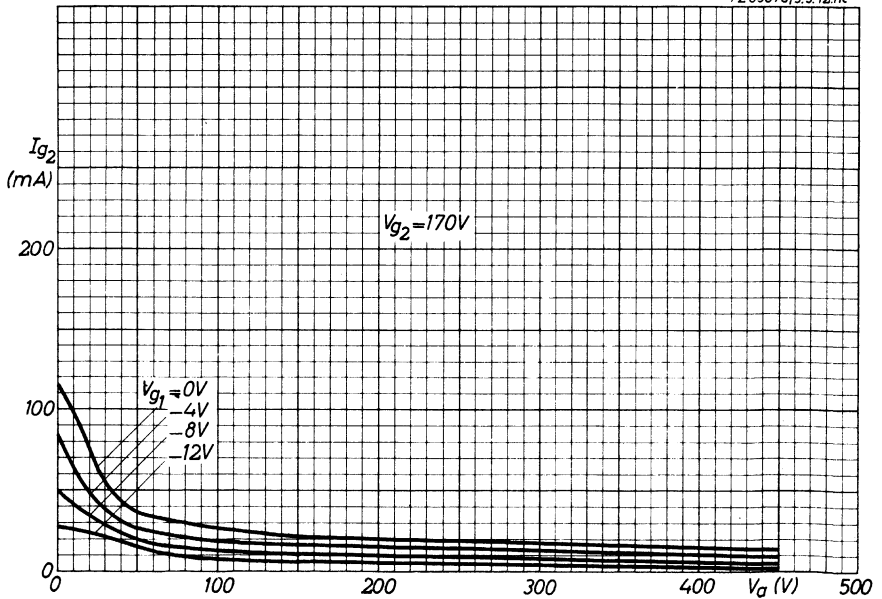

7203077/5.3.12he

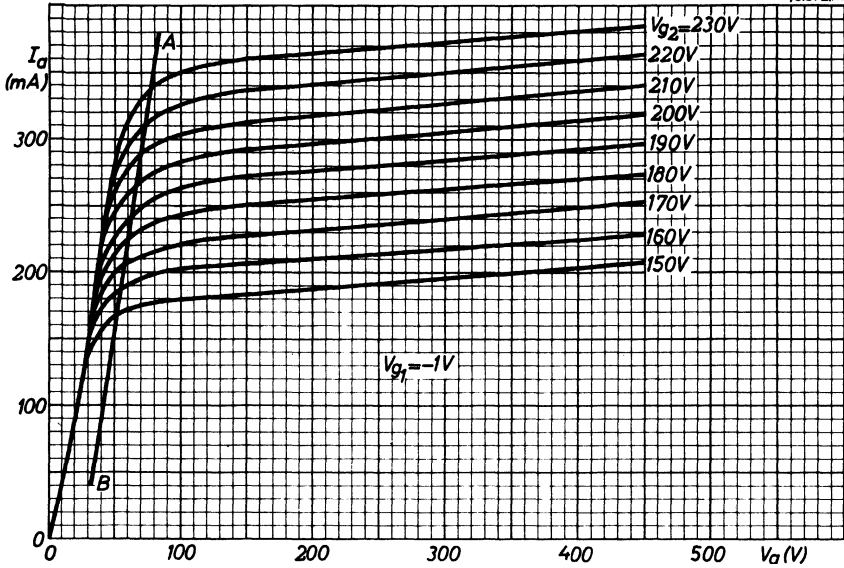

7209642

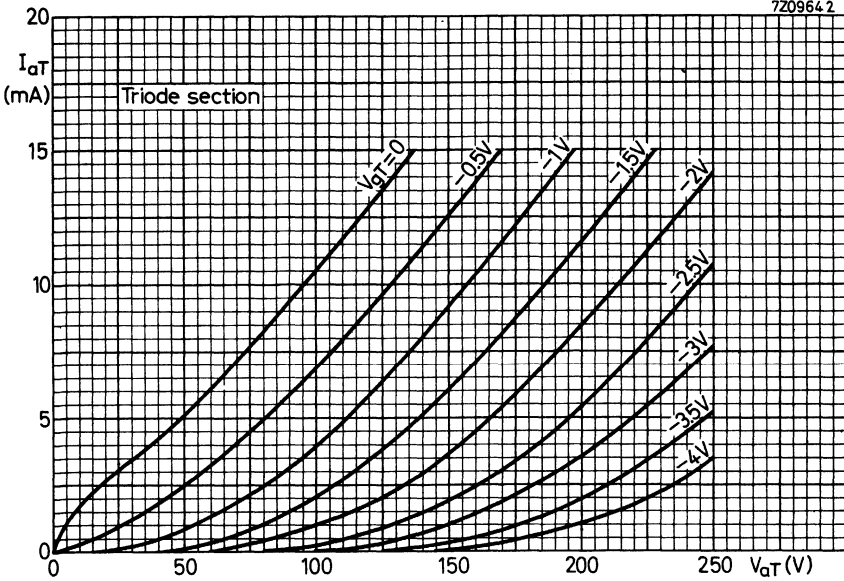

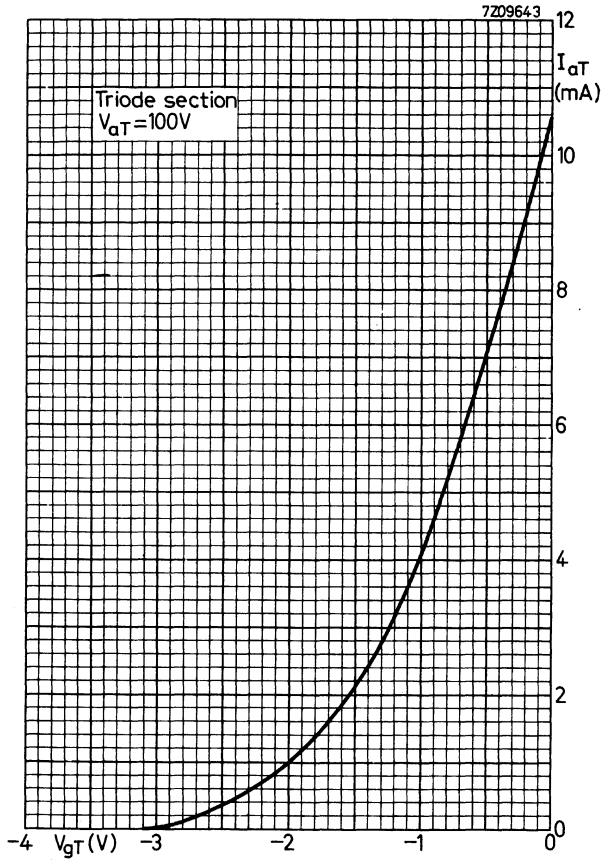

## TRIODE-OUTPUT PENTODE

Triode-pentode with separate cathodes.

The triode section is intended for use as A.F. amplifier.

The pentode section is intended for use as A.F. power amplifier.

| QUICK REFERENCE DATA   |              |           |
|------------------------|--------------|-----------|
| <u>Triode section</u>  |              |           |
| Anode current          | $I_a$        | 1.2 mA    |
| Transconductance       | $S$          | 1.6 mA/V  |
| Amplification factor   | $\mu$        | 100 -     |
| <u>Pentode section</u> |              |           |
| Anode current          | $I_a$        | 39 mA     |
| Transconductance       | $S$          | 10.5 mA/V |
| Amplification factor   | $\mu_{g2g1}$ | 21 -      |
| Output power           | $W_o$        | 4.1 W     |

**HEATING:** Indirect by A.C. or D.C.; series supply

|                |       |        |
|----------------|-------|--------|
| Heater current | $I_f$ | 300 mA |
| Heater voltage | $V_f$ | 13.3 V |

### DIMENSIONS AND CONNECTIONS

Dimensions in mm

Base: Noval

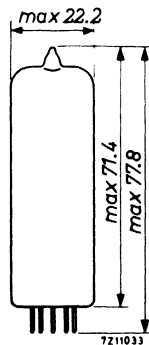
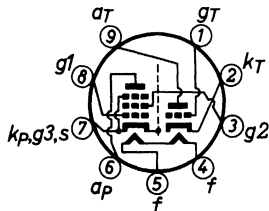

**CAPACITANCES**

Triode section

|                          |            |               |
|--------------------------|------------|---------------|
| Anode to all except grid | $C_{a(g)}$ | 2.5 pF        |
| Grid to all except anode | $C_{g(a)}$ | 2.3 pF        |
| Anode to grid            | $C_{ag}$   | 1.4 pF        |
| Grid to heater           | $C_{gf}$   | max. 0.006 pF |

Pentode section

|                                |             |              |
|--------------------------------|-------------|--------------|
| Grid No. 1 to all except anode | $C_{g1(a)}$ | 10 pF        |
| Anode to grid No. 1            | $C_{ag1}$   | max. 0.4 pF  |
| Grid No. 1 to heater           | $C_{g1f}$   | max. 0.24 pF |

Between triode and pentode sections

|                                    |             |                             |
|------------------------------------|-------------|-----------------------------|
| Anode triode to grid No. 1 pentode | $C_{aTg1P}$ | max. 0.2 pF                 |
| Grid triode to grid No. 1 pentode  | $C_{gTg1P}$ | max. 0.02 pF                |
| Anode triode to anode pentode      | $C_{aTap}$  | max. 0.15 pF                |
| Grid triode to anode pentode       | $C_{gTap}$  | max. 0.006 pF <sup>1)</sup> |

**TYPICAL CHARACTERISTICS**

Triode section

|                      |       |          |
|----------------------|-------|----------|
| Anode voltage        | $V_a$ | 230 V    |
| Grid voltage         | $V_g$ | -1.7 V   |
| Anode current        | $I_a$ | 1.2 mA   |
| Transconductance     | $S$   | 1.6 mA/V |
| Amplification factor | $\mu$ | 100      |

Pentode section

|                      |              |               |
|----------------------|--------------|---------------|
| Anode voltage        | $V_a$        | 230 V         |
| Grid No. 2 voltage   | $V_{g2}$     | 230 V         |
| Grid No. 1 voltage   | $V_{g1}$     | -5.7 V        |
| Anode current        | $I_a$        | 39 mA         |
| Grid No. 2 current   | $I_{g2}$     | 6.5 nA        |
| Transconductance     | $S$          | 10.5 mA/V     |
| Amplification factor | $\mu_{g2g1}$ | 21            |
| Internal resistance  | $R_i$        | 45 k $\Omega$ |

<sup>1)</sup> The capacitance between triode grid and pentode anode ( $C_{gT-ap}$ ) can be reduced to a value of less than 0.002 pF by using a shielding ring with a diameter of 22.5 mm and a height of 15 mm with respect to the tube base.

## OPERATING CHARACTERISTICS

Triode sectionA. F. amplifier

|                                  |           |      |      |      |      |           |
|----------------------------------|-----------|------|------|------|------|-----------|
| Supply voltage                   | $V_b$     | 200  | 230  | 200  | 230  | V         |
| Cathode resistor                 | $R_k$     | 0    | 0    | 2.6  | 2.1  | $k\Omega$ |
| Anode resistor                   | $R_a$     | 220  | 220  | 220  | 220  | $k\Omega$ |
| Grid resistor                    | $R_g$     | 10   | 10   | -    | -    | $M\Omega$ |
| Grid resistor of following stage | $R_{g'}$  | 680  | 680  | 680  | 680  | $k\Omega$ |
| Signal source resistance         | $R_s$     | 47   | 47   | -    | -    | $k\Omega$ |
| Anode current                    | $I_a$     | 0.42 | 0.52 | 0.42 | 0.52 | mA        |
| Output voltage                   | $V_o$     | 3.2  | 3.2  | 3.2  | 3.2  | $V_{RMS}$ |
| Voltage gain                     | $V_o/V_i$ | 66   | 68   | 66   | 68   |           |
| Distortion                       | $d_{tot}$ | 0.6  | 0.5  | 0.6  | 0.5  | %         |

Microphony

The triode section can be used without special precautions against microphonic effect in circuits in which an output of 50 mW is obtained at an input voltage of not less than 10 mV<sub>RMS</sub>.

Hum

The hum level will be better than 60 dB under the following conditions;

Input voltage minimum 10 mV<sub>RMS</sub> for 50 mW output.

Grid circuit impedance max. 0.5 M $\Omega$  at 50 Hz.

Cathode decoupling capacitor minimum 100  $\mu$ F.

Pin 4 connected to earth.

A.C. voltage between pin 4 and cathode max. 30 V<sub>RMS</sub>.

OPERATING CHARACTERISTICS

Pentode section

Class A (Measured with  $V_k$  constant)

|                            |             |            |            |           |
|----------------------------|-------------|------------|------------|-----------|
| Anode voltage              | $V_a$       | 200        | 230        | V         |
| Grid No. 2 voltage         | $V_{g2}$    | 200        | 230        | V         |
| Cathode resistor           | $R_k$       | 115        | 125        | $\Omega$  |
| (Grid No. 1 voltage)       | $V_{g1}$    | -4.7       | -5.7       | V)        |
| Load resistance            | $R_{a\sim}$ | 5.6        | 5.1        | $k\Omega$ |
| Grid No. 1 driving voltage | $V_i$       | 0 0.32 3.2 | 0 0.34 3.6 | $V_{RMS}$ |
| Anode current              | $I_a$       | 35 - 34    | 39 - 40.7  | mA        |
| Grid No. 2 current         | $I_{g2}$    | 6.0 - 9.0  | 6.5 - 10.5 | mA        |
| Output power               | $W_o$       | 0 0.05 3.1 | 0 0.05 4.1 | W         |
| Distortion                 | $d_{tot}$   | - 0.9 10   | - 0.9 10   | %         |





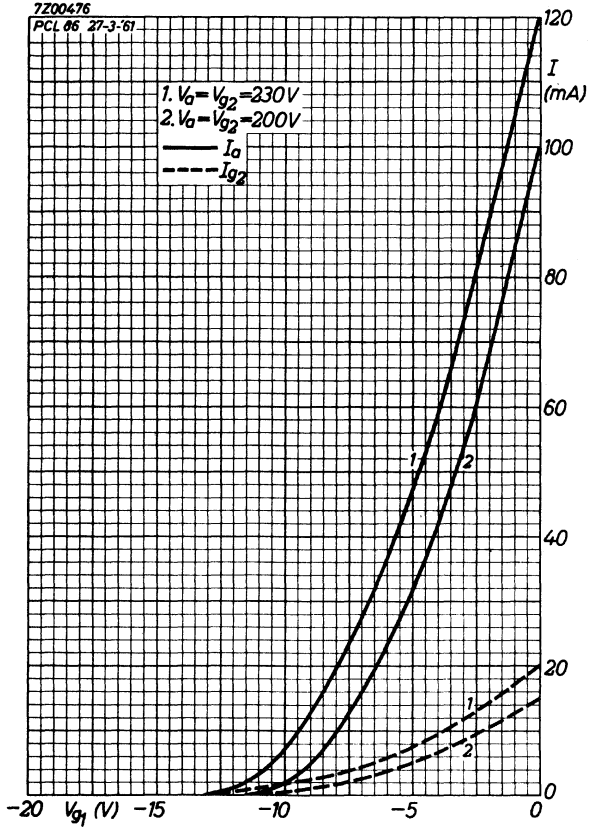

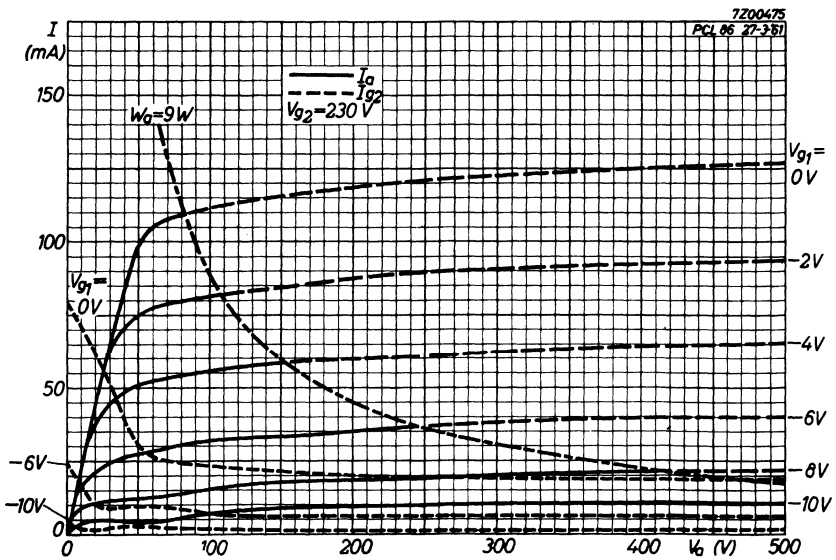
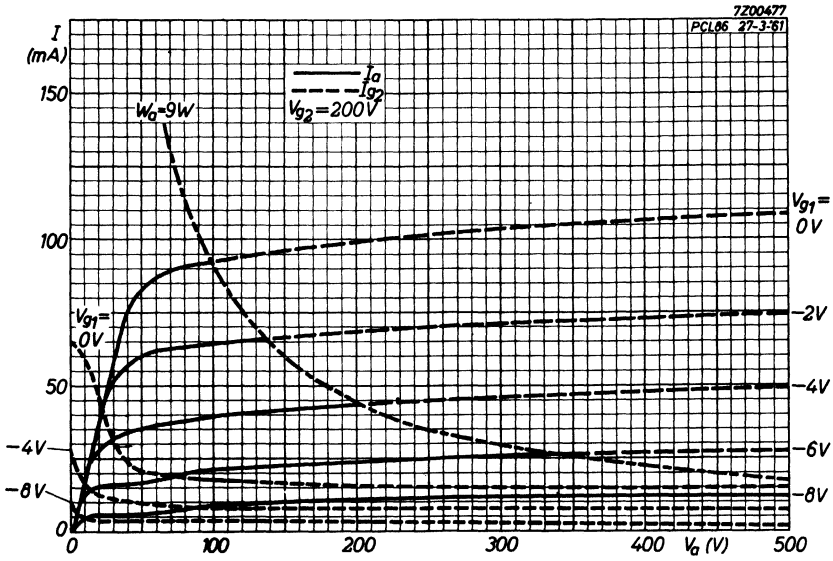

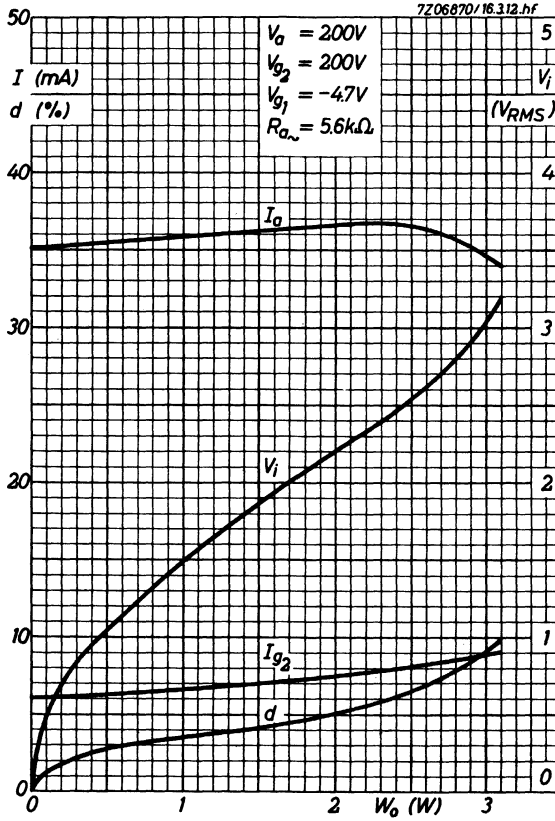

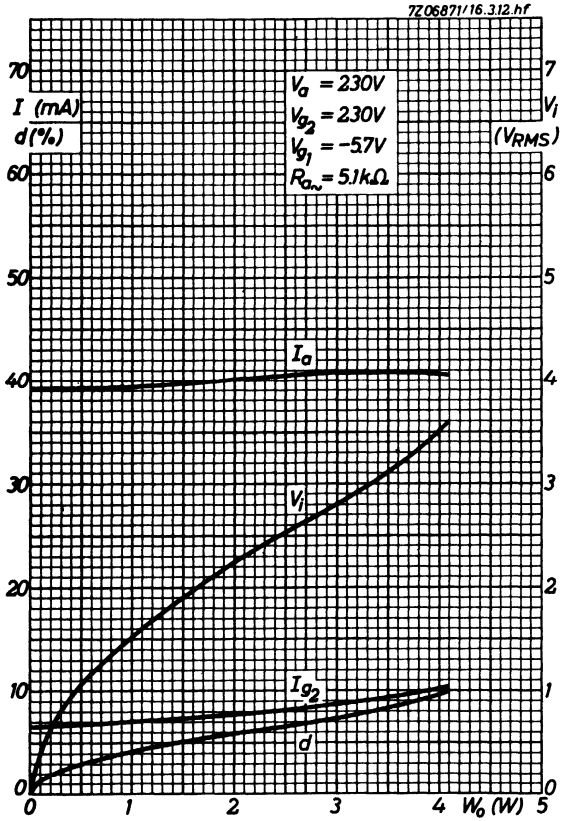

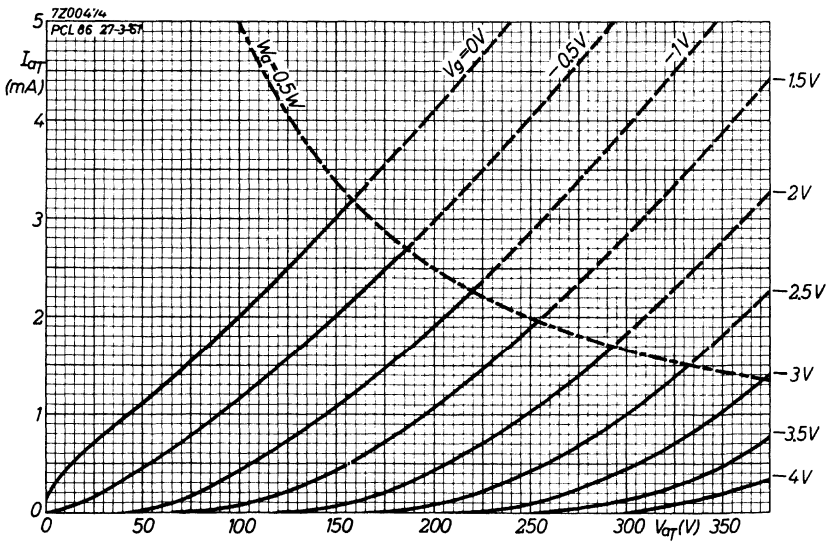
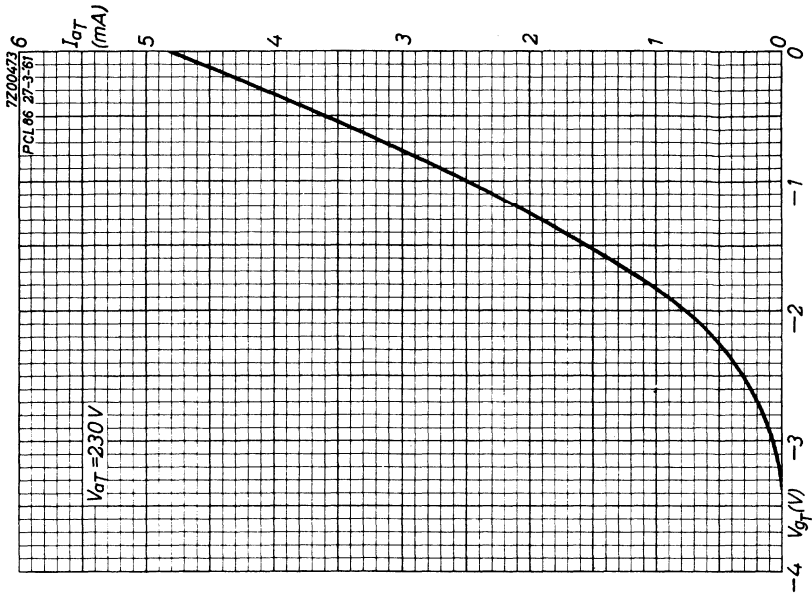

## SHUNT STABILIZER TRIODE

Shunt stabilizer triode intended for use as in colour TV receivers.

### QUICK REFERENCE DATA

|               |       |             |
|---------------|-------|-------------|
| Anode voltage | $V_a$ | 25 kV       |
| Anode current | $I_a$ | max. 1.6 mA |

**HEATING:** Indirect by A.C. or D.C.; series supply

|                |       |        |
|----------------|-------|--------|
| Heater current | $I_f$ | 300 mA |
| Heater voltage | $V_f$ | 7.3 V  |

### DIMENSIONS AND CONNECTIONS

Dimensions in mm

Base: Magnoval

Top cap: Type 2

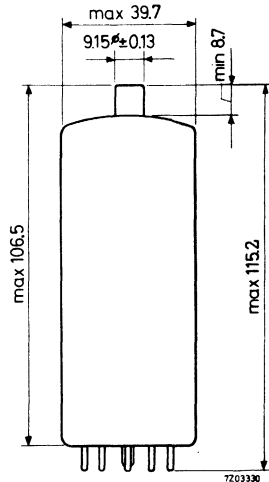
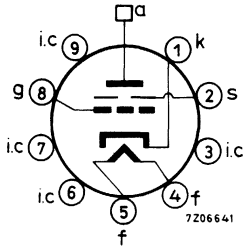

Mounting: Additional supporting of the tube at the top is required.

To prevent corona-effects any metal screening applied around the tube should be at least 5 cm from the nearest point of the bulb.

Adequate ventilation should be provided for.

### TYPICAL CHARACTERISTICS

|  |              |             |
|--|--------------|-------------|
| Anode voltage  | $V_a$        | 25 kV       |
| Screen voltage   | $V_s$        | 0 V         |
| Grid voltage change for an anode current change from 0.1 to 1.5 mA | $\Delta V_g$ | max. 10 V   |
| Grid voltage at $I_a = 1.5$ mA                                     | $V_g$        | -7 to -30 V |
| at $I_a = 0.1$ mA  | $V_g$        | max. -40 V  |

**LIMITING VALUES** (Design centre rating system unless otherwise specified)

|   |           |      |  |
|---|-----------|------|--|
| Anode voltage                             | $V_a$     | max. | 25 kV                                    |
| Anode voltage (absolute max.)             | $V_a$     | max. | 27.5 kV <sup>1)</sup>                    |
| Anode current                             | $I_a$     | max. | 1.6 mA                                   |
| Anode dissipation                         | $W_a$     | max. | 30 W                                     |
| Anode dissipation (absolute max.)         | $W_a$     | max. | 40 W <sup>2)</sup>                       |
| Negative grid voltage                     | $-V_g$    | max. | 150 V <sup>3)</sup>                      |
| Grid resistor                             | $R_g$     | max. | 5 M $\Omega$                             |
| Cathode to heater voltage                 |           |      |  |
| cathode positive                          | $V_{kf}$  | max. | 400 V <sub>DC</sub> +250 V <sub>AC</sub> |
| cathode negative                          | $-V_{kf}$ | max. | 250 V                                    |
| Screen voltage                            | $V_s$     | max. | 0 V                                      |
|   | $-V_s$    | max. | 400 V <sup>4)</sup>                      |
| Anode seal temperature<br>(absolute max.) | $t_s$     | max. | 200 °C                                   |

Precaution: x-ray shielding may be required to give protection against excessive radiation.

- 1) If due to a circuit failure the anode current becomes 0 mA the anode voltage should never exceed 45 kV (abs. max.)
- 2) Permissible only during short periods; in total up to a maximum of 10% of the operation time of the tube.
- 3) During equipment warm-up and for brief interval during receiver adjustment this voltage may rise to 440 V max.
- 4) The screen connected to pin 2 is provided to shield grid and cathode from the high anode voltage.  
It is recommended to connect the screen directly to earth, with a minimum lead inductance.  
The modulating influence of possible hum ripple of the screen to cathode voltage should be taken into account; the sensitivity for these variations in  $V_s/k$  is 2.5  $\mu A/V$  max.



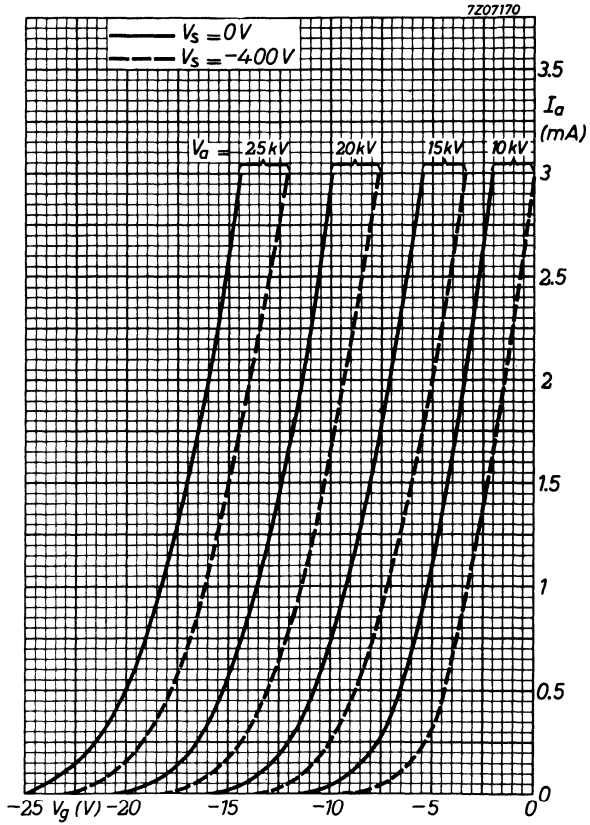



## SHUNT STABILIZER TRIODE

Shunt stabilizer triode intended for use in colour TV receivers.

**HEATING:** Indirect by A.C. or D.C.; series supply

Heater current  
Heater voltage

$$\frac{I_f}{V_f} = \frac{300 \text{ mA}}{7.3 \text{ V}}$$

### DIMENSIONS AND CONNECTIONS

Dimensions in mm.

Base: Magnoval

Top cap: Type 2

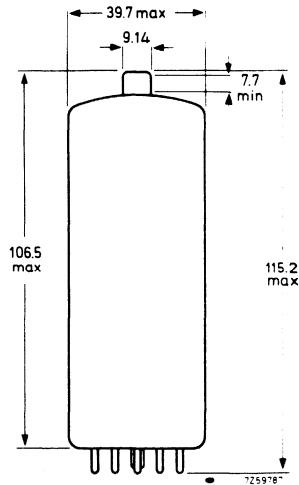
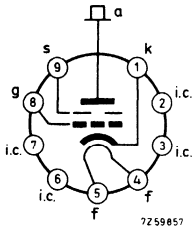

**Mounting:** Additional supporting of the tube at the top is required. To prevent corona effects any metal screening applied around the tube should be at least 5 cm from the nearest point of the bulb. Adequate ventilation should be provided for.

### TYPICAL CHARACTERISTICS

|   |              |           |    |
|---|--------------|-----------|----|
| Anode voltage   | $V_a$        | 25        | kV |
| Screen voltage  | $V_s$        | 0         | V  |
| Grid voltage change for an anode current change from 0.1 mA to 1.5 mA | $\Delta V_g$ | max. 10   | V  |
| Grid voltage at $I_a = 1.5$ mA  | $V_g$        | -9 to -28 | V  |
| at $I_a = 0.1$ mA   | $V_g$        | max. -38  | V  |

Data based on pre-production tubes

**LIMITING VALUES** (Design centre rating system unless otherwise specified)

|   |           |      |                             |                  |
|---|-----------|------|-----------------------------|------------------|
| Anode voltage                             | $V_a$     | max. | 25                          | kV               |
| Anode voltage (absolute max.)             | $V_a$     | max. | 27.5                        | kV <sup>1)</sup> |
| Anode current                             | $I_a$     | max. | 1.6                         | mA               |
| Anode dissipation                         | $W_a$     | max. | 30                          | W                |
| Anode dissipation (absolute max.)         | $W_a$     | max. | 40                          | W <sup>2)</sup>  |
| Negative grid voltage                     | $-V_g$    | max. | 150                         | V <sup>3)</sup>  |
| Grid resistor                             | $R_g$     | max. | 5                           | M $\Omega$       |
| Cathode to heater voltage                 |           |      |                             |                  |
| cathode positive                          | $V_{kf}$  | max. | 400 $V_{DC}$ + 250 $V_{AC}$ |                  |
| cathode negative                          | $-V_{kf}$ | max. | 250                         | V                |
| Screen voltage                            | $V_s$     | max. | 0                           | V                |
|   | $-V_s$    | max. | 50                          | V <sup>4)</sup>  |
| Anode seal temperature<br>(absolute max.) | $t_s$     | max. | 200                         | $^{\circ}C$      |

**X-RAYS**

When operating this tube will produce X-radiation, and a suitable screen may be required.

Because of the difference in X-ray characteristics the PD510 should never be replaced by a PD500 in equipment designed for the PD510.

- 
- 1) If due to a circuit failure the anode current becomes 0 mA the anode voltage should never exceed 45 kV (abs. max.)
  - 2) Permissible only during short periods; in total up to a maximum of 10% of the operation time of the tube.
  - 3) During equipment warm-up and for brief interval during receiver adjustment this voltage may rise to 440 V max.
  - 4) The screen connected to pin 9 is provided to shield grid and cathode from the high anode voltage.  
It is recommended to connect the screen directly to earth, with a minimum lead inductance.

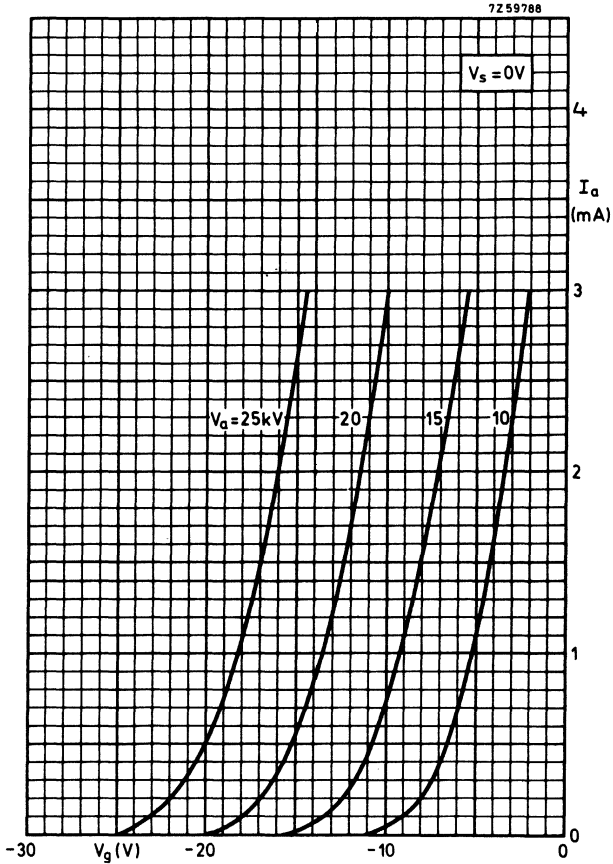



**TYPICAL CHARACTERISTICS**

|                      |              |           |      |            |
|----------------------|--------------|-----------|------|------------|
| Anode voltage        | $V_a$        | 100       | 250  | V          |
| Grid No. 3 voltage   | $V_{g3}$     | -30       | 0    | V          |
| Grid No. 2 voltage   | $V_{g2}$     | 35        | 140  | V          |
| Grid No. 1 voltage   | $V_{g1}$     | 0         | -2.2 | V          |
| Anode current        | $I_a$        | max. 0.01 | 3.0  | mA         |
| Grid No. 2 current   | $I_{g2}$     |           | 0.6  | mA         |
| Transconductance     | $S$          |           | 2.2  | mA/V       |
| Amplification factor | $\mu_{g2g1}$ |           | 38   | -          |
| Internal resistance  | $R_i$        |           | 2.5  | M $\Omega$ |

**LIMITING VALUES** (Design centre rating system)

|                                      |                  |          |      |                     |
|--------------------------------------|------------------|----------|------|---------------------|
| Anode voltage                        | $V_{a0}$         | max.     | 550  | V                   |
|                                      | $V_a$            | max.     | 300  | V                   |
| Anode dissipation                    | $W_a$            | max.     | 1    | W                   |
| Grid No. 2 voltage                   | $V_{g20}$        | max.     | 550  | V                   |
|                                      | $V_{g2}$         | max.     | 200  | V                   |
| Grid No. 2 dissipation               | $W_{g2}$         | max.     | 0.2  | W                   |
| Cathode current, average             | $I_k$            | max.     | 4    | mA                  |
|                                      | peak             | $I_{kp}$ | max. | 25 mA <sup>1)</sup> |
| Grid No. 1 resistor ( $W_a < 0.2$ W) | $R_{g1}$         | max.     | 10   | M $\Omega$          |
|                                      | ( $W_a > 0.2$ W) | $R_{g1}$ | max. | 3                   |
| Grid No. 3 resistor                  | $R_{g3}$         | max.     | 0.1  | M $\Omega$          |
| Cathode to heater voltage            | $V_{kf}$         | max.     | 100  | V                   |

<sup>1)</sup> Max. pulse duration 4% of a cycle but max. 0.8 ms.

## PENTODE

Pentode intended for use in transistron circuits in television receivers.

| QUICK REFERENCE DATA |                |     |            |
|----------------------|----------------|-----|------------|
| Anode current        | $I_a$          | 3.0 | mA         |
| Transconductance     | $S$            | 2.2 | mA/V       |
| Amplification factor | $\mu_{g_2g_1}$ | 38  | -          |
| Internal resistance  | $R_i$          | 2.5 | M $\Omega$ |

**HEATING:** Indirect by A.C. or D.C.; series supply

|                |       |     |    |
|----------------|-------|-----|----|
| Heater current | $I_f$ | 300 | mA |
| Heater voltage | $V_f$ | 4.5 | V  |

### DIMENSIONS AND CONNECTIONS

Dimensions in mm

Base: Noval

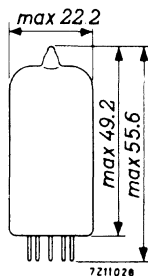
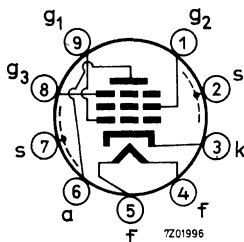

### CAPACITANCES

|                                |              |           |    |
|--------------------------------|--------------|-----------|----|
| Anode to all except grid No. 1 | $C_a(g_1)$   | 5.1       | pF |
| Grid No. 1 except anode        | $C_{g_1(a)}$ | 3.5       | pF |
| Anode to grid No. 1            | $C_{ag_1}$   | max. 0.07 | pF |
| Grid No. 1 to heater           | $C_{g_1f}$   | max. 0.03 | pF |



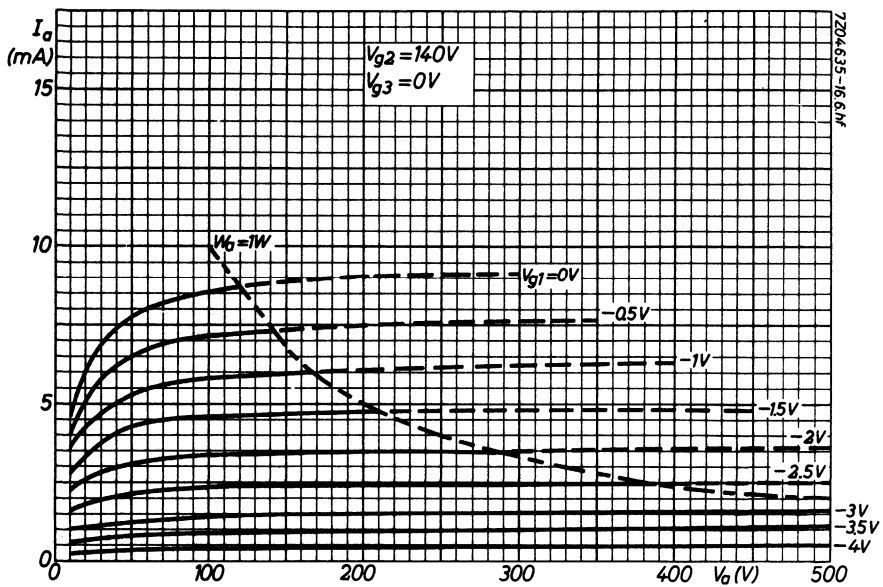

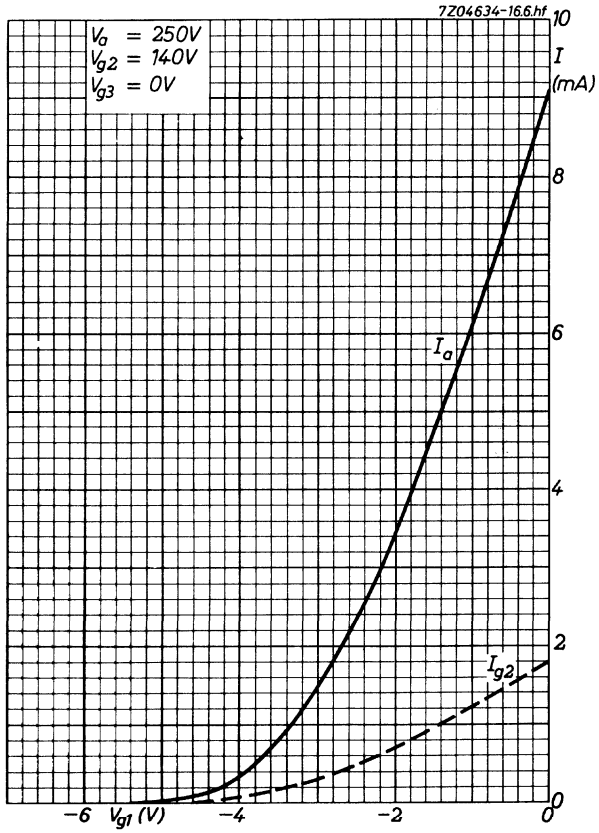

## DOUBLE PENTODE

Double pentode intended for use as video output tube, sync. separator, A.C. amplifier or I.F. sound amplifier.

| <b>QUICK REFERENCE DATA</b> |                |  |                |
|-----------------------------|----------------|--|----------------|
| <u>F section</u>            |                |  |                |
| Anode current               | $I_a$          |  | 10 mA          |
| Transconductance            | $S$            |  | 8.5 mA/V       |
| Amplification factor        | $\mu_{g_2g_1}$ |  | 38 -           |
| Internal resistance         | $R_i$          |  | 150 k $\Omega$ |
| <u>L section</u>            |                |  |                |
| Anode current               | $I_a$          |  | 30 mA          |
| Transconductance            | $S$            |  | 22 mA/V        |
| Amplification factor        | $\mu_{g_2g_1}$ |  | 38 -           |
| Internal resistance         | $R_i$          |  | 33 k $\Omega$  |

**HEATING:** Indirect by A.C. or D.C.; series supply

|                |              |
|----------------|--------------|
| Heater current | $I_f$ 300 mA |
| Heater voltage | $V_f$ 17 V   |

**DIMENSIONS AND CONNECTIONS**

Dimensions in mm

Base: Decal

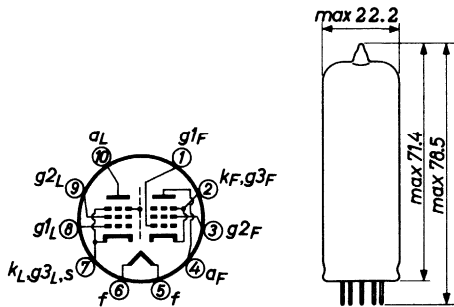

**CAPACITANCES**

|                               | L section         | F section    |
|-------------------------------|-------------------|--------------|
| Anode to all except grid No.1 | $C_{a(g_1)}$ 6.5  | 10.5 pF      |
| Grid No.1 to all except anode | $C_{g_1(a)}$ 12.5 | 10.5 pF      |
| Anode to grid No.1            | $C_{ag_1}$ 0.100  | 0.15 pF      |
| Grid No.1 to heater           | $C_{g_1f}$        | max. 0.15 pF |

Between the two pentode sections

|  |                   |               |
|--|-------------------|---------------|
| Anode L section to anode F section         | $C_{a_L a_F}$     | max. 0.15 pF  |
| Grid No.1 L section to grid No.1 F section | $C_{g_1 L g_1 F}$ | max. 0.01 pF  |
| Anode L section to grid No.1 F section     | $C_{a_L g_1 F}$   | max. 0.10 pF  |
| Grid No.1 L section to anode F section     | $C_{g_1 L a_F}$   | max. 0.005 pF |

**TYPICAL CHARACTERISTICS**

Output pentode (L section)

|                      |                 |         |
|----------------------|-----------------|---------|
| Anode voltage        | $V_a$           | 170 V   |
| Grid No.2 voltage    | $V_{g_2}$       | 170 V   |
| Grid No.1 voltage    | $V_{g_1}$       | -2.7 V  |
| Anode current        | $I_a$           | 30 mA   |
| Grid No.2 current    | $I_{g_2}$       | 7 mA    |
| Transconductance     | S               | 22 mA/V |
| Internal resistance  | $R_i$           | 33 kΩ   |
| Amplification factor | $\mu_{g_2 g_1}$ | 38 -    |

Amplifier pentode (F section)

|                      |                 |          |
|----------------------|-----------------|----------|
| Anode voltage        | $V_a$           | 150 V    |
| Grid No.2 voltage    | $V_{g_2}$       | 150 V    |
| Grid No.1 voltage    | $V_{g_1}$       | -2.1 V   |
| Anode current        | $I_a$           | 10 mA    |
| Grid No.2 current    | $I_{g_2}$       | 3.0 mA   |
| Transconductance     | S               | 8.5 mA/V |
| Internal resistance  | $R_i$           | 150 kΩ   |
| Amplification factor | $\mu_{g_2 g_1}$ | 38 -     |

**OPERATING CHARACTERISTICS**

Output pentode (L section) as video output tube

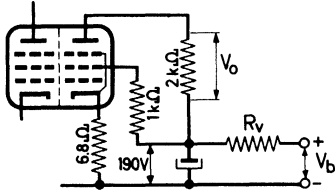

Supply voltage  $V_b = 210 \quad 230 \text{ V}$

Series resistor  $R_v = 390 \quad 820 \ \Omega$

$R_v$  should be added to avoid excessive dissipation

Input voltage (peak to peak)

$V_{ip-p} = 3.6 \text{ V}$

Output voltage (peak to peak)

$V_{op-p} = 100 \text{ V}$

Amplifier pentode (F section)

|                     |          | Sync Separator | A.G.C. amplifier | I.F. amplifier |
|---------------------|----------|----------------|------------------|----------------|
| Supply voltage      | $V_b$    | 200 to 250 V   |                  |                |
| Anode resistor      | $R_a$    | 50 k $\Omega$  |                  |                |
| Anode voltage       | $V_a$    |                | 100 to 150 V     | 150 V          |
| Grid No. 2 voltage  | $V_{g2}$ | 75 V           | 60 V             | 150 V          |
| Grid No. 1 resistor | $R_{g1}$ | 1 M $\Omega$   |                  |                |
| Grid No. 1 voltage  | $V_{g1}$ | -2.7 V         | -1.5 V           | -2.1 V         |
| Anode current       | $I_a$    | 0.1 mA         | 1 mA             | 10 mA          |
| Transconductance    | S        | 0.2 mA/V       | 2.0 mA/V         | 8.5 mA/V       |

**LIMITING VALUES** (Design centre rating system)

Output pentode (L section)

|                           |           |                          |
|---------------------------|-----------|--------------------------|
| Anode voltage             | $V_{a0}$  | max. 550 V               |
|                           | $V_a$     | max. 250 V               |
| Anode dissipation         | $W_a$     | max. 5.1 W               |
| Grid No.2 voltage         | $V_{g20}$ | max. 550 V               |
|                           | $V_{g2}$  | max. 250 V               |
| Grid No.2 dissipation     | $W_{g2}$  | max. 2.5 W <sup>1)</sup> |
| Grid No.1 resistor        | $R_{g1}$  | max. 1 M $\Omega$        |
| Cathode current           | $I_k$     | max. 60 mA <sup>2)</sup> |
| Cathode to heater voltage | $V_{kf}$  | max. 200 V               |

Amplifier pentode (F section)

|                                       |           |                          |
|---------------------------------------|-----------|--------------------------|
| Anode voltage, peak ( $I_a < 0.1$ mA) | $V_{ap}$  | max. 600 V <sup>3)</sup> |
|                                       | $V_{a0}$  | max. 550 V               |
|                                       | $V_a$     | max. 250 V               |
| Anode dissipation                     | $W_a$     | max. 1.5 W               |
| Grid No.2 voltage                     | $V_{g20}$ | max. 550 V               |
|                                       | $V_{g2}$  | max. 250 V               |
| Grid No.2 dissipation                 | $W_{g2}$  | max. 0.5 W               |
| Grid No.1 resistor                    | $R_{g1}$  | max. 1 M $\Omega$        |
| Cathode current                       | $I_k$     | max. 15 mA               |
| Cathode to heater voltage             | $V_{kf}$  | max. 200 V               |

<sup>1)</sup> During short periods  $W_{g2} = \text{max. } 3.2 \text{ W}$

<sup>2)</sup> During short periods  $I_k = \text{max. } 85 \text{ mA}$

<sup>3)</sup> Max. pulse duration 18% of a cycle, with a max. of 18  $\mu\text{sec}$ .

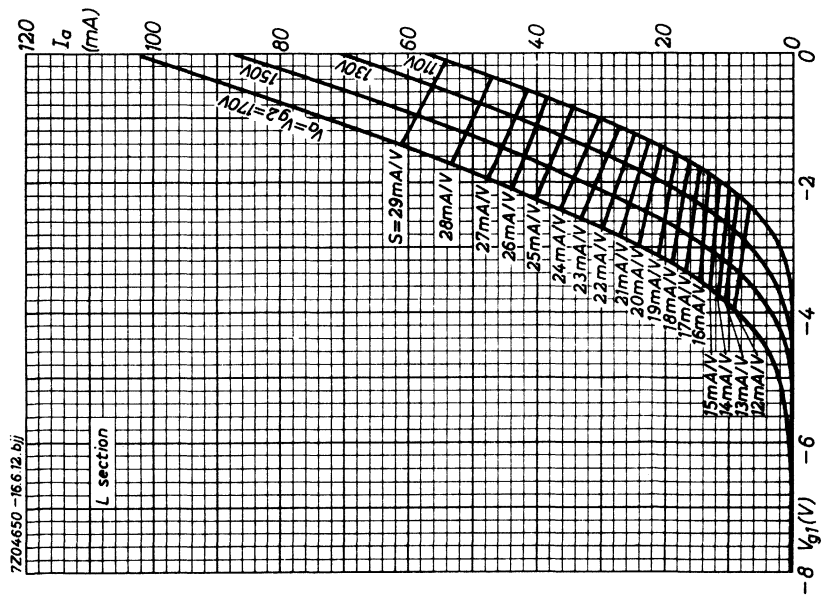
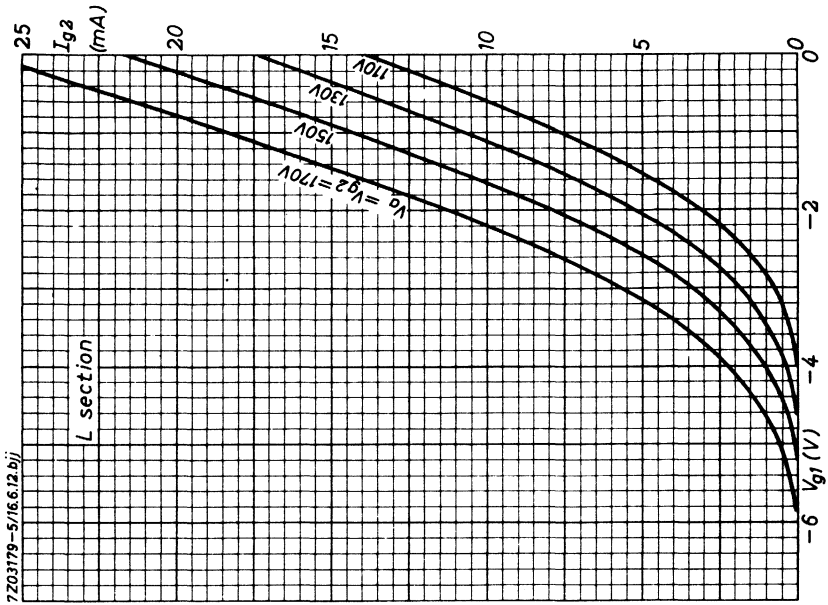

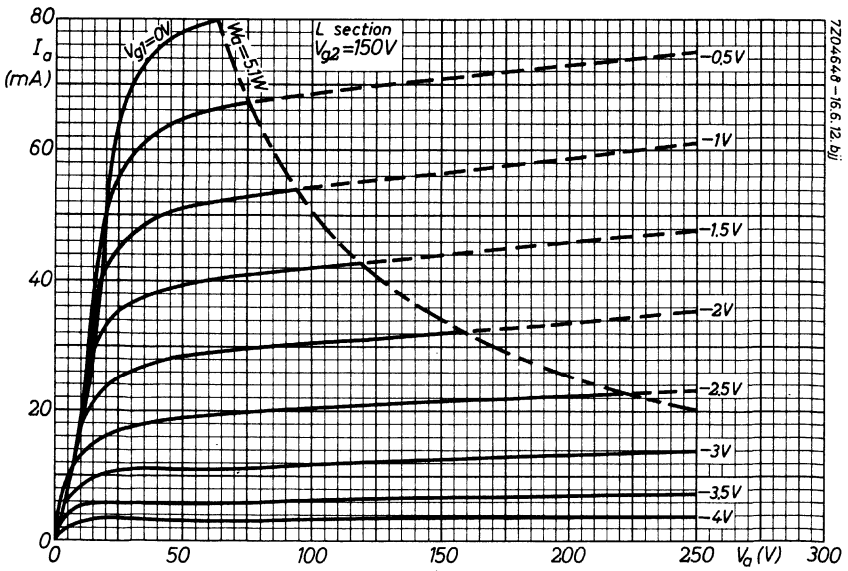
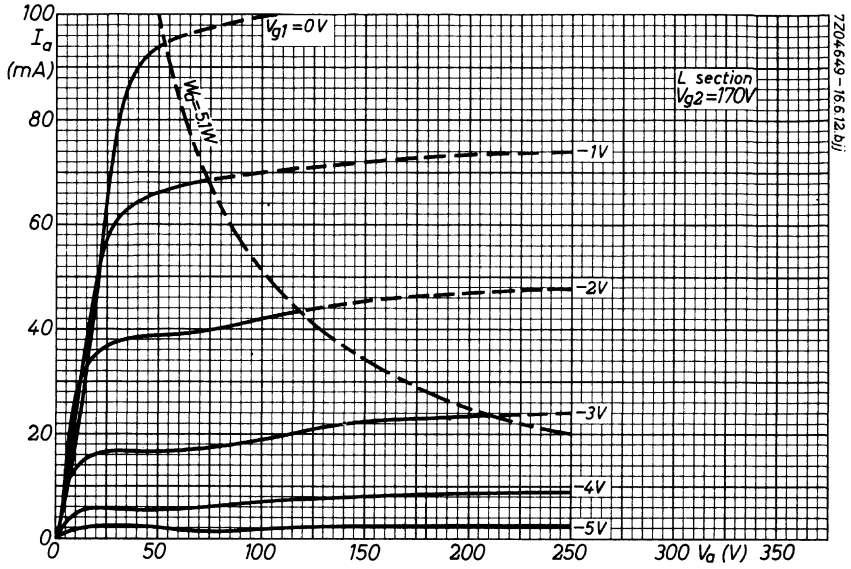



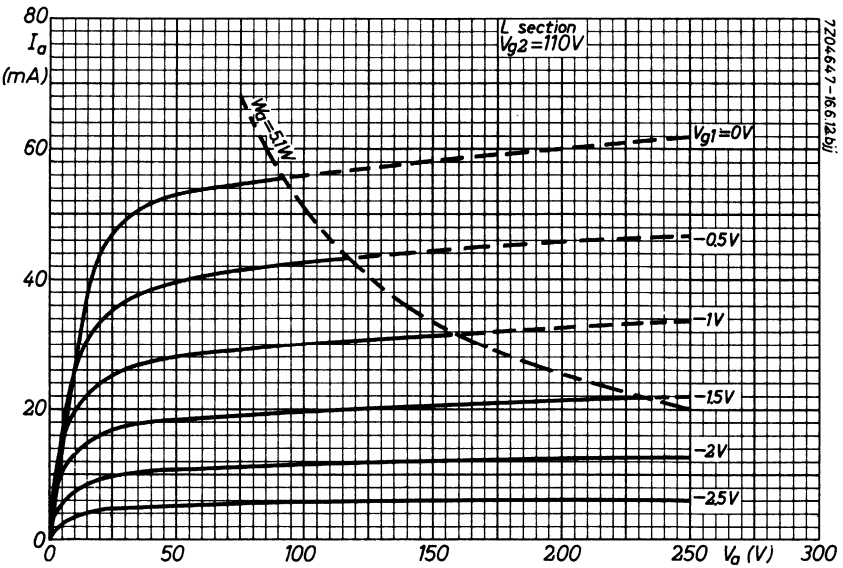
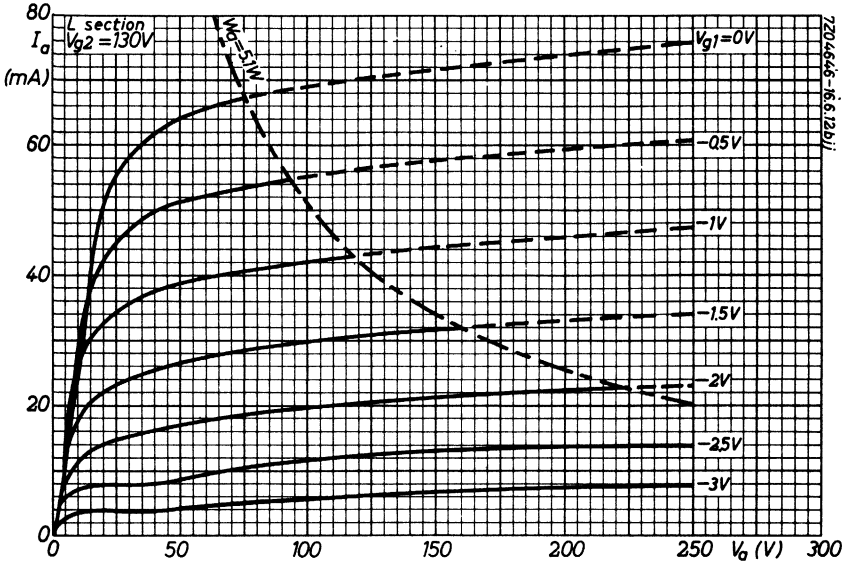

7203176-5/16.6.12.bjj

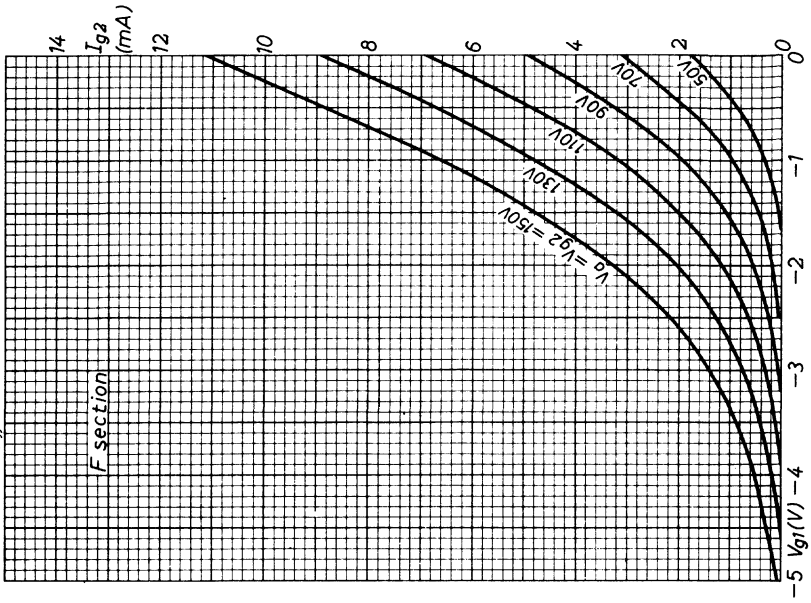

7203177-5/16.6.12.bjj

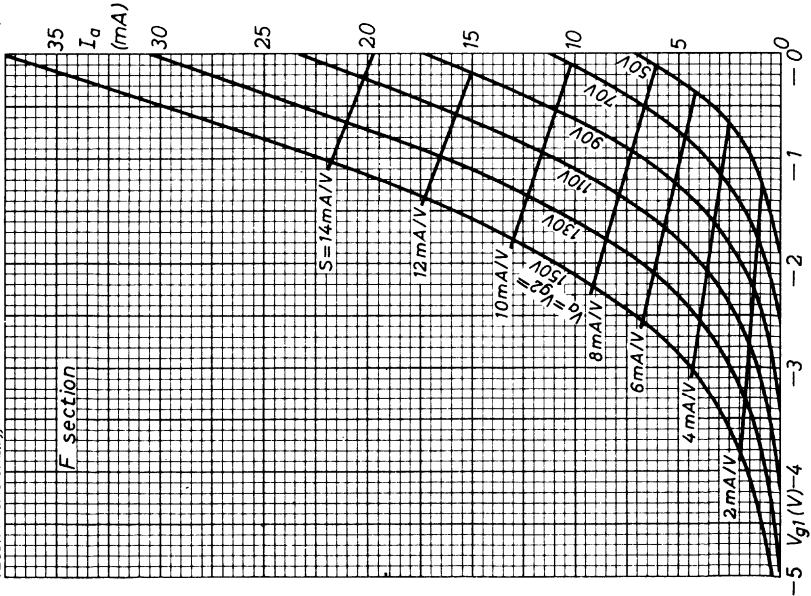

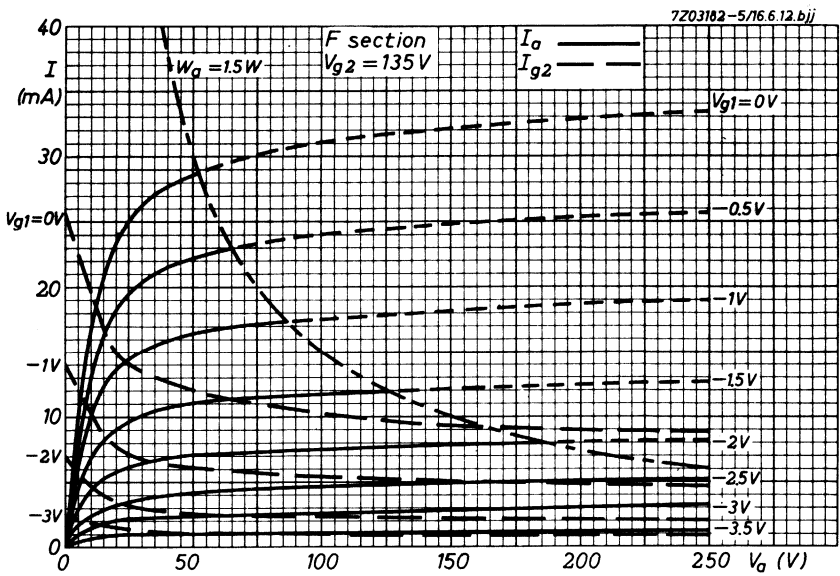
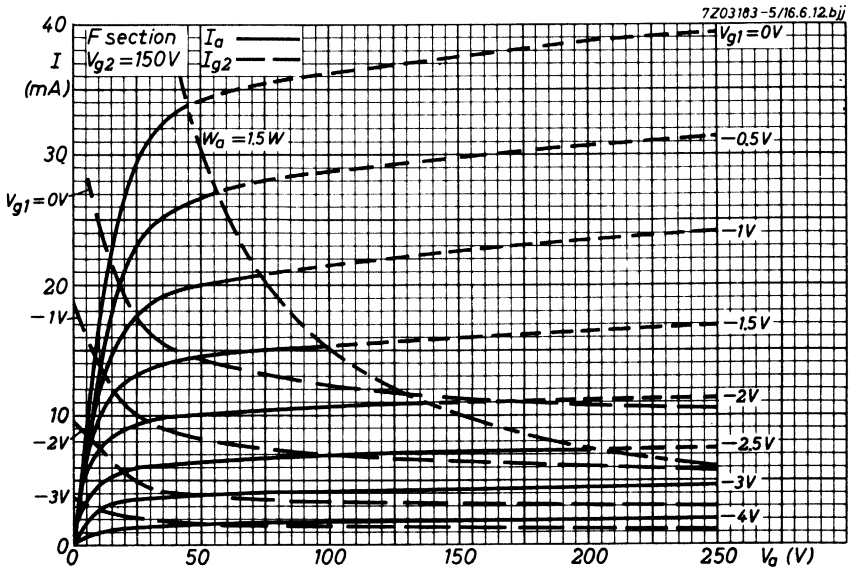

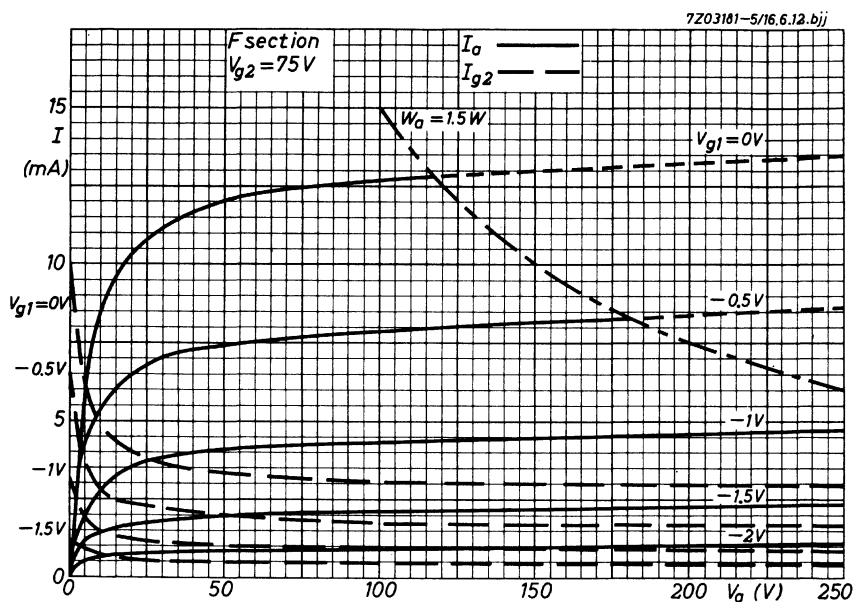

## LINE OUTPUT PENTODE

Pentode intended for use as line output tube in television receivers.

| QUICK REFERENCE DATA      |           |             |
|---------------------------|-----------|-------------|
| Anode peak voltage        | $V_{a_p}$ | max. 7 kV   |
| Cathode current           | $I_k$     | max. 200 mA |
| Drive at $V_{a_p} = 7$ kV |           | min. 120 V  |

**HEATING:** Indirect by A. C. or D. C.; series supply

|                |       |        |
|----------------|-------|--------|
| Heater current | $I_f$ | 300 mA |
| Heater voltage | $V_f$ | 25 V   |

### DIMENSIONS AND CONNECTIONS

Base: Octal

Top cap: Type 1

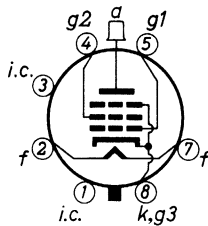

Dimensions in mm

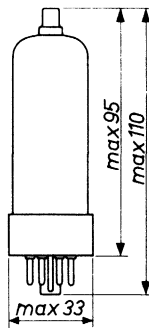

### CAPACITANCES

|                                |              |             |
|--------------------------------|--------------|-------------|
| Anode to all except grid No. 1 | $C_a(g_1)$   | 8 pF        |
| Grid No. 1 to all except anode | $C_{g_1(a)}$ | 17.5 pF     |
| Anode to grid No. 1            | $C_{ag_1}$   | max. 1.1 pF |

**TYPICAL CHARACTERISTICS**

|                      |              |              |
|----------------------|--------------|--------------|
| Anode voltage        | $V_a$        | 100 V        |
| Grid No.2 voltage    | $V_{g2}$     | 100 V        |
| Grid No.1 voltage    | $V_{g1}$     | -8.2 V       |
| Anode current        | $I_a$        | 100 mA       |
| Grid No.2 current    | $I_{g2}$     | 7 mA         |
| Transconductance     | S            | 14 mA/V      |
| Amplification factor | $\mu_{g2g1}$ | 5.6          |
| Internal resistance  | $R_i$        | 5 k $\Omega$ |

**REMARKS**

On pages D to M curves are given for nominal new tubes. On designing a line output circuit it has to be taken into account that due to tube spread and deterioration during life the current may be reduced by 25%.

When the tube is operated below the knee of its  $I_a$ - $V_a$  characteristic the screen grid series resistor must have a minimum value of 2.2 k $\Omega$  to avoid the occurrence of Barkhausen oscillations.

The min. drive at  $V_{ap} = 5$  kV is 100 V  
 and at  $V_{ap} = 7$  kV 120 V

**LIMITING VALUES** (Design centre rating system)

|                               |              |                                   |
|-------------------------------|--------------|-----------------------------------|
| Anode voltage                 | $V_{a0}$     | max. 550 V                        |
|                               | $V_a$        | max. 250 V                        |
| Anode peak voltage            |              |                                   |
| positive                      | $V_{ap}$     | max. 7 kV <sup>1)</sup>           |
| negative                      | $-V_{ap}$    | max. 1.5 kV <sup>1)</sup>         |
| Grid No.2 voltage             | $V_{g20}$    | max. 550 V                        |
|                               | $V_{g2}$     | max. 250 V                        |
| Grid No.1 peak voltage        | $V_{g1p}$    | max. 1 kV <sup>1)</sup>           |
| Anode dissipation             | $W_a$        | } See page 7                      |
| Grid No.2 dissipation         | $W_{g2}$     |                                   |
| Anode + grid No.2 dissipation | $W_a+W_{g2}$ |                                   |
| Cathode current               | $I_k$        | max. 200 mA                       |
| Grid No.1 resistor            | $R_{g1}$     | max. 0.5 M $\Omega$ <sup>2)</sup> |
| Cathode to heater voltage     |              |                                   |
| A. C. value                   | $V_{kf}$     | max. 250 $V_{RMS}$                |
| D. C. value, k pos.           | $V_{kf}$     | max. 250 V                        |
| D. C. value, k neg.           | $V_{kf}$     | max. 200 V                        |

<sup>1)</sup> Valid for application in line output circuits where the max. pulse duration is 22% of a cycle with a max. of 18  $\mu$ s.

<sup>2)</sup>  $R_{g1}$  = max. 2.2 M $\Omega$  for line output application only.

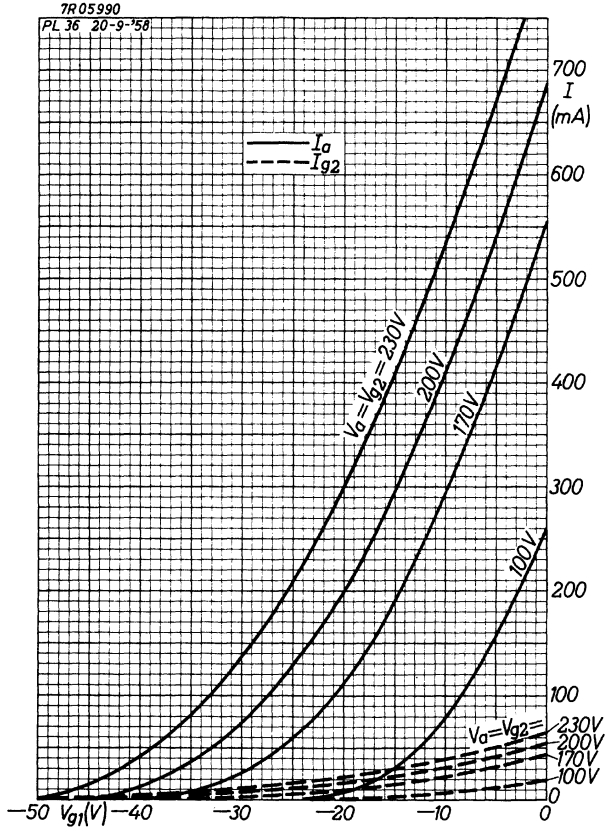



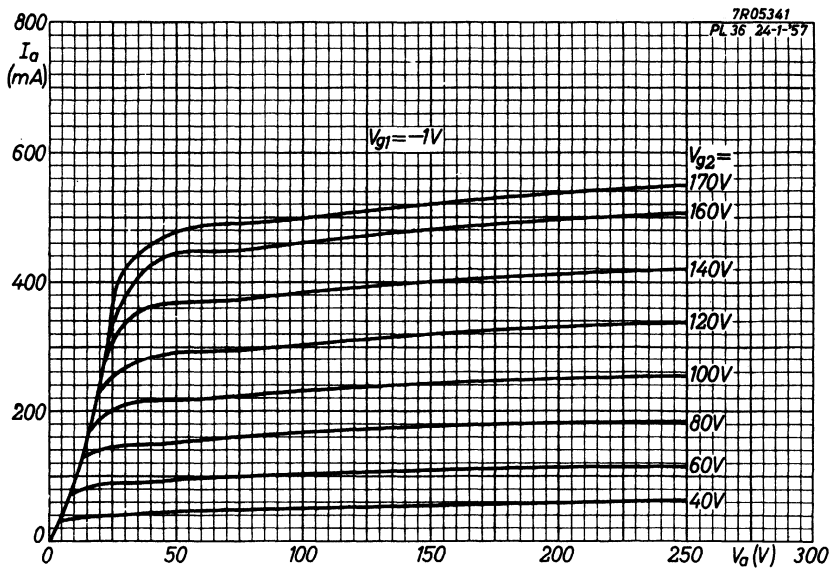
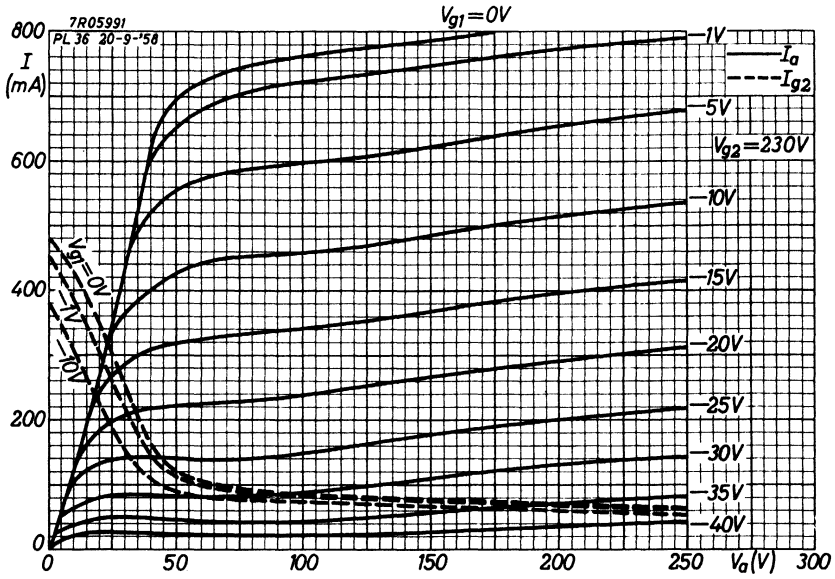

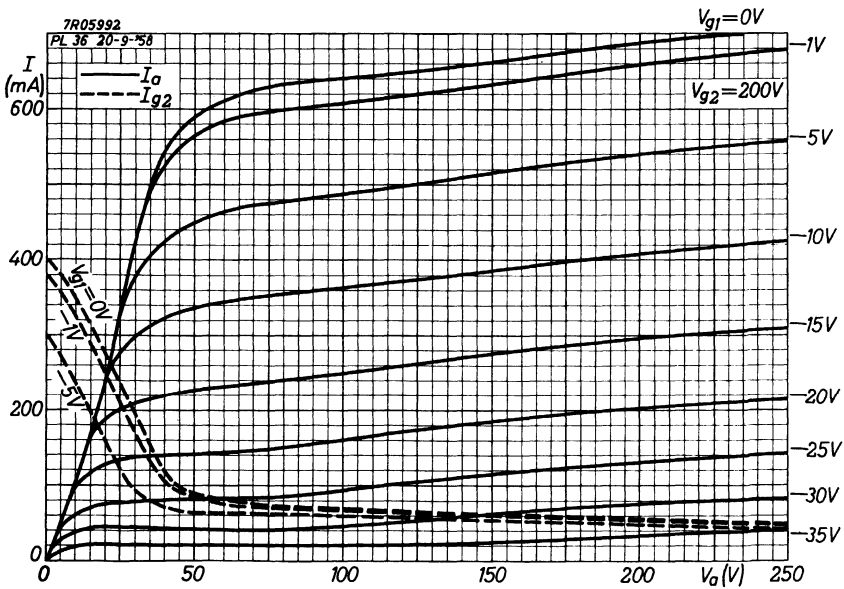
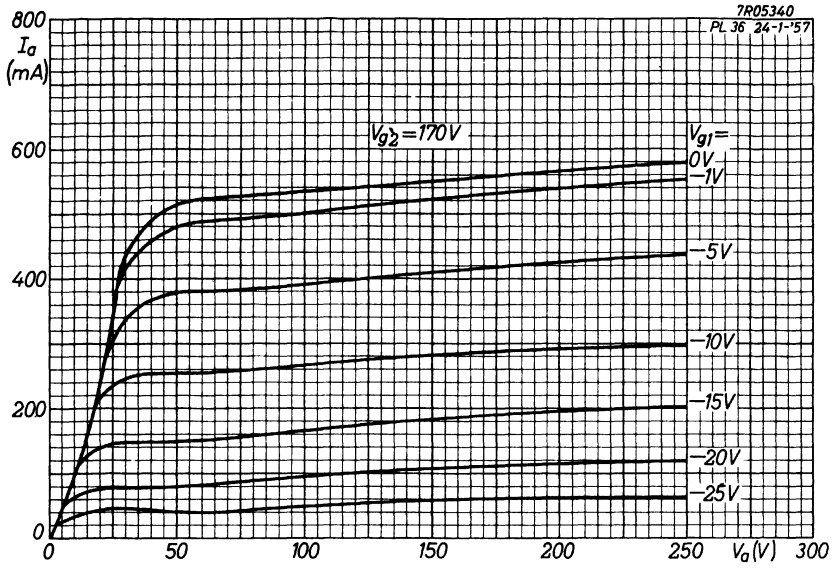

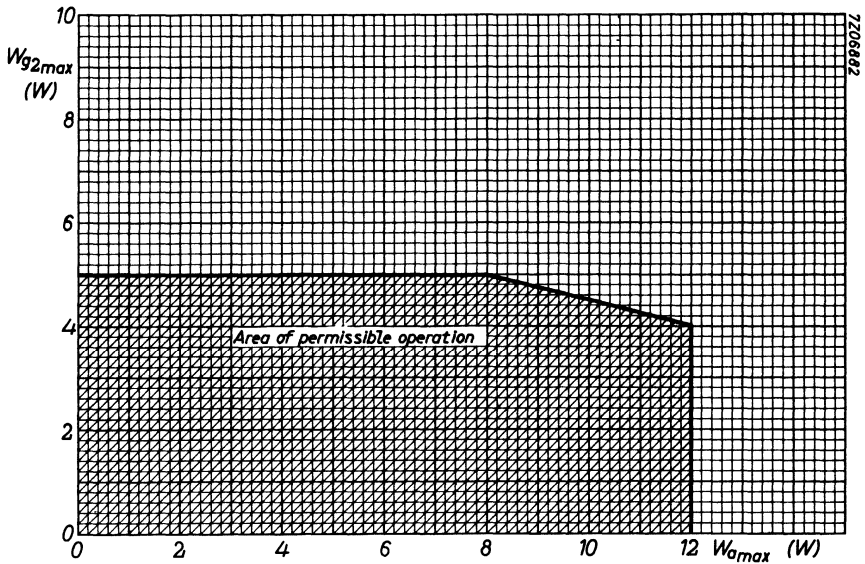
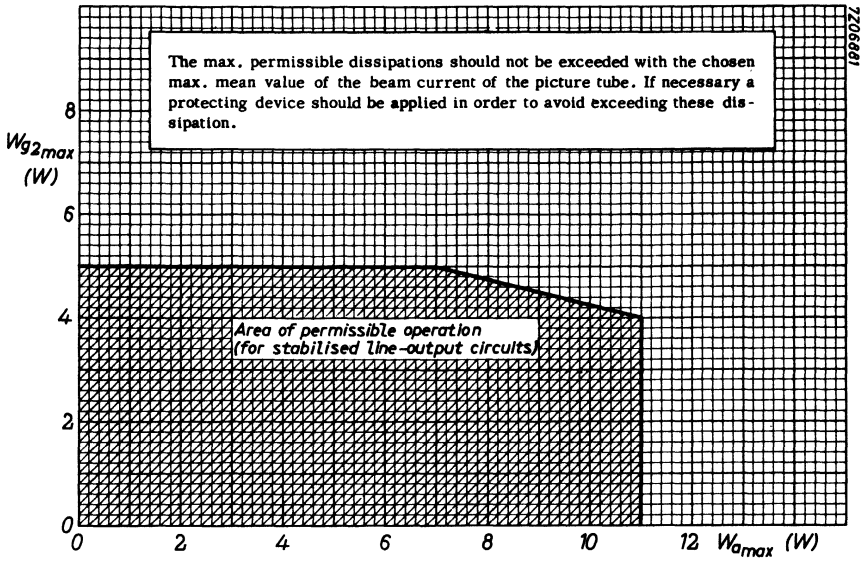



## OUTPUT PENTODE FOR LINE DEFLECTION

Output pentode intended for use as horizontal deflection amplifier in small screen television receivers.

### QUICK REFERENCE DATA

|                    |          |      |     |    |
|--------------------|----------|------|-----|----|
| Anode peak voltage | $V_{ap}$ | max. | 7   | kV |
| Cathode current    | $I_k$    | max. | 180 | mA |

**HEATING** : Indirect by A. C. or D. C. ; series supply

|                |       |      |    |
|----------------|-------|------|----|
| Heater current | $I_f$ | 300  | mA |
| Heater voltage | $V_f$ | 21.5 | V  |

### DIMENSIONS AND CONNECTIONS

Dimensions in mm

Base: Noval

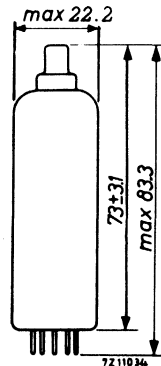
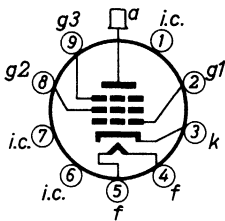

**CAPACITANCES**

|                                |             |             |
|--------------------------------|-------------|-------------|
| Anode to all except grid No. 1 | $C_{a(g1)}$ | 6 pF        |
| Grid No. 1 to all except anode | $C_{g1(a)}$ | 14 pF       |
| Anode to grid No. 1            | $C_{ag1}$   | max. 0.8 pF |
| Anode to cathode               | $C_{ak}$    | max. 0.1 pF |
| Grid No. 1 to heater           | $C_{g1f}$   | max. 0.2 pF |

**TYPICAL CHARACTERISTICS**

A)

|                      |              |               |
|----------------------|--------------|---------------|
| Anode voltage        | $V_a$        | 170 V         |
| Grid No. 3 voltage   | $V_{g3}$     | 0 V           |
| Grid No. 2 voltage   | $V_{g2}$     | 170 V         |
| Grid No. 1 voltage   | $V_{g1}$     | -24 V         |
| Anode current        | $I_a$        | 45 mA         |
| Grid No. 2 current   | $I_{g2}$     | 2.4 mA        |
| Transconductance     | $S$          | 6.3 mA/V      |
| Internal resistance  | $R_i$        | 11 k $\Omega$ |
| Amplification factor | $\mu_{g2g1}$ | 5.0           |

**TYPICAL CHARACTERISTICS** (continued)

B) (Measured under pulse conditions)

|                            |           |                |
|----------------------------|-----------|----------------|
| Anode voltage              | $V_a$     | 40 V           |
| Grid No. 3 voltage         | $V_{g3}$  | 0 V            |
| Grid No. 2 supply voltage  | $V_{bg2}$ | 190 V          |
| Grid No. 2 series resistor | $R_{g2}$  | 4.7 k $\Omega$ |
| Grid No. 1 voltage         | $V_{g1}$  | 0 V            |
| Anode current              | $I_a$     | 180 mA         |
| Grid No. 2 current         | $I_{g2}$  | 18 mA          |

**OPERATING CONDITIONS**

Stabilized circuits (D.C. feedback)

Cut-off voltage

The minimum required cut-off voltage ( $-V_{g1}$ ) during flyback is 120 V at  $V_a = 6000$  V,  $V_{g2} = 190$  V and  $Z_{g1} = 1$  k $\Omega$  at line frequency.

Supply voltage: See page 5

Minimum required values of the screengrid voltage and of the anode voltage, when the tube is used in a line output stage.

The graphs refer to nominal mains voltage provided the specified values of  $I_a$  at  $V_a$  min, will be available throughout life of the tube at supply voltage values 10% below nominal.

In order to prevent Barkhausen interferences and less of stabilisation, care should be taken that the anode voltage never drops below the specified  $V_a$  min during the scanning period.

**LIMITING VALUES** (Design centre rating system)

|                                |                        |                         |
|--------------------------------|------------------------|-------------------------|
| Anode voltage                  | $V_{a0}$               | max. 550 V              |
|                                | $V_a$                  | max. 250 V              |
| Anode voltage, peak            | $V_{ap}$               | max. 7 kV <sup>1)</sup> |
| negative peak                  | $-V_{ap}$              | max. 7 kV <sup>1)</sup> |
| Anode dissipation              | $W_a$                  | } see figure below      |
| Grid No. 2 dissipation         | $W_{g2}$ <sup>2)</sup> |                         |
| Anode + grid No. 2 dissipation | $W_a + W_{g2}$         |                         |
| Grid No. 2 voltage             | $V_{g20}$              | max. 550 V              |
|                                | $V_{g2}$               | max. 250 V              |
| Cathode current                | $I_k$                  | max. 180 mA             |
| Cathode to heater voltage      | $V_{kf}$               | max. 200 V              |
| Grid No. 1 resistor            | $R_{g1}$               | max. 0.5 M $\Omega$     |

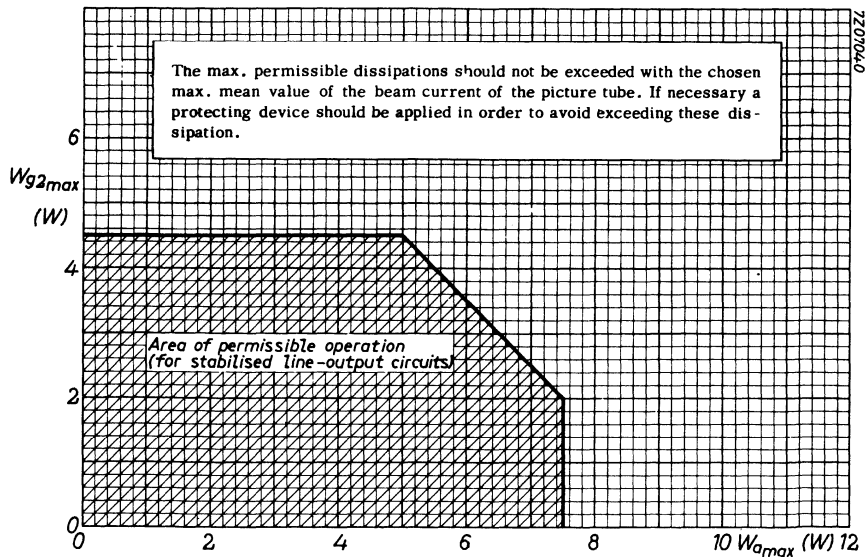

1) Maximum pulse duration 22% of a cycle but maximum 18  $\mu$ s.

2) During the heating-up of the cathode  $W_{g2} = \text{max. } 6 \text{ W}$ .



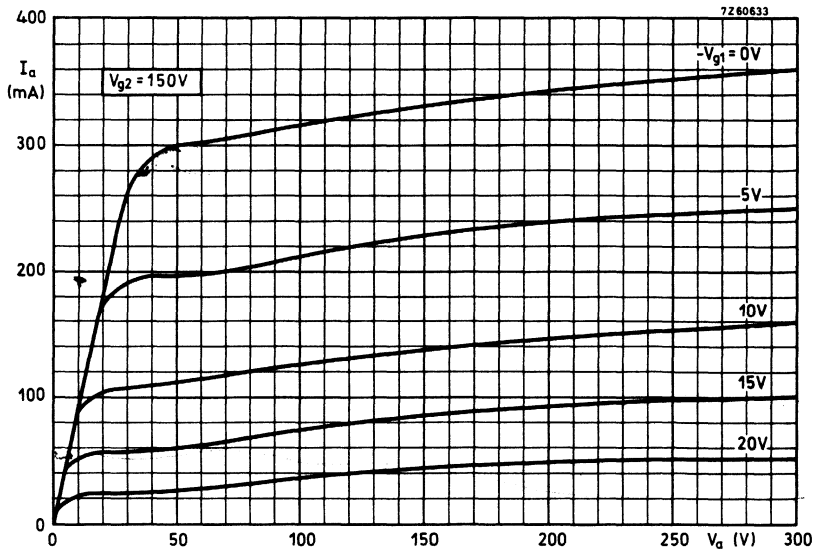
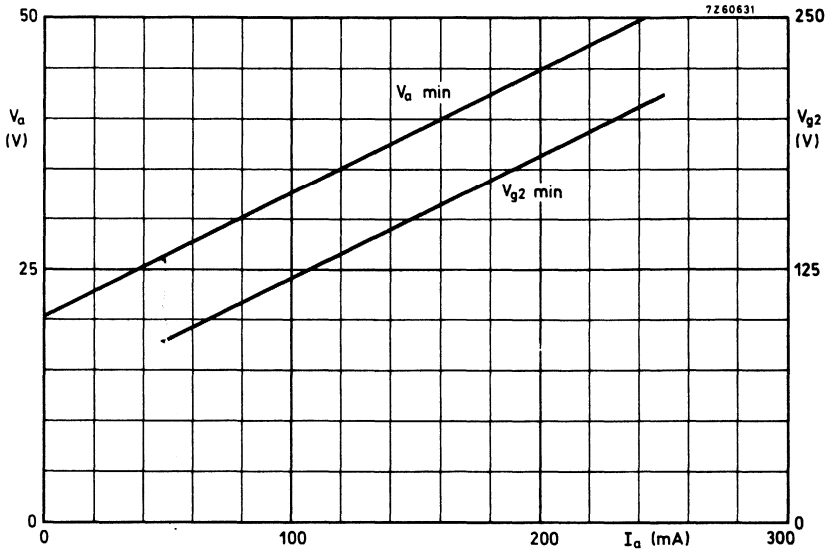

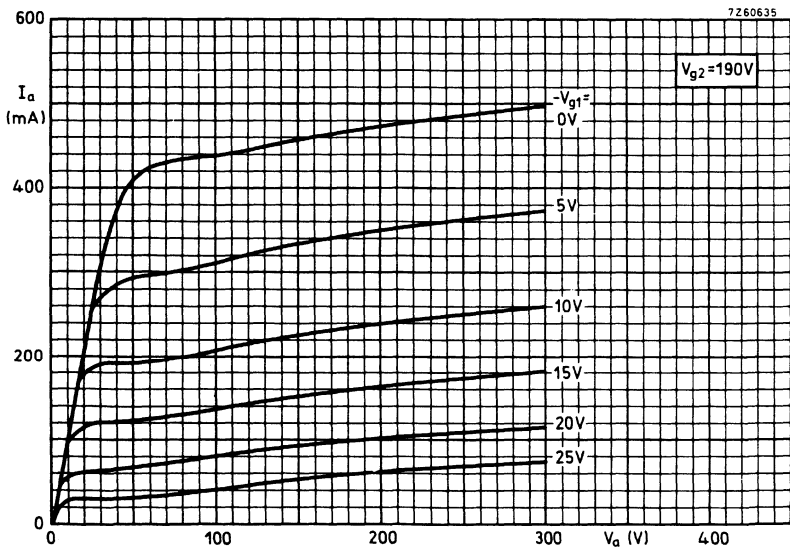
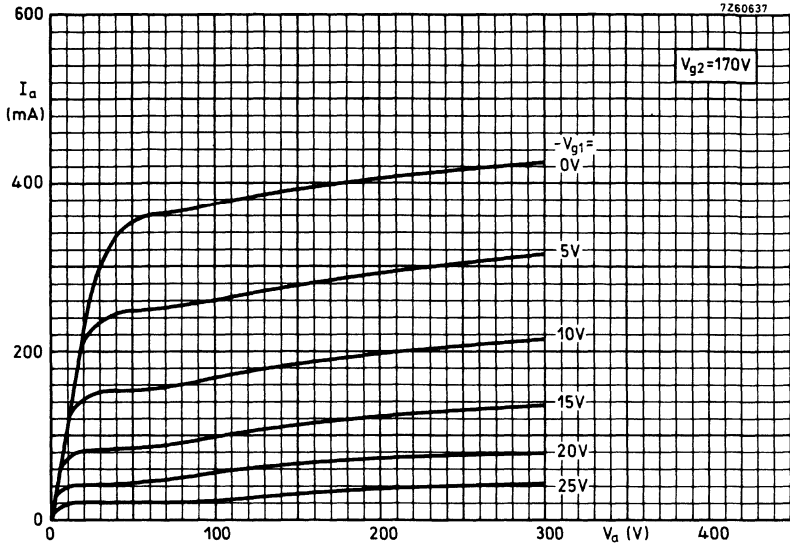

## VIDEO OUTPUT PENTODE

Pentode intended for use as video output tube.

| QUICK REFERENCE DATA |                |           |
|----------------------|----------------|-----------|
| Anode current        | $I_a$          | 36 mA     |
| Transconductance     | $S$            | 10.5 mA/V |
| Amplification factor | $\mu_{g_2g_1}$ | 24 -      |

**HEATING:** Indirect by A.C. or D.C.; series supply

|                |       |        |
|----------------|-------|--------|
| Heater current | $I_f$ | 300 mA |
| Heater voltage | $V_f$ | 15 V   |

### DIMENSIONS AND CONNECTIONS

Dimensions in mm

Base: Noval

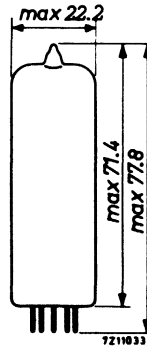
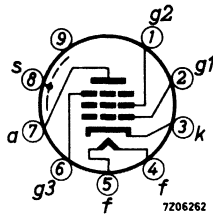

### CAPACITANCES

|                               |              |              |
|-------------------------------|--------------|--------------|
| Anode to all except grid No.1 | $C_{a(g_1)}$ | 6.6 pF       |
| Grid No.1 to all except anode | $C_{g_1(a)}$ | 10.8 pF      |
| Anode to grid No.1            | $C_{ag_1}$   | max. 0.1 pF  |
| Grid No.1 to grid No.2        | $C_{g_1g_2}$ | 3.2 pF       |
| Grid No.1 to heater           | $C_{g_1f}$   | max. 0.15 pF |

**TYPICAL CHARACTERISTICS**

|                      |              |      |      |            |
|----------------------|--------------|------|------|------------|
| Anode voltage        | $V_a$        | 170  | 200  | V          |
| Grid No.3 voltage    | $V_{g3}$     | 0    | 0    | V          |
| Grid No.2 voltage    | $V_{g2}$     | 170  | 200  | V          |
| Grid No.1 voltage    | $V_{g1}$     | -2.3 | -3.5 | V          |
| Anode current        | $I_a$        | 36   | 36   | mA         |
| Grid No.2 current    | $I_{g2}$     | 5.0  | 5.0  | mA         |
| Transconductance     | S            | 10.5 | 10.5 | mA/V       |
| Amplification factor | $\mu_{g2g1}$ | 24   | 24   | -          |
| Internal resistance  | $R_i$        | 0.1  | 0.1  | M $\Omega$ |

**LIMITING VALUES** (Design centre rating system)

|                           |           |      |     |                 |
|---------------------------|-----------|------|-----|-----------------|
| Anode voltage             | $V_{a0}$  | max. | 550 | V               |
|                           | $V_a$     | max. | 250 | V               |
| Grid No.2 voltage         | $V_{g20}$ | max. | 550 | V               |
|                           | $V_{g2}$  | max. | 250 | V               |
| Anode dissipation         | $W_a$     | max. | 9   | W               |
| Grid No.2 dissipation     | $W_{g2}$  | max. | 2   | W               |
| Cathode current           | $I_k$     | max. | 70  | mA              |
| Grid No.1 resistor        |           |      |     |                 |
| for fixed bias            | $R_{g1}$  | max. | 0.5 | M $\Omega$      |
| for automatic bias        | $R_{g1}$  | max. | 1   | M $\Omega$      |
| Cathode to heater voltage | $V_{kf}$  | max. | 200 | V <sup>1)</sup> |

1) D.C. component max. 150 V

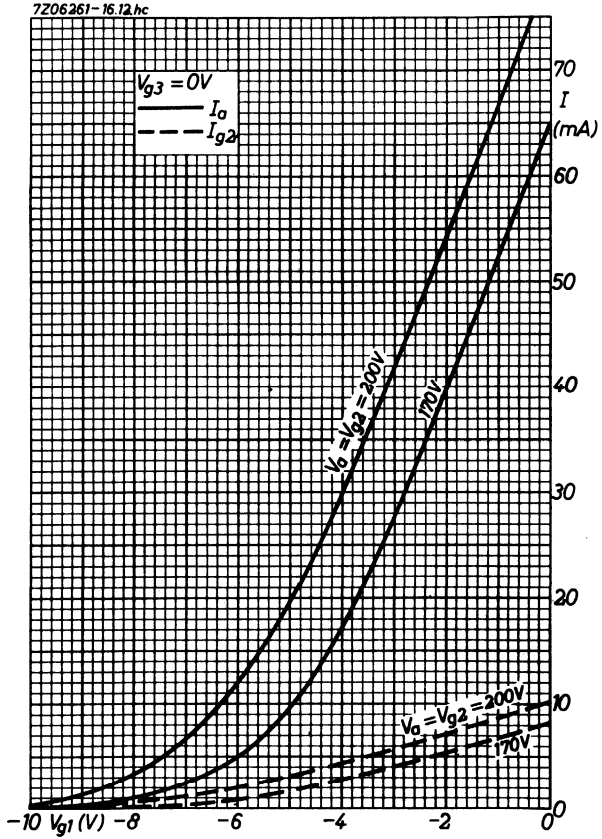

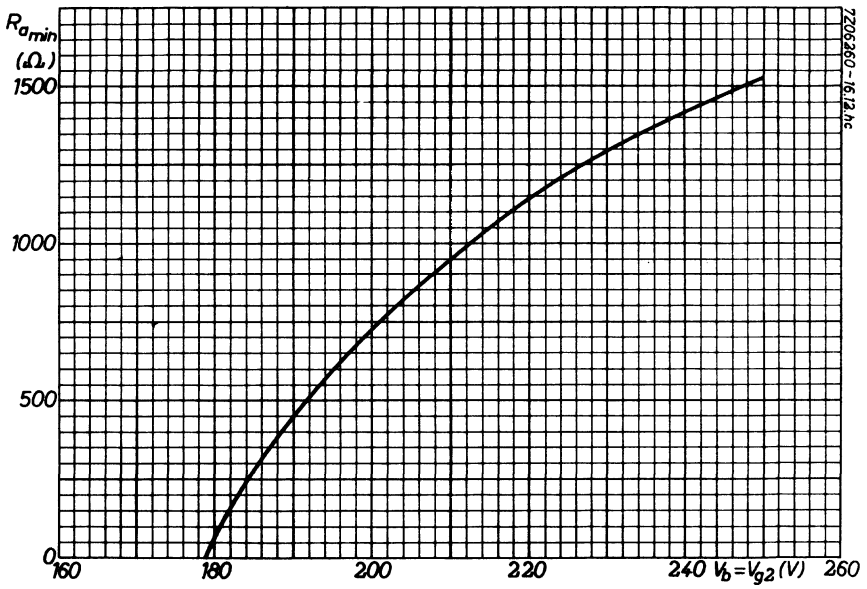

7205260-16121c

## FRAME AND A.F. OUTPUT PENTODE

Pentode intended for use as frame output tube in television receivers and as A.F. power amplifier.

| QUICK REFERENCE DATA |          |      |        |
|----------------------|----------|------|--------|
| Anode peak voltage   | $V_{ap}$ | max. | 2 kV   |
| Cathode current      | $I_k$    | max. | 100 mA |
| Output power         | $W_o$    |      | 5.3 W  |

**HEATING:** Indirect by A.C. or D.C.; series supply

|                |       |        |
|----------------|-------|--------|
| Heater current | $I_f$ | 300 mA |
| Heater voltage | $V_f$ | 15 V   |

### DIMENSIONS AND CONNECTIONS

Base: Noval

Dimensions in mm

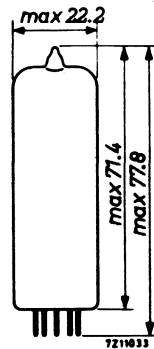
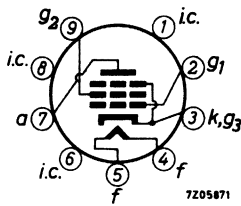

### CAPACITANCES

|                                |              |              |
|--------------------------------|--------------|--------------|
| Anode to all except grid No. 1 | $C_{a(g_1)}$ | 6.8 pF       |
| Grid No. 1 to all except anode | $C_{g_1(a)}$ | 13 pF        |
| Anode to grid No. 1            | $C_{ag_1}$   | max. 0.6 pF  |
| Grid No. 1 to heater           | $C_{g_1f}$   | max. 0.25 pF |

**OPTIMUM PEAK ANODE CURRENT IN FRAME OUTPUT APPLICATION**

The circuit should be designed so that the peak anode current does not exceed:

- 145 mA at  $V_a = 60$  V,  $V_{g2} = 170$  V,  $I_f = 300$  mA
- 190 mA at  $V_a = 70$  V,  $V_{g2} = 200$  V,  $I_f = 300$  mA
- 220 mA at  $V_a = 80$  V,  $V_{g2} = 220$  V,  $I_f = 300$  mA

The minimum available value of the peak anode current at end of life and  $I_f = 285$  mA is:

- 125 mA at  $V_a = 60$  V,  $V_{g2} = 170$  V
- 160 mA at  $V_a = 70$  V,  $V_{g2} = 200$  V
- 185 mA at  $V_a = 80$  V,  $V_{g2} = 220$  V

**OPERATING CHARACTERISTICS**

A.F. power amplifier, class A (measured with  $V_k$  constant)

|  |             |            |            |                             |
|--|-------------|------------|------------|-----------------------------|
| Supply voltage                               | $V_b$       | 170        | 200        | V                           |
| Grid No.2 series resistor<br>(non decoupled) | $R_{g2}$    | 0          | 470        | $\Omega$                    |
| Cathode resistor                             | $R_k$       | 130        | 215        | $\Omega$                    |
| Load resistance                              | $R_{a\sim}$ | 2          | 2.5        | k $\Omega$                  |
| Grid No.1 driving voltage                    | $V_i$       | 0 0.47 6.1 |            | 0 0.52 7.0 V <sub>RMS</sub> |
| Anode current                                | $I_a$       | 75 - 76    | 65 - 64    | mA                          |
| Grid No.2 current                            | $I_{g2}$    | 4.0 - 16.5 | 3.2 - 11.4 | mA                          |
| Output power                                 | $W_o$       | 0 0.05 5.1 | 0 0.05 5.3 | W                           |
| Distortion                                   | $d_{tot}$   | - - 10     | - - 10     | %                           |
| Anode supply voltage                         | $V_{ba}$    |            | 230        | V                           |
| Grid No.2 supply voltage                     | $V_{bg2}$   |            | 200        | V                           |
| Grid No.2 series resistor<br>(non decoupled) | $R_{g2}$    |            | 220        | $\Omega$                    |
| Cathode resistor                             | $R_k$       |            | 270        | $\Omega$                    |
| Load resistance                              | $R_{a\sim}$ |            | 3.25       | k $\Omega$                  |
| Grid No.1 driving voltage                    | $V_i$       | 0 0.42 5.7 |            | V <sub>RMS</sub>            |
| Anode current                                | $I_a$       |            | 56 - 54    | mA                          |
| Grid No.2 current                            | $I_{g2}$    |            | 2.2 - 9.7  | mA                          |
| Output power                                 | $W_o$       |            | 0 0.05 5.4 | W                           |
| Distortion                                   | $d_{tot}$   |            | - 10       | %                           |



**OPERATING CHARACTERISTICS**

A.F. power amplifier, class AB, two tubes in push-pull

|                           |              |                             |                            |           |
|---------------------------|--------------|-----------------------------|----------------------------|-----------|
| Anode supply voltage      | $V_{ba}$     | 200                         | 230                        | V         |
| Grid No.2 voltage         | $V_{bg2}$    | 200                         | 200                        | V         |
| Common cathode resistor   | $R_k$        | 120                         | 130                        | $\Omega$  |
| Load resistance           | $R_{aa\sim}$ | 3                           | 4                          | $k\Omega$ |
| Grid No.1 driving voltage | $V_i$        | $\overbrace{0\ 0.47\ 14.3}$ | $\overbrace{0\ 0.4\ 14.6}$ | $V_{RMS}$ |
| Anode current             | $I_a$        | $2x60 - 2x64.5$             | $2x56 - 2x61$              | mA        |
| Grid No.2 current         | $I_{g2}$     | $2x3.0 - 2x18.5$            | $2x2.3 - 2x17.5$           | mA        |
| Output power              | $W_o$        | $0\ 0.05\ 14.3$             | $0\ 0.05\ 17.5$            | W         |
| Distortion                | $d_{tot}$    | - - 3.8                     | - - 5.4                    | %         |

**LIMITING VALUES** (Design centre rating system)

|                                      |           |      |                    |
|--------------------------------------|-----------|------|--------------------|
| Anode voltage                        | $V_{a0}$  | max. | 550 V              |
|                                      | $V_a$     | max. | 250 V              |
| Anode peak voltage                   | $V_{ap}$  | max. | 2 kV <sup>1)</sup> |
| Grid No.2 voltage                    | $V_{g2o}$ | max. | 550 V              |
|                                      | $V_{g2}$  | max. | 250 V              |
| Anode dissipation                    | $W_a$     | max. | 12 W <sup>2)</sup> |
| Grid No.2 dissipation                |           |      |                    |
| average                              | $W_{g2}$  | max. | 1.75 W             |
| peak                                 | $W_{g2p}$ | max. | 6 W                |
| Cathode current                      | $I_k$     | max. | 100 mA             |
| Grid No.1 resistor                   |           |      |                    |
| for automatic bias                   | $R_{g1}$  | max. | 1 $M\Omega$        |
| for frame output with automatic bias | $R_{g1}$  | max. | 2 $M\Omega$        |
| Cathode to heater voltage            | $V_{kf}$  | max. | 200 V              |

<sup>1)</sup> In frame output circuits where the max. pulse duration is 4% of a cycle with a max. of 0.8 ms.

<sup>2)</sup> For frame output application  $W_a = \text{max. } 10 \text{ W}$ .

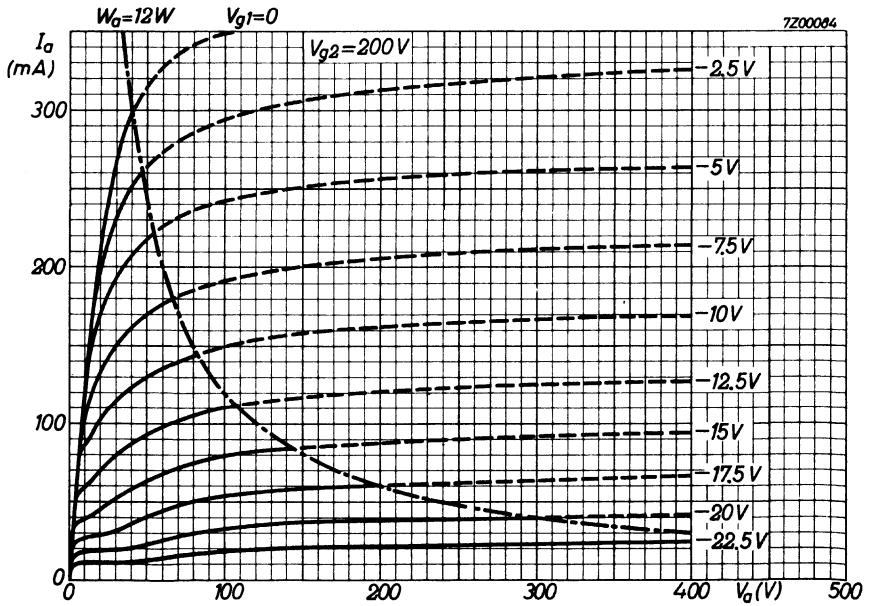
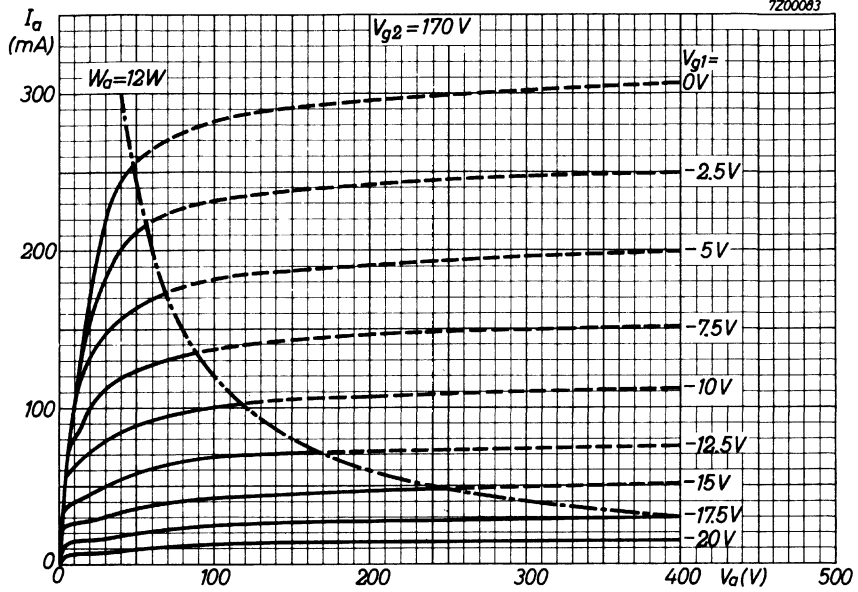

## A.F. OUTPUT PENTODE

Pentode intended for use as A.F. power amplifier.

| QUICK REFERENCE DATA |              |          |
|----------------------|--------------|----------|
| Anode current        | $I_a$        | 24 mA    |
| Transconductance     | $S$          | 5.4 mA/V |
| Amplification factor | $\mu_{g2g1}$ | 17       |
| Output power         | $W_o$        | 3 W      |

**HEATING:** Indirect by A.C. or D.C.; series supply

Heater current

$I_f$  300 mA

Heater voltage

$V_f$  4.5 V

### DIMENSIONS AND CONNECTIONS

Dimensions in mm

Base: miniature 7-pin

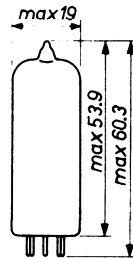
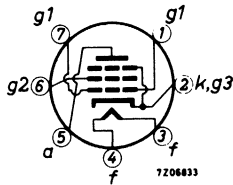

### CAPACITANCES

Anode to all except grid No. 1

$C_a(g_1)$  3.5 pF

Grid No. 1 to all except anode

$C_{g1(a)}$  5.3 pF

Anode to grid No. 1

$C_{ag1}$  max. 0.4 pF

Grid No. 1 to heater

$C_{g1f}$  max. 0.2 pF

**TYPICAL CHARACTERISTICS**

|                      |              |               |
|----------------------|--------------|---------------|
| Anode voltage        | $V_a$        | 250 V         |
| Grid No.2 voltage    | $V_{g2}$     | 250 V         |
| Grid No.1 voltage    | $V_{g1}$     | -9.0 V        |
| Anode current        | $I_a$        | 24 mA         |
| Grid No.2 current    | $I_{g2}$     | 4.5 mA        |
| Transconductance     | S            | 5.4 mA/V      |
| Amplification factor | $\mu_{g2g1}$ | 17            |
| Internal resistance  | $R_i$        | 70 k $\Omega$ |

**OPERATING CHARACTERISTICS**

Class A

|  |            |      |                       |
|--|------------|------|-----------------------|
| Anode voltage                                  | $V_a$      | 200  | 250 V                 |
| Grid No.2 voltage                              | $V_{g2}$   | 200  | 250 V                 |
| Cathode resistor                               | $R_k$      | 230  | 320 $\Omega$          |
| Anode current ( $V_i = 0$ )                    | $I_a$      | 23   | 24 mA                 |
| Grid No.2 current ( $V_i = 0$ )                | $I_{g2}$   | 4.2  | 4.5 mA                |
| Load resistance                                | $R_a \sim$ | 8    | 10 k $\Omega$         |
| Grid No.1 driving voltage                      | $V_i$      | 4.5  | 5 V <sub>RMS</sub>    |
| Output power                                   | $W_o$      | 2.3  | 3.0 W                 |
| Distortion                                     | $d_{tot}$  | 10   | 10 %                  |
| Grid No.1 driving voltage<br>for $W_o = 50$ mW | $V_i$      | 0.50 | 0.50 V <sub>RMS</sub> |

**LIMITING VALUES** (Design centre rating system)

|                                     |            |      |                |
|-------------------------------------|------------|------|----------------|
| Anode voltage                       | $V_{a0}$   | max. | 550 V          |
|                                     | $V_a$      | max. | 300 V          |
| Grid No. 2 voltage                  | $V_{g2_0}$ | max. | 550 V          |
|                                     | $V_{g2}$   | max. | 300 V          |
| Anode dissipation                   | $W_a$      | max. | 6 W            |
| Grid No. 2 dissipation              |            |      |                |
| average at $V_i = 0$                | $W_{g2}$   | max. | 1.25 W         |
| peak                                | $W_{g2_p}$ | max. | 2.5 W          |
| Cathode current                     | $I_k$      | max. | 35 mA          |
| Grid No. 1 resistor, automatic bias | $R_{g1}$   | max. | 2.2 M $\Omega$ |
| Cathode to heater voltage           | $V_{kf}$   | max. | 200 V          |

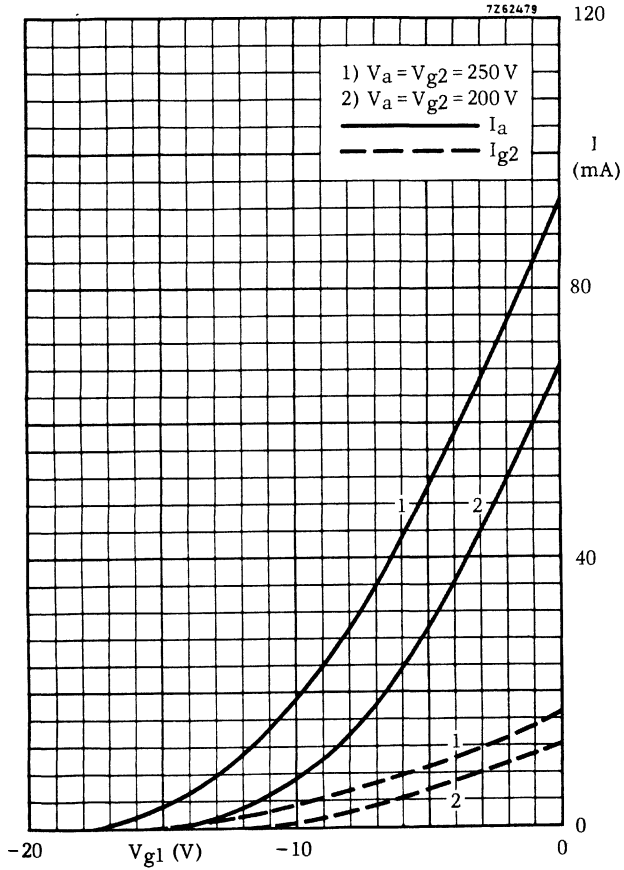

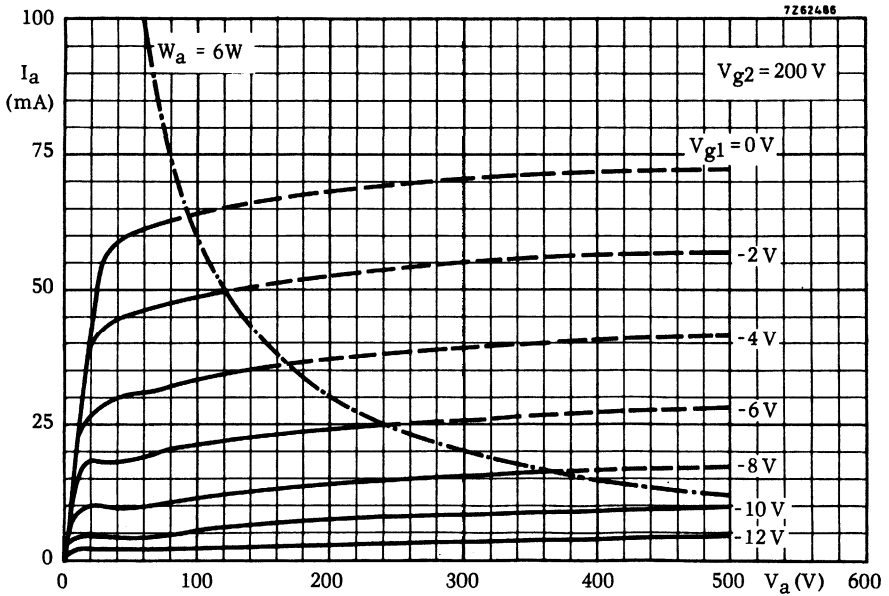
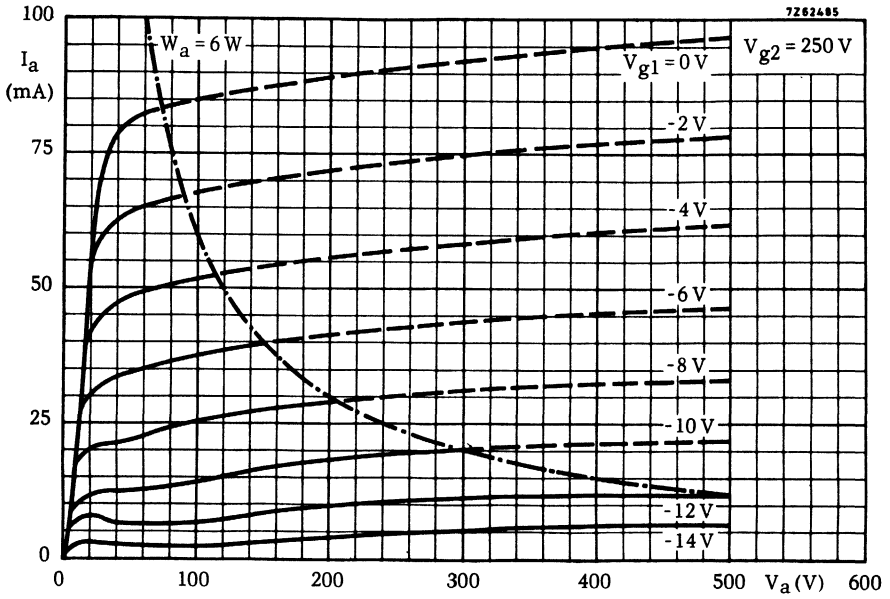

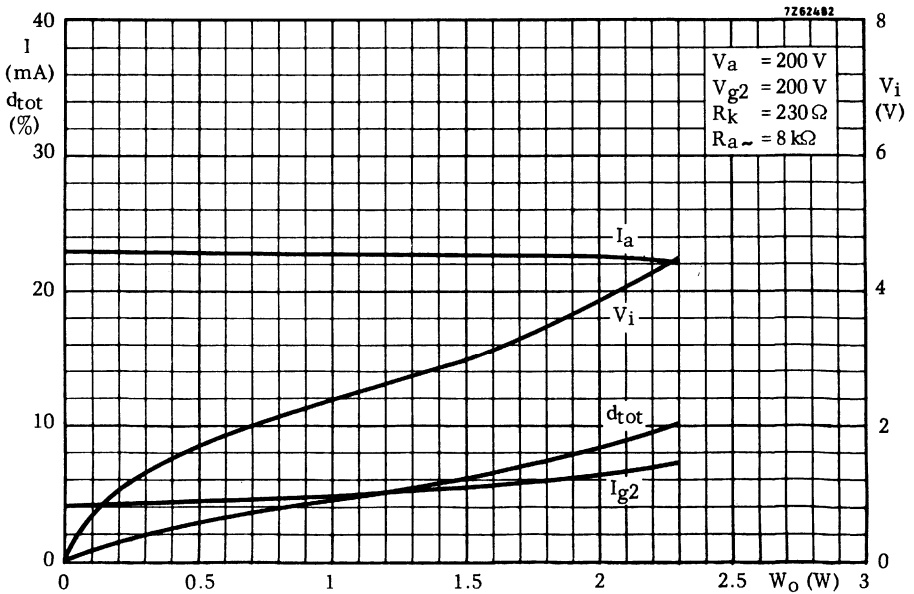
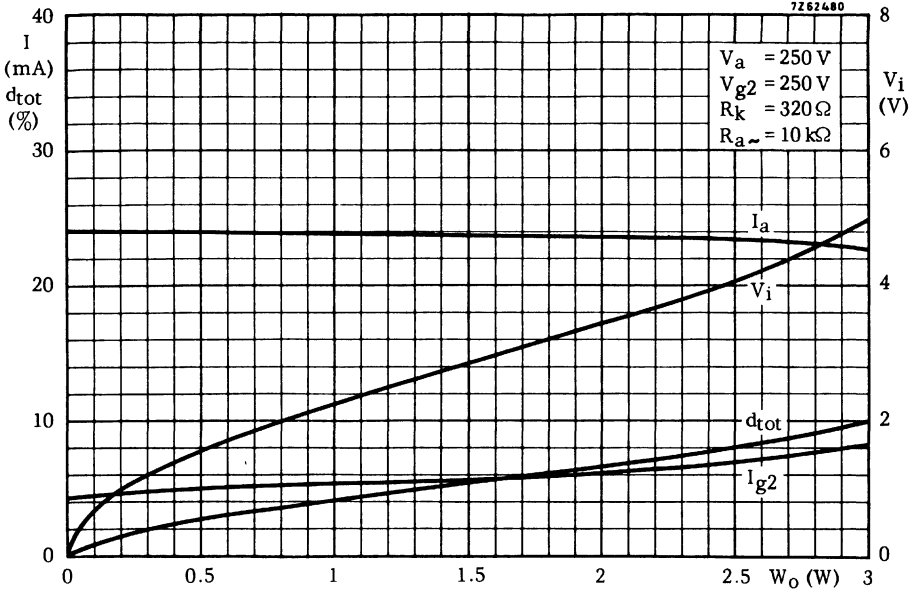



## LINE OUTPUT PENTODE

Beam pentode intended for use as line output tube in television receivers.

| QUICK REFERENCE DATA |          |      |        |
|----------------------|----------|------|--------|
| Anode peak voltage   | $V_{ap}$ | max. | 7 kV   |
| Cathode current      | $I_k$    | max. | 250 mA |
| Anode dissipation    | $W_a$    | max. | 12 W   |

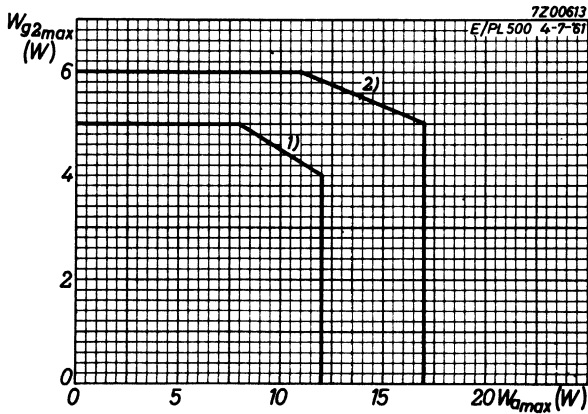

- 1) Design centre limits for  $W_a$  and  $W_{g2}$ .
- 2) These limits for  $W_a$  and  $W_{g2}$  should not be exceeded with a nominal tube operating in a normal line deflection circuit under the worst probable conditions.

-----  
 For further data and curves of this type  
 please refer to PL504  
 -----



## LINE OUTPUT PENTODE

Beam pentode intended for use as line output tube in television receivers.

| QUICK REFERENCE DATA |          |      |        |
|----------------------|----------|------|--------|
| Anode peak voltage   | $V_{ap}$ | max. | 7 kV   |
| Cathode current      | $I_k$    | max. | 250 mA |
| Anode dissipation    | $W_a$    | max. | 16 W   |

**HEATING:** Indirect by A. C. or D. C.; series supply

Heater current

$I_f$  300 mA

Heater voltage

$V_f$  27 V

### DIMENSIONS AND CONNECTIONS

Dimensions in mm

Base: Magnoval; IEC 67-I-36a

Cap : Type 1

Outline: IEC67-II-15, type 6

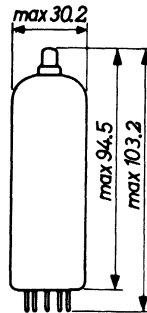
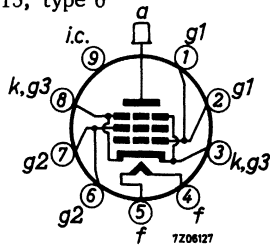

### CAPACITANCES

Anode to grid No. 1

$C_{ag1}$  1.75 pF

Grid No. 1 to heater

$C_{g1f}$  max. 0.2 pF

**TYPICAL DYNAMIC CHARACTERISTICS** (measured under pulse conditions)

|                   |          |     |      |    |
|-------------------|----------|-----|------|----|
| Anode voltage     | $V_a$    | 50  | 7000 | V  |
| Grid No.2 voltage | $V_{g2}$ | 200 | 200  | V  |
| Grid No.1 voltage | $V_{g1}$ | -10 | -120 | V  |
| Anode current     | $I_a$    | 420 | 0.05 | mA |
| Grid No.2 current | $I_{g2}$ | 37  |      | mA |

**OPERATING CHARACTERISTICS**

Stabilized circuits (D.C. feedback)

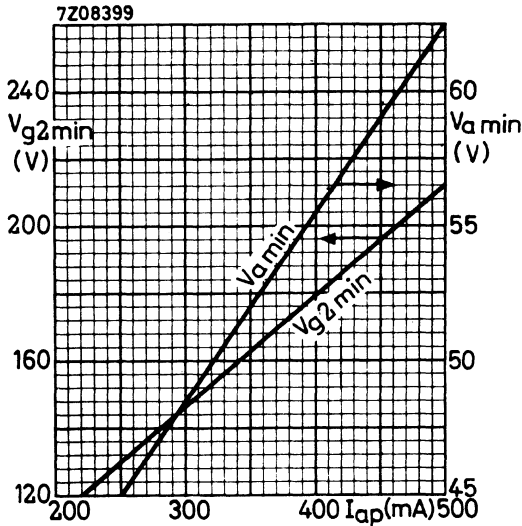

Minimum required values of the screen grid voltage and of the anode voltage when the tube is used in line output stages. The graphs refer to nominal mains voltage provided the specified values of  $V_a$  are increased by 10% of the anode supply voltage. The specified values of  $I_{ap}$  will be available throughout life of the tube at supply voltage values 10% below nominal.

In order to prevent Barkhausen interferences, care should be taken that the anode voltage never drops below the specified  $V_a \min.$  during the scanning period.

Non stabilized circuits

|                           |          |     |     |                  |
|---------------------------|----------|-----|-----|------------------|
| Supply voltage            | $V_b$    | 190 | 230 | V                |
| Grid No.2 series resistor | $R_{g2}$ | 2.2 | 2.2 | k $\Omega$       |
| Grid No.1 voltage         | $V_{g1}$ | +1  | +1  | V                |
| Anode peak current        | $I_{ap}$ | 230 | 320 | mA <sup>1)</sup> |

<sup>1)</sup> See page 3

**HUM**

At  $Z_{g1} = 200 \text{ k}\Omega$  ( $f = 50 \text{ Hz}$ ),  $V_{kf} = 220 \text{ V}_{\text{RMS}}$  and without wiring and socket capacitances, the equivalent grid hum voltage is  $< 5 \text{ mV}$ .

**LIMITING VALUES** (Design centre rating system unless otherwise stated)

|                           |                   |            |                           |
|---------------------------|-------------------|------------|---------------------------|
| Anode voltage             | $V_{a0}$          | max.       | 550 V                     |
| Anode voltage             | $V_a$             | max.       | 250 V                     |
| Anode voltage, peak       | $V_{ap}$          | max.       | 7000 V 3)4)               |
| Grid No.2 voltage         | $V_{g20}$         | max.       | 550 V                     |
| Grid No.2 voltage         | $V_{g2}$          | max.       | 250 V                     |
| Anode dissipation         | $W_a$             | see page 4 |                           |
| Grid No.2 dissipation     | $W_{g2}$          | see page 4 | 2)                        |
| Cathode current           | $I_k$             | max.       | 250 mA                    |
| Grid No.1 resistor        | $R_{g1}$          | max.       | 0.5 $\text{M}\Omega$ 5)   |
| Cathode to heater voltage | $V_{kf}$          | max.       | 250 V                     |
| Bulb temperature          | $t_{\text{bulb}}$ | max.       | 280 $^{\circ}\text{C}$ 6) |

**NOTES**

- To allow for tube spread, deterioration during life and a mains voltage 10 % below nominal, the specified values for  $I_{ap}$  should not be exceeded at nominal mains voltage and at the specified conditions.
- To prevent an excessive value of  $W_{g2}$  during the heating-up period, the minimum  $R_{g2}$  values are given in the graph below.

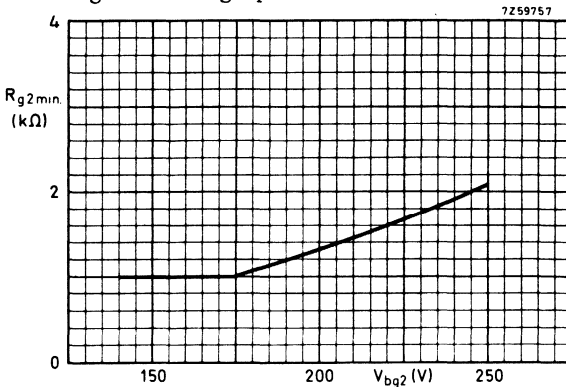

- Maximum pulse duration is 22 % of a cycle and max. 18  $\mu\text{s}$ .
- $V_{ap}$  design max. 8 kV
- $R_{g1} = \text{max. } 2.2 \text{ M}\Omega$  for line output application.
- Absolute max. value.

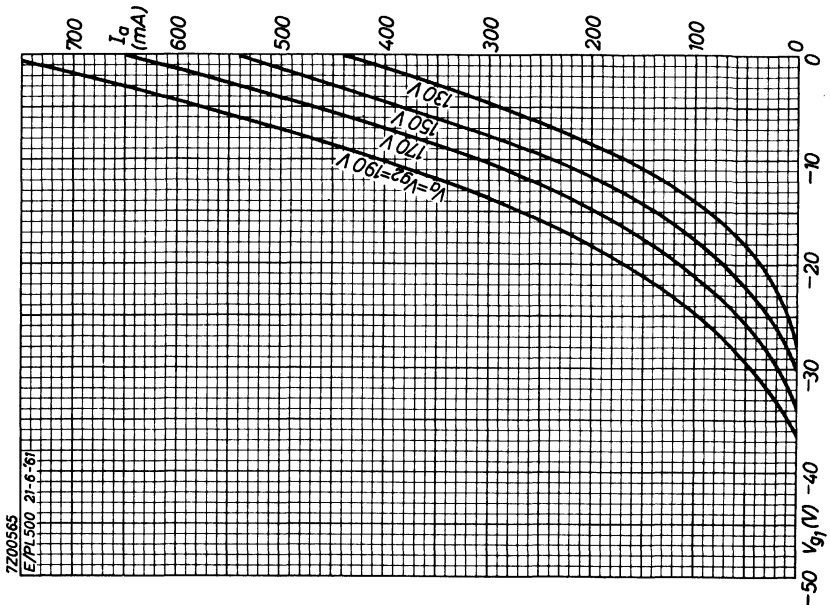
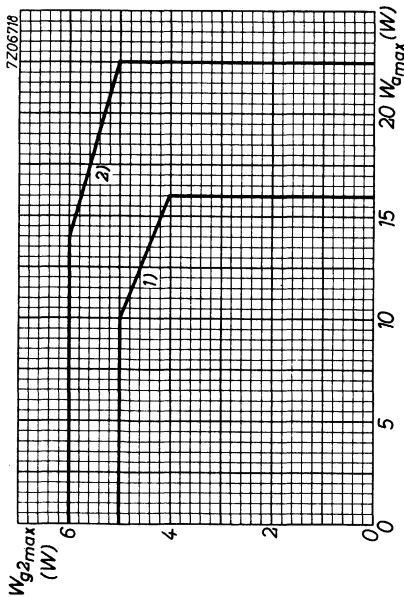

- 1) Design centre limits for  $W_a$  and  $W_{g2}$ .
- 2) These limits for  $W_a$  and  $W_{g2}$  should not be exceeded with a nominal tube operating in a normal line deflection circuit under the worst probable conditions.

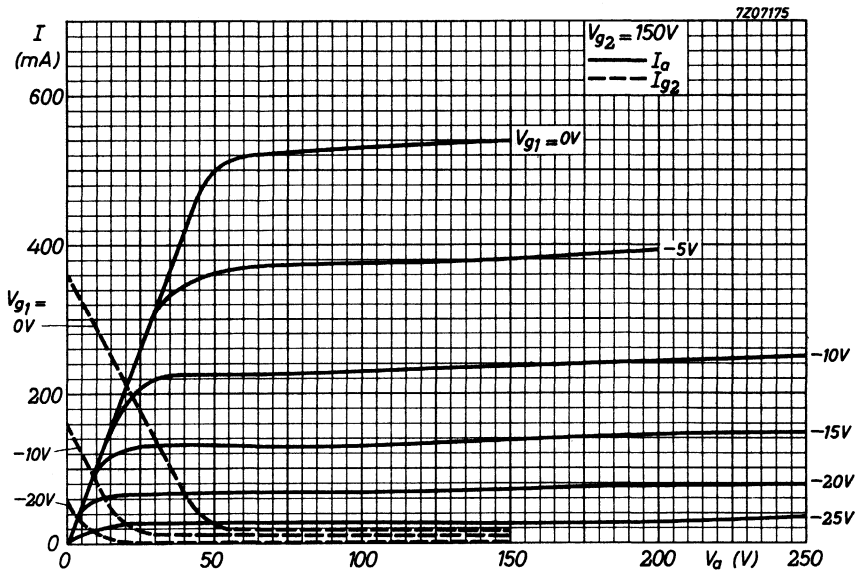
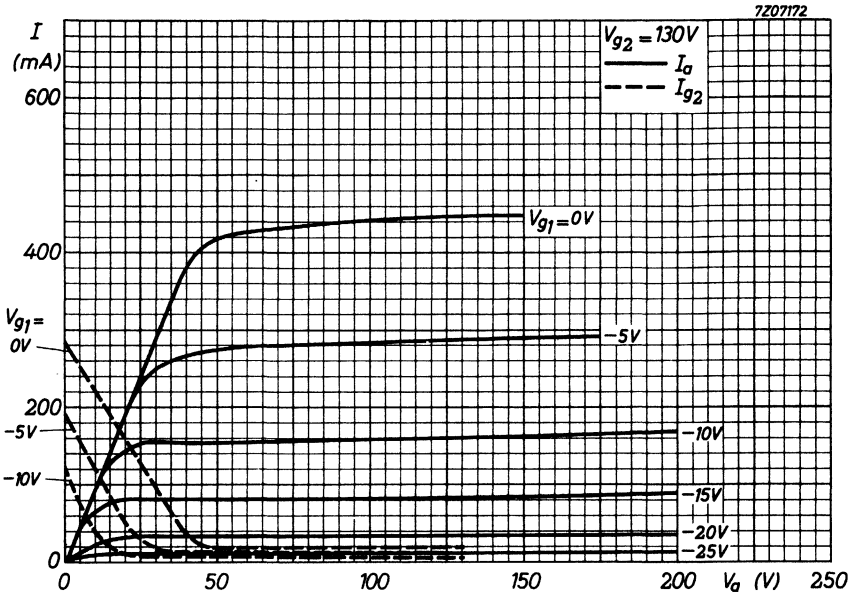

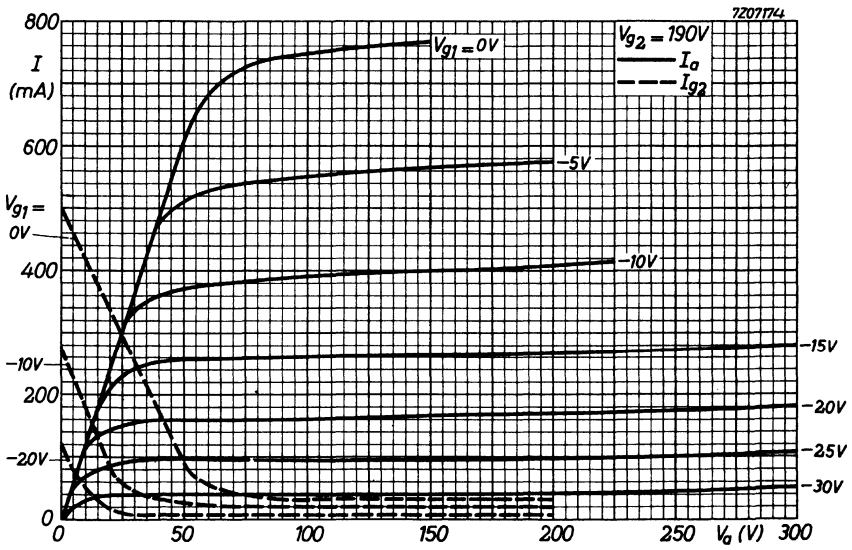
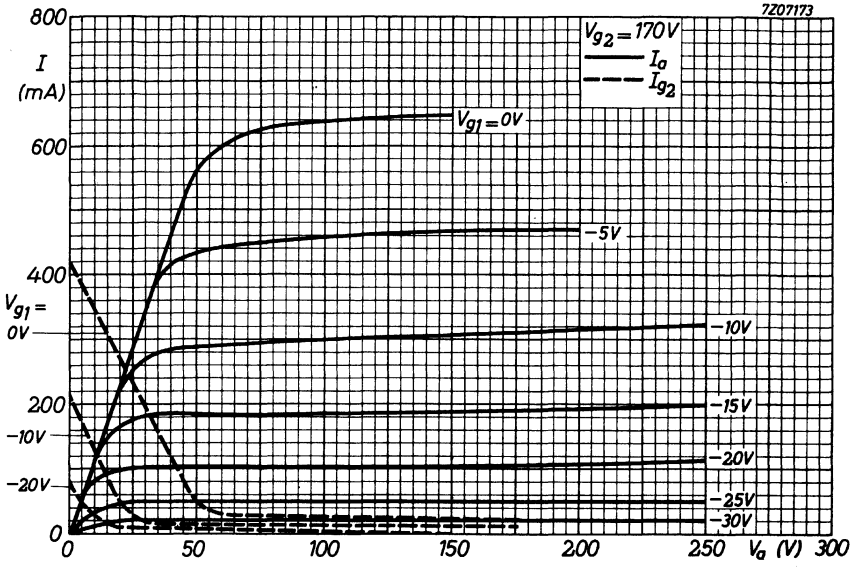



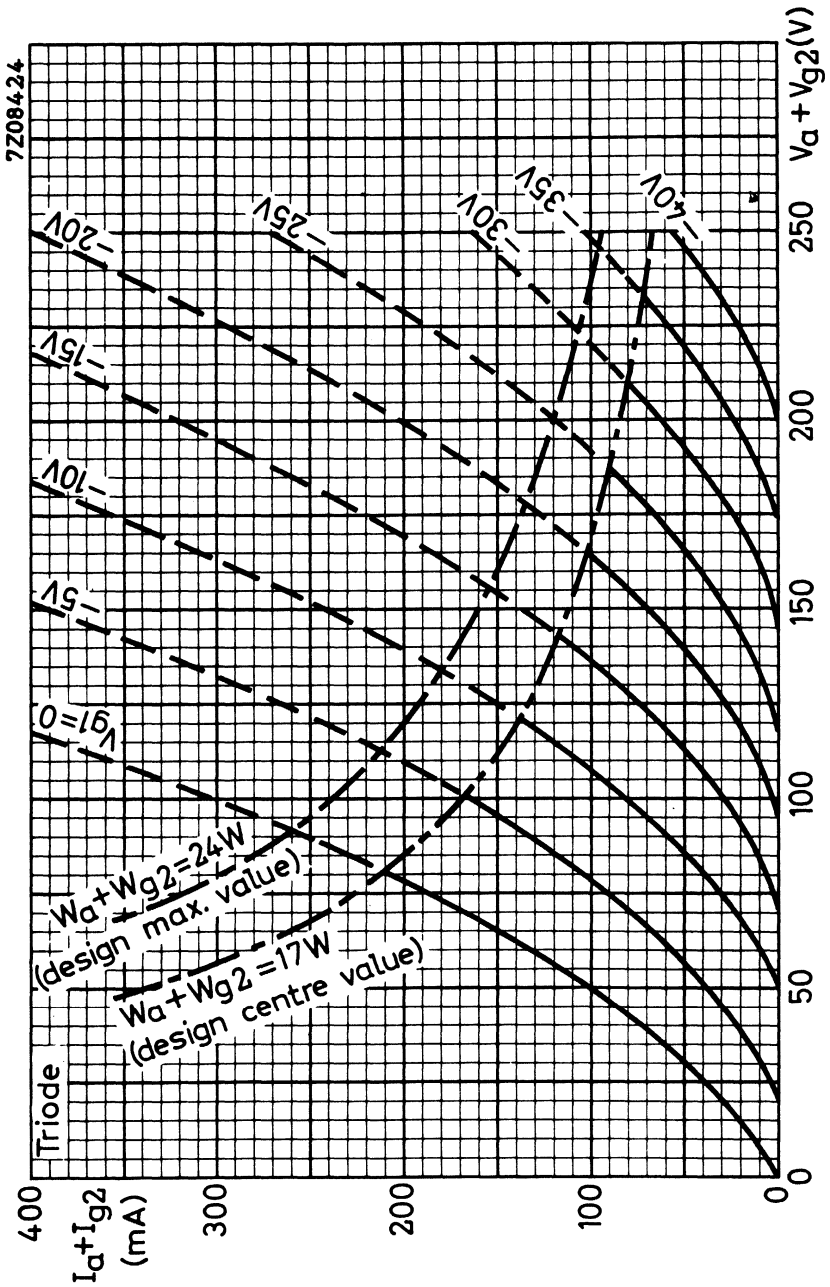



## LINE OUTPUT PENTODE

Output pentode intended for colour TV line deflection circuits.

| QUICK REFERENCE DATA |          |          |    |
|----------------------|----------|----------|----|
| Anode peak voltage   | $V_{ap}$ | 7000     | V  |
| Cathode current      | $I_k$    | max. 500 | mA |
| Anode dissipation    | $W_a$    | max. 25  | W  |

### LIMITING VALUES (Design centre rating system)

|   |              |         |   |
|---|--------------|---------|---|
| Anode dissipation                                 | $W_a$        | max. 25 | W |
| Anode + grid No. 2 dissipation (triode connected) | $W_a+W_{g2}$ | max. 26 | W |

(Design max. rating system)<sup>1)</sup>

|   |              |         |   |
|---|--------------|---------|---|
| Anode dissipation                                 | $W_a$        | max. 34 | W |
| Anode + grid No. 2 dissipation (triode connected) | $W_a+W_{g2}$ | max. 35 | W |

-----  
 For further data and curves of this type  
 please refer to type PL 509  
 -----

<sup>1)</sup> The design maximum limits should not be exceeded with a nominal tube under the worst probable operating conditions at a normal picture width.



## FRAME OUTPUT PENTODE

Pentode intended for use as frame output amplifier in colour television receivers.

| QUICK REFERENCE DATA     |                   |
|--------------------------|-------------------|
| Cathode current, average | $I_k$ max. 100 mA |
| Anode dissipation        | $W_a$ max. 12 W   |

**HEATING:** Indirect by A.C. or D.C.; series supply

|                |              |
|----------------|--------------|
| Heater current | $I_f$ 300 mA |
| Heater voltage | $V_f$ 17 V   |

### DIMENSIONS AND CONNECTIONS

Dimensions in mm

Base: Magnoval

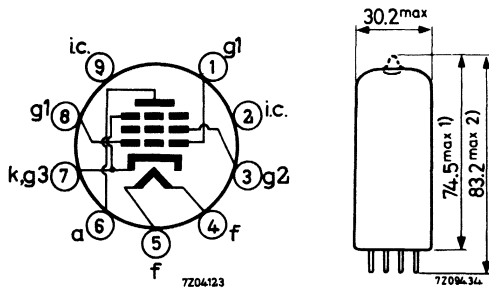

### CAPACITANCES

|                      |                       |
|----------------------|-----------------------|
| Anode to grid No. 1  | $C_{ag1}$ max. 1.6 pF |
| Grid No. 1 to heater | $C_{g1f}$ max. 0.2 pF |

1) Max. 71.4  
 2) Max. 80.1 for execution with pumping stem on base side.

**TYPICAL CHARACTERISTICS**

(Measured under pulse conditions)

|                      |          |            |              |        |
|----------------------|----------|------------|--------------|--------|
| Anode voltage        | $V_a$    | 50         | $V_a$        | 190 V  |
| Grid No.2 voltage    | $V_{g2}$ | 190        | $V_{g2}$     | 190 V  |
| Grid No.1 voltage    | $V_{g1}$ | -1         | $V_{g1}$     | -17 V  |
| Anode current        | $I_{ap}$ | 320        | $I_a$        | 60 mA  |
| Grid No.2 current    | $I_{g2}$ | approx. 60 | $I_{g2}$     | 5 mA   |
| Transconductance     |          |            | S            | 9 mA/V |
| Amplification factor |          |            | $\mu_{g2g1}$ | 8 -    |

Remarks.

The minimum  $I_a$  to be expected as a result of spread of the tube characteristics tube deterioration during life and decrease of the mains voltage to 10 % below the nominal value can be derived from the curves on page B by decreasing by 40 % the  $I_a$  values situated on the curve A-B at  $V_{g2}$  occurring at the decreased mains voltage.

In order not to exceed the maximum permissible value of  $W_{g2}$ , the circuit should be designed in such a way that the anode voltage should never be lower than the value determined by curve A-B at the relevant  $V_{g2}$  value.

**OPERATING CHARACTERISTICS** (end of scan values)

|                    |          |        |
|--------------------|----------|--------|
| Anode voltage      | $V_a$    | 70 V   |
| Grid No.2 voltage  | $V_{g2}$ | 200 V  |
| Grid No.1 voltage  | $V_{g1}$ | -5 V   |
| Anode peak current | $I_{ap}$ | 230 mA |

**LIMITING VALUES** (design centre rating system) unless otherwise stated

|                                |            |      |               |
|--------------------------------|------------|------|---------------|
| Anode voltage                  | $V_{a_0}$  | max. | 700 V         |
|                                | $V_a$      | max. | 400 V         |
| Anode peak voltage             | $V_{ap}$   | max. | 2.5 kV 1 )    |
| Grid No.2 voltage              | $V_{g2_0}$ | max. | 700 V         |
|                                | $V_{g2}$   | max. | 275 V         |
| Anode dissipation              | $W_a$      | max. | 12 W          |
| Grid No.2 dissipation          | $W_{g2}$   | max. | 3 W           |
| design max.                    | $W_{g2}$   | max. | 4 W           |
| Cathode current                | $I_k$      | max. | 100 mA        |
| Grid No.1 resistor, fixed bias | $R_{g1}$   | max. | 1 $M\Omega$   |
| automatic bias                 | $R_{g1}$   | max. | 2.2 $M\Omega$ |
| Cathode to heater voltage      | $V_{kf}$   | max. | 220 V         |

**MICROPHONY**

The maximum peak acceleration to which the tube may be subjected under the most unfavourable conditions is 1.5 g at frequencies < 600 Hz. and 0.2 g at frequencies > 600 Hz. The equivalent interference voltage at grid No.1 will than be < 25 mV.

1) Max. pulse duration 5% of a cycle and max. 1 ms.

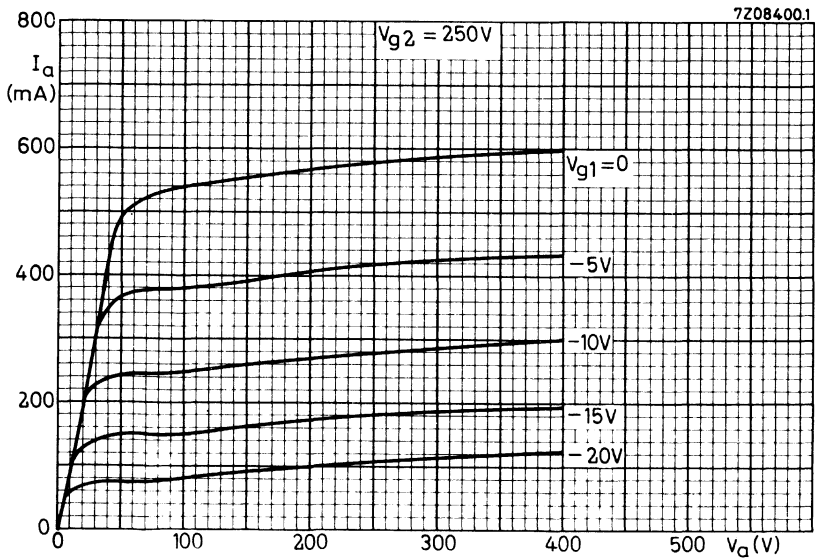
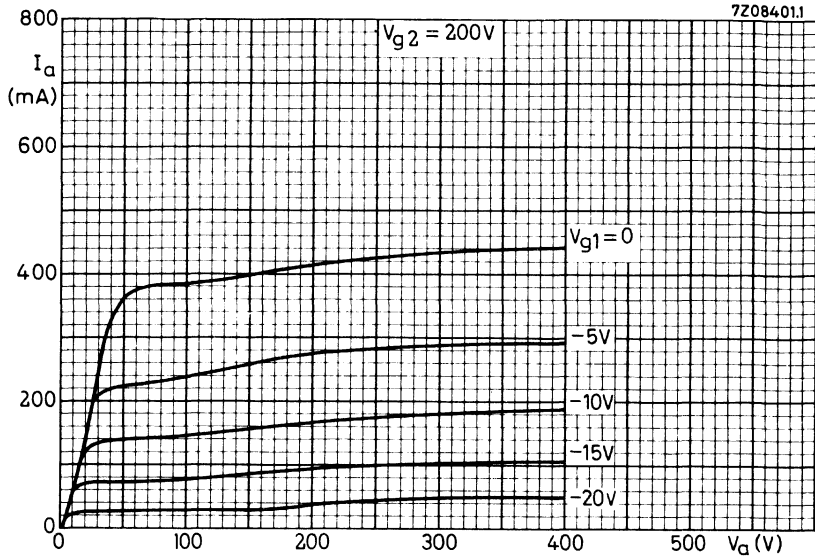



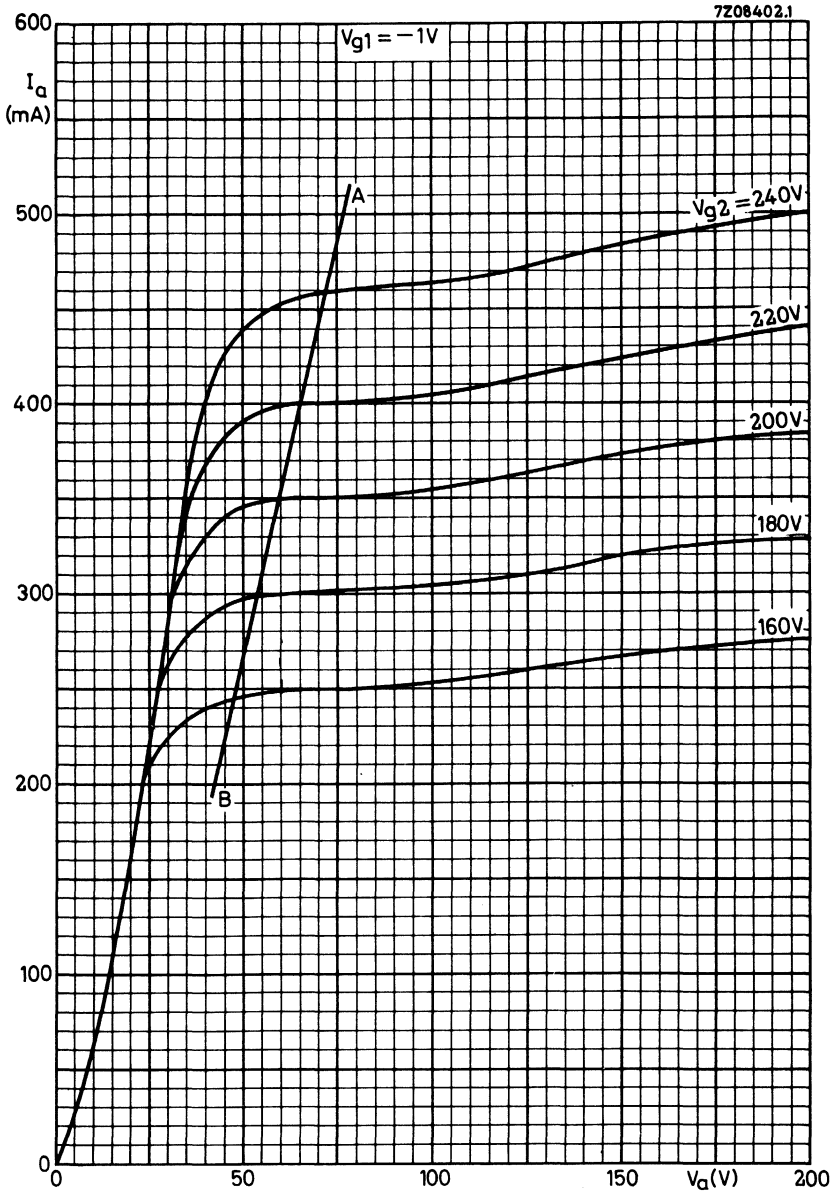



## LINE OUTPUT PENTODE

Output pentode intended for colour TV line deflection circuits.

| QUICK REFERENCE DATA |          |             |
|----------------------|----------|-------------|
| Anode peak voltage   | $V_{ap}$ | 7000 V      |
| Cathode current      | $I_k$    | max. 500 mA |
| Anode dissipation    | $W_a$    | max. 30 W   |

**HEATING:** Indirect by A.C. or D.C.; series supply

Heater current

$I_f$  300 mA

Heater voltage

$V_f$  40 V

### DIMENSIONS AND CONNECTIONS

Dimensions in mm

Base: Magnoval

Top cap: Type 1

Mounting: Additional supporting of the tube at the top is required.

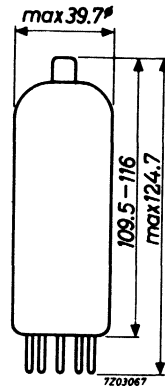
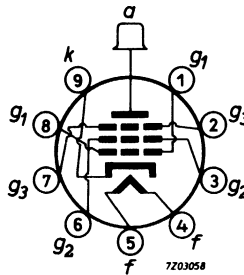

### CAPACITANCES

Grid No.1 to filament

$C_{g1f}$  max. 0.2 pF

Anode to grid No.1

$C_{ag1}$  max. 3.0 pF

$C_{g1}$  2.5 pF

**TYPICAL CHARACTERISTICS** (measured under pulse conditions)

|                   |           |      |        |
|-------------------|-----------|------|--------|
| Anode voltage     | $V_a$     | 160  | 50 V   |
| Grid No.3 voltage | $V_{g_3}$ | 0    | 0 V    |
| Grid No.2 voltage | $V_{g_2}$ | 160  | 175 V  |
| Grid No.1 voltage | $V_{g_1}$ | 0    | -10 V  |
| Anode current     | $I_a$     | 1400 | 800 mA |
| Grid No.2 current | $I_{g_2}$ | 45   | 70 mA  |

**OPERATING CONDITIONS** (D.C. feedback)

Cut-off voltage

The minimum required cut-off voltage ( $-V_{g_1}$ ) during flyback at  $V_a = 7000$  V and at line frequency is at :

$$\begin{aligned} V_{g_2} = 150 \text{ V} : V_{g_1} &= -175 \text{ V} \\ V_{g_2} = 200 \text{ V} : V_{g_1} &= -195 \text{ V} \\ V_{g_2} = 250 \text{ V} : V_{g_1} &= -215 \text{ V} \end{aligned}$$

Supply voltages: See pages 4-5-6

Minimum required anode voltage:  $V_a \text{ min}$

In order to prevent Barkhausen interference and loss of stabilization, care should be taken that the anode voltage never drops below the specified  $V_a \text{ min}$  during the scanning period.

If low values of  $V_a \text{ min}$  are required, the  $V_a \text{ min}$  l-line can be shifted over 10 V to  $V_a \text{ min } 2$ , provided a D.C. voltage of at least +20 V is applied to the beamplate ( $g_3$ ). To compensate for the influence of mains voltage variations, the specified values of  $V_a \text{ min}$  have to be increased with 10% of the anode supply voltage.

Minimum required values of the screen grid voltage:  $V_{g_2 \text{ min}}$

The graph refers to nominal mains voltage. The specified values of  $I_{a_p}$  will be available throughout life of the tube at supply voltages 10% below nominal.

Maximum permissible screen grid series resistance:  $R_{g_2 \text{ max}}$ . See pages 4-5-6

Decoupling-capacitors in the grid no 2 and/or grid no 3 circuit

In circuits where decoupling capacitors in the grid no 2 or the grid no 3 circuits are applied, incidental flashover in the tube may give rise to excessive discharge currents and component or tube failure.

Therefore it is recommended to limit the discharge currents to these capacitors by means of an 100 Ohm resistance between  $g_2$  and the  $g_2$ -bypass capacitance.

The 1000 Ohms resistance should be protected by a spark-gap connected between  $g_3$  and earth.

Hum

At  $Z_{g_1} = 200 \text{ k}$  ( $f = 50 \text{ Hz}$ ),  $V_{k/f} = 220 \text{ V}_{\text{RMS}}$  and without wiring and socket capacitance, the equivalent grid hum voltage is less than 5 mV.

**LIMITING VALUES**

Anode voltage in cold condition  
 Anode peak voltage  
 Anode dissipation  
 Anode + grid No.2 dissipation (triode-connected)  
 Grid No.3 voltage  
 Grid No.2 voltage in cold condition  
 Grid No.2 voltage  
 Grid No.2 dissipation  
 Cathode current  
 Cathode peak current  
 Cathode-to-heater voltage  
 Grid No.1 resistor: fixed bias  
 . stabilized circuits  
 Grid No.3 circuit resistance  
 Bulb temperature

Design centre rating system

|                |      |                      |
|----------------|------|----------------------|
| $V_{ao}$       | max. | 700 V                |
| $V_{ap}$       | max. | 7000 V <sup>1)</sup> |
| $W_a$          | max. | 30 W                 |
| $W_a + W_{g2}$ | max. | 31 W                 |
| $V_{g3}$       | max. | 50 V                 |
| $V_{g2o}$      | max. | 700 V                |
| $V_{g2}$       | max. | 275 V                |
| $W_{g2}$       | max. | 7 W <sup>2)</sup>    |
| $I_k$          | max. | 500 mA               |
| $I_{kp}$       | max. | 1200 mA              |
| $V_{kf}$       | max. | 250 V                |
| $R_{g1}$       | max. | 0.5 MΩ <sup>3)</sup> |
| $R_{g1}$       | max. | 2.2 MΩ <sup>3)</sup> |
| $R_{g3}$       | max. | 10 kΩ <sup>4)</sup>  |
| $t_{bulb}$     | max. | 300 °C <sup>5)</sup> |

Design max. rating system <sup>6)</sup>

Anode dissipation  
 Anode + grid No.2 dissipation (triode connected)  
 Grid No.2 dissipation  
 Anode peak voltage  
 Neg. grid No.1 peak voltage

|                |      |                      |
|----------------|------|----------------------|
| $W_a$          | max. | 40 W                 |
| $W_a + W_{g2}$ | max. | 42 W                 |
| $W_{g2}$       | max. | 9 W                  |
| $V_{ap}$       | max. | 8000 V <sup>1)</sup> |
| $-V_{g1p}$     | max. | 550 V <sup>1)</sup>  |

1. Max. pulse duration is 22% of a cycle and max. 18 μs.
2. To prevent an excessive value of  $W_{g2}$  the minimum  $R_{g2}$  values are given in the graph below.

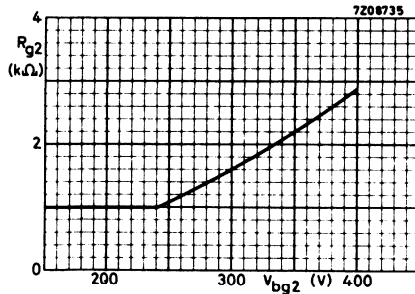

3. The circuit design has to be such that negative control grid currents up to 5 micro-amperes do not have any detrimental effect upon tube adjustment or circuit performance.

Care should be taken that with 5 micro-amperes grid current the limiting values for  $I_k$ ,  $W_a$  and  $W_{g2}$  are not exceeded.

4. With  $R_{g3} \leq 10$  kΩ capacitive decoupling of  $g_3$  is not required.
5. Absolute max. value.
6. The design maximum limits should not be exceeded with a nominal tube under the worst probable operating conditions at a normal picture width.

Min. required anode voltage.

$R_{g2 \text{ max}}$  : max. permissible screen grid series resistance for 400 V screen grid supply.

The specified values of  $I_{ap}$  are available at supply voltages 10% below nominal and throughout the tube life.

Remark:  $R_{g2 \text{ min}}$  for 400 V screen grid supply is 2.9 k $\Omega$ . (See page 3)

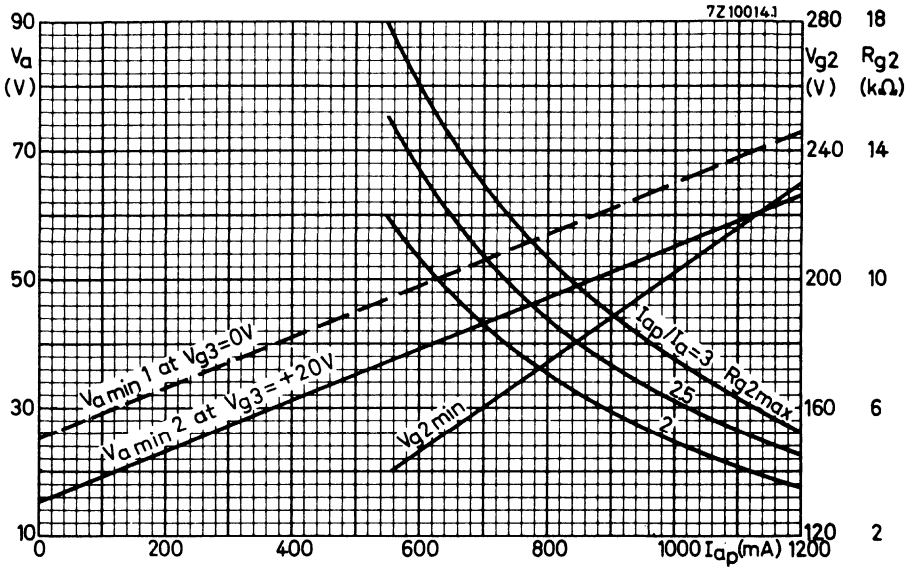

Min. required anode voltage.

$R_{g2 \text{ max}}$  : max. permissible screen grid series resistance for 350 V screen grid supply.

The specified values of  $I_{ap}$  are available at supply voltages 10% below nominal and throughout the tube life.

Remark:  $R_{g2 \text{ min}}$  for 350 V screen grid supply is 2.2 k $\Omega$ . (See page 3)

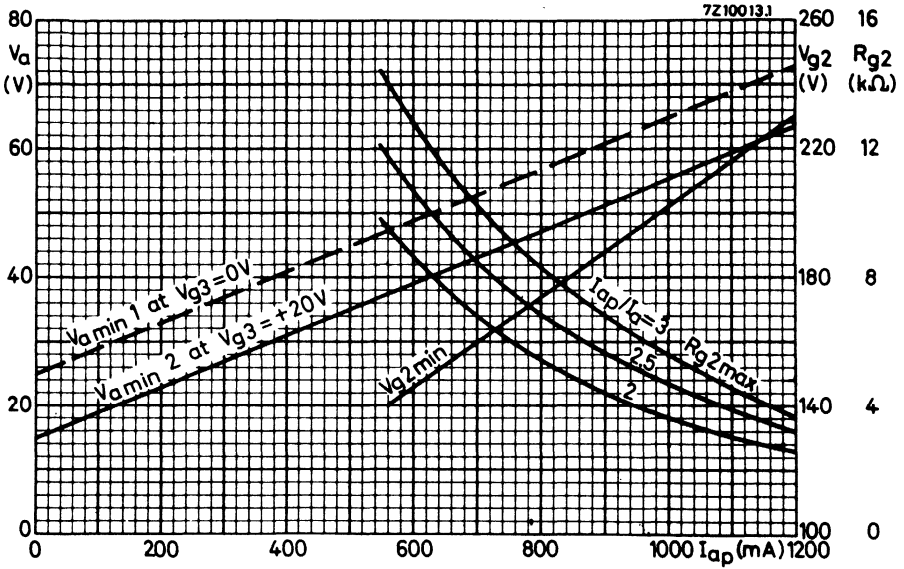

Min. required anode voltage.

$R_{g2} \text{ max.}$ : max. permissible screen grid series resistance for 280 V screen grid supply.

The specified values of  $I_{ap}$  are available at supply voltages 10% below nominal and throughout the tube life.

Remark:  $R_{g2} \text{ min}$  for 280 V screen grid supply is 1.4 k $\Omega$ . (See page 3)

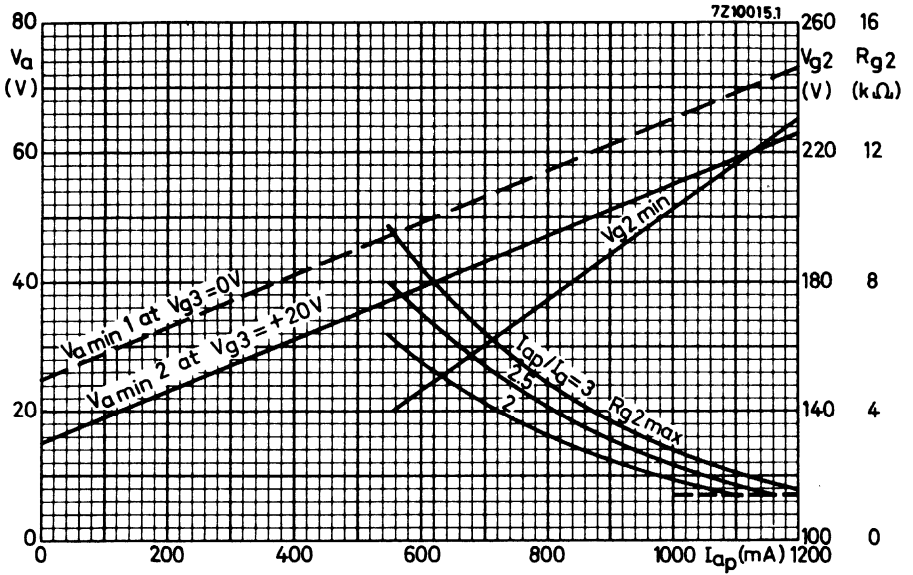



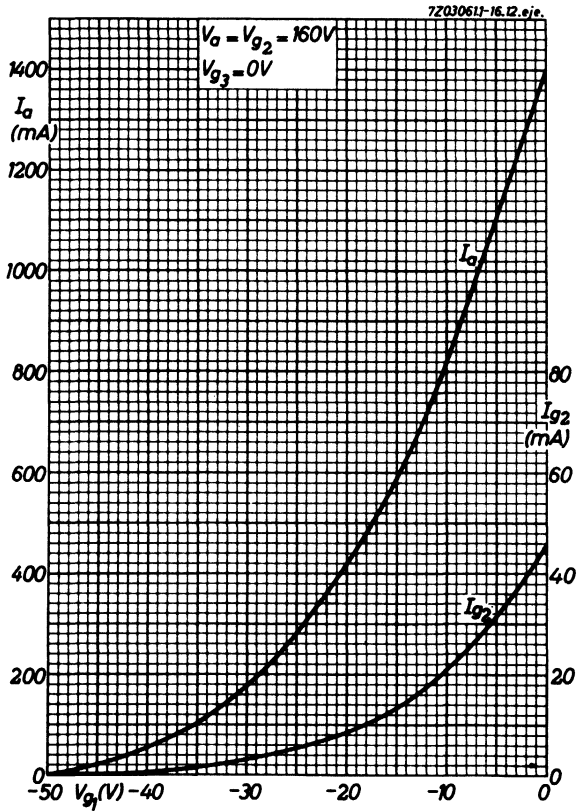

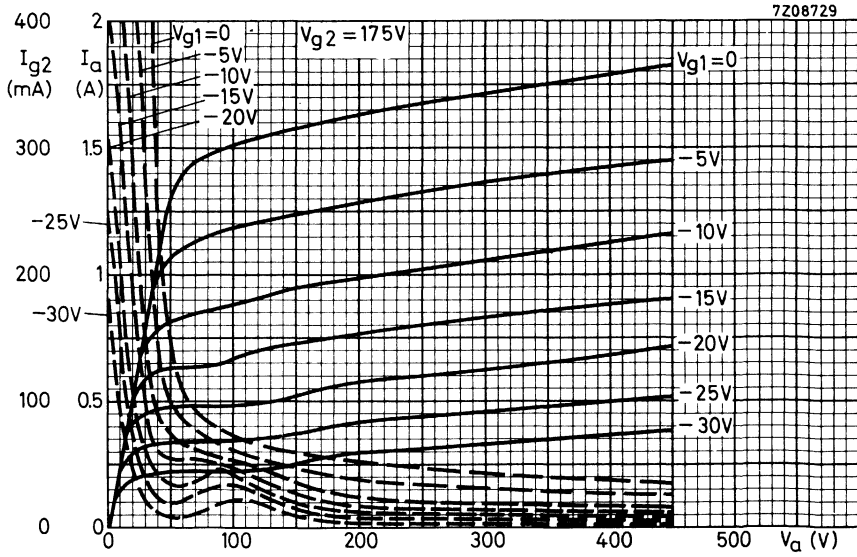
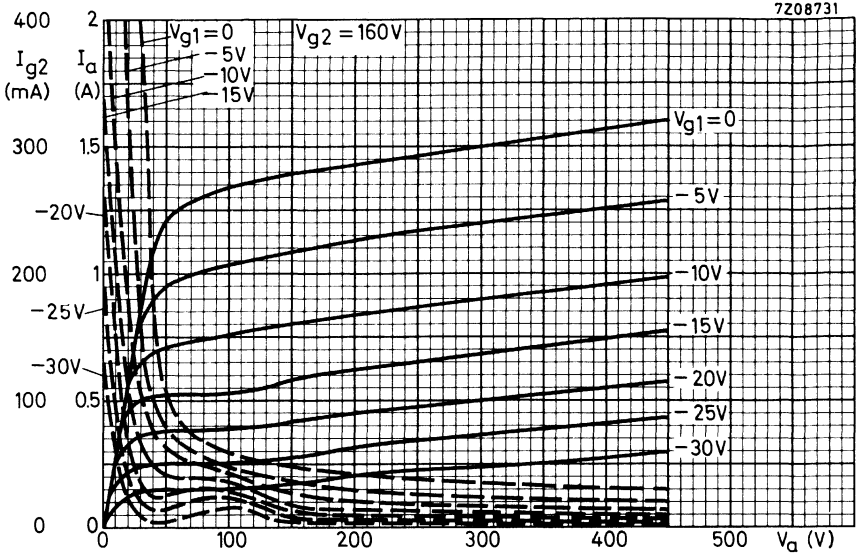

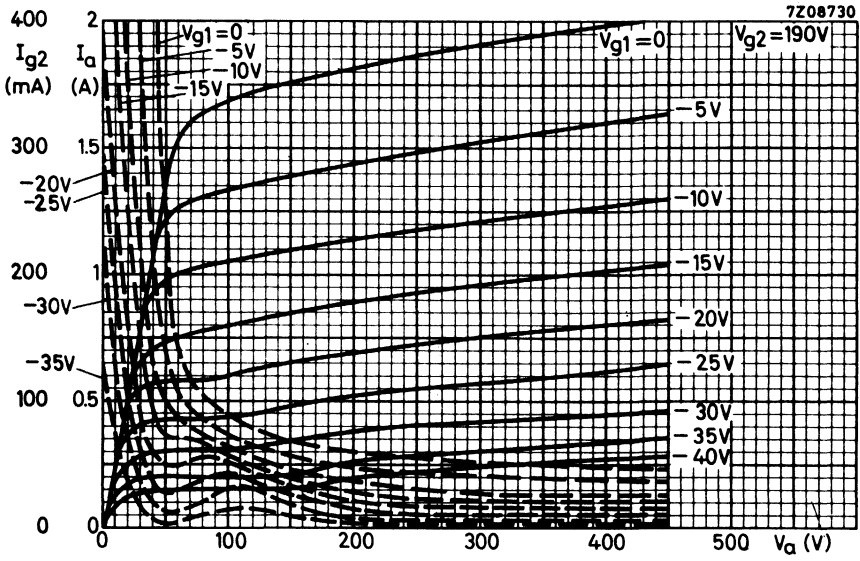



## LINE OUTPUT PENTODE

Output pentode intended for colour TV line deflection circuits.

**HEATING:** Indirect by A. C. or D. C. ; series supply

Heater current

$I_f$  300 mA

Heater voltage

$V_f$  40 V

### DIMENSIONS AND CONNECTIONS

Base: Magnoval

Top cap: Type 1

Mounting: Additional supporting of the tube at the top is required.

Dimensions in mm

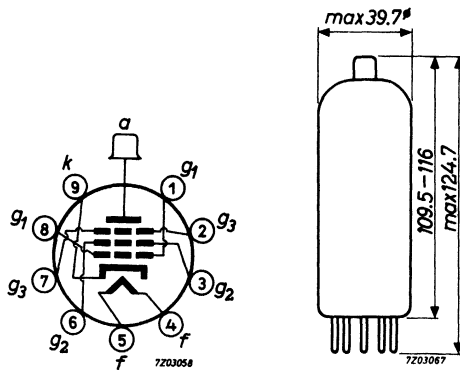

### CAPACITANCES

Grid No. 1 to filament

$C_{g1f}$  max. 0.2 pF

Anode to grid No. 1

$C_{ag1}$  max. 3.0 pF

$C_{ag1}$  2.5 pF

**TYPICAL CHARACTERISTICS** (measured under pulse conditions)

|                    |          |      |     |      |    |
|--------------------|----------|------|-----|------|----|
| Anode voltage      | $V_a$    | 160  | 50  | 70   | V  |
| Grid No. 3 voltage | $V_{g3}$ | 0    | 0   | 0    | V  |
| Grid No. 2 voltage | $V_{g2}$ | 160  | 175 | 205  | V  |
| Grid No. 1 voltage | $V_{g1}$ | 0    | -10 | -11  | V  |
| Anode current      | $I_a$    | 1400 | 800 | 1100 | mA |
| Grid No. 2 current | $I_{g2}$ | 45   | 70  | 85   | mA |

**OPERATING CONDITIONS** (D.C. feedback)

Cut-off voltage

The minimum required cut-off voltage ( $-V_{g1}$ ) during flyback at  $V_a = 7000$  V and at line frequency is at :

$$\begin{aligned} V_{g2} = 150 \text{ V} : V_{g1} &= -175 \text{ V} \\ V_{g2} = 200 \text{ V} : V_{g1} &= -195 \text{ V} \\ V_{g2} = 250 \text{ V} : V_{g1} &= -215 \text{ V} \end{aligned}$$

Minimum required anode voltage during the scanning period :  $V_a$  min. See page 6

Minimum required screen grid voltage :  $V_{g2}$  min. See page 4, 5

Recommended screen grid series resistor :  $R_{g2}$  rec See page 4, 5

Decoupling capacitors in the grid no. 2 and/or grid no. 3 circuit

In circuits where decoupling capacitors in the grid no. 2 or the grid no. 3 circuits are applied, incidental flashover in the tube may give rise to excessive discharge currents and component or tube failure.

Therefore it is recommended to limit the discharge currents from these capacitors by means of a  $100 \Omega$  resistor between  $g_2$  and the  $g_2$ -bypass capacitor and a  $1000 \Omega$  resistor between  $g_3$  and the  $g_3$ -bypass capacitor. The  $1000 \Omega$  resistor should be protected by a spark-gap connected between  $g_3$  and earth.

Hum

At  $Z_{g1} = 200 \text{ k}\Omega$  ( $f = 50 \text{ Hz}$ ),  $V_{kf_{RMS}} = 220 \text{ V}$  and without wiring and socket capacitance, the equivalent grid hum voltage is less than 5 mV.



Min. required  $V_{g2}$  and recommended  $R_{g2}$   
 Non-stabilized supply voltages.

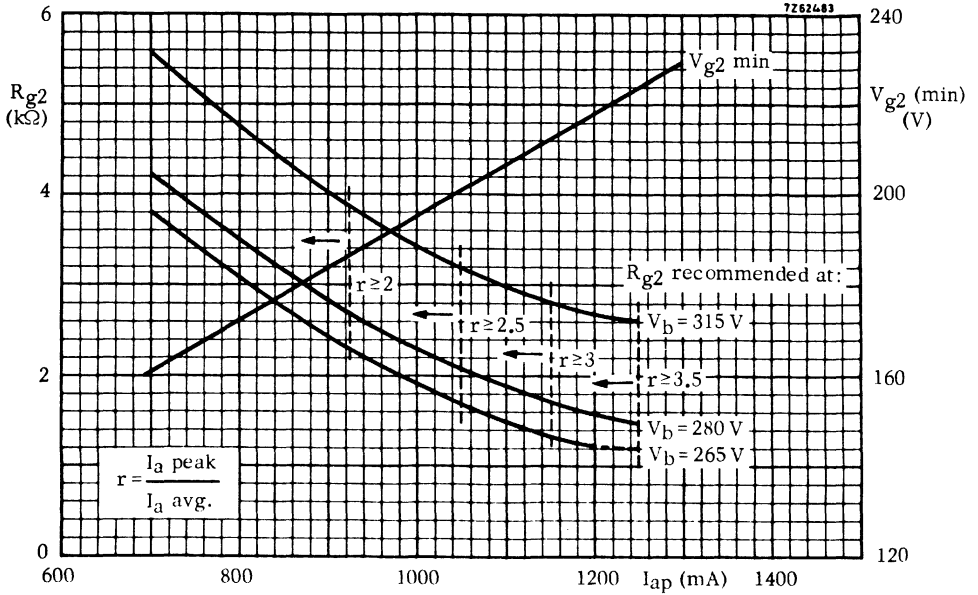



Min. required  $V_{g2}$  and recommended  $R_{g2}$   
 Stabilized supply voltage.

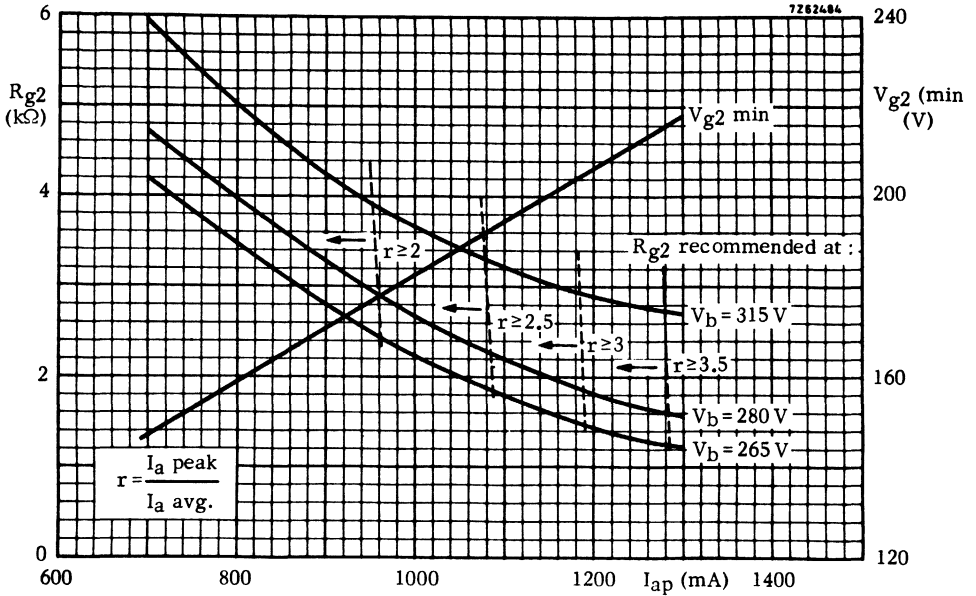

The above graphs concern the design of a line-output circuit adjusted at a beam current of 1000  $\mu$ A and a nominal mains voltage.

If the recommended  $R_{g2}$  is used,  $V_{g2}$  will be equal to higher or than the specified  $V_{g2}$  min. and there will be adequate reserve in anode peak current throughout the life of the tube. (Tolerances of deflection-components and 10 % mains voltage fluctuations taken into account).

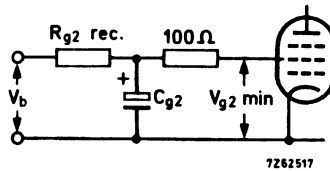

Min. required anode voltage, during the scanning period.

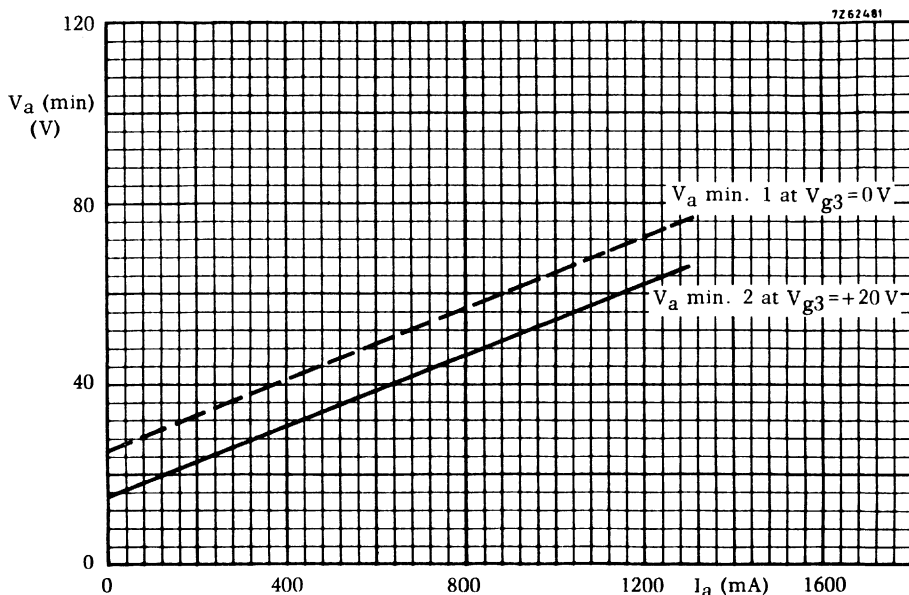

To suppress Barkhausen interference and to ensure stability, the anode load line should not be allowed to drop below the  $V_a$  line shown in the diagram. If  $V_a$  min. must be low, the  $V_a$  min. 1-line can be shifted over 10 V to  $V_a$  min. 2, provided a D.C. voltage of at least +20 V is applied to the beam plate ( $g_3$ ). To compensate for the influence of mains voltage fluctuations, the specified values of  $V_a$  min. must be increased with 10 % of the anode supply voltage when not stabilized.

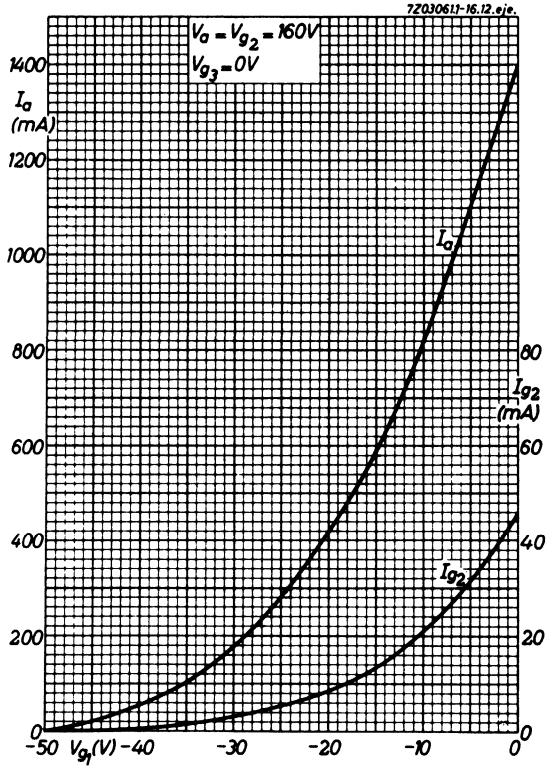

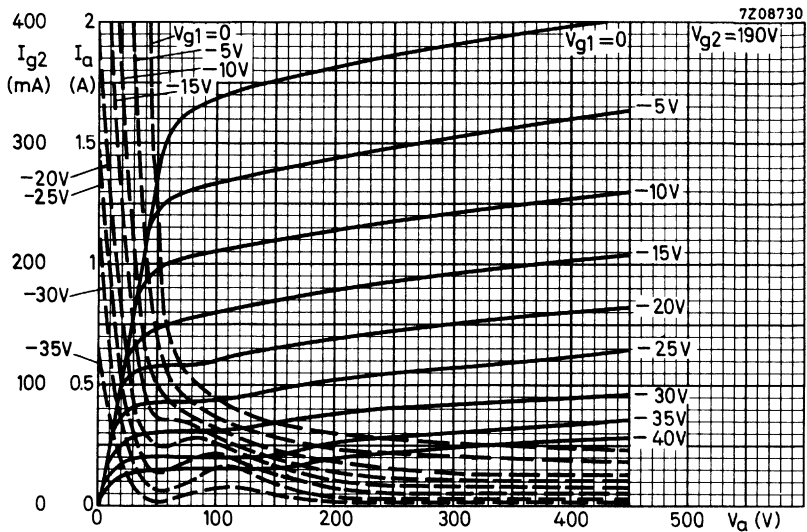

## VIDEO OUTPUT PENTODE

Luminance output tube in colour TV receivers.

| QUICK REFERENCE DATA |       |          |
|----------------------|-------|----------|
| Anode current        | $I_a$ | 30 mA    |
| Transconductance     | $S$   | 40 mA/V  |
| Anode dissipation    | $W_a$ | max. 6 W |

**HEATING:** Indirect by A.C. or D.C.; series supply

|                |       |        |
|----------------|-------|--------|
| Heater current | $I_f$ | 300 mA |
| Heater voltage | $V_f$ | 16 V   |

### DIMENSIONS AND CONNECTIONS

Dimensions in mm

Base: Noval

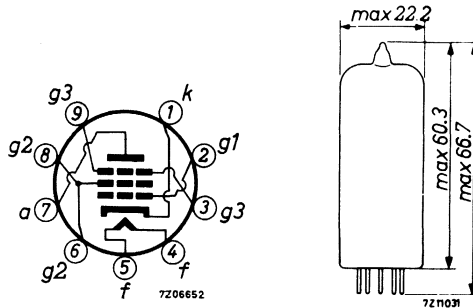

### CAPACITANCES

|                                |                 |          |
|--------------------------------|-----------------|----------|
| Anode to all except grid No. 1 | $C_{a(g_1)}$    | 4 pF     |
| Grid No. 1 to all except anode | $C_{g_1(a)}$    | 20 pF    |
| Anode to grid No. 1            | $C_{ag_1}$      | 0.075 pF |
| Anode to grid No. 1            | $C_{ag_1}$ max. | 0.1 pF   |

**TYPICAL CHARACTERISTICS**

|                              |              |             |
|------------------------------|--------------|-------------|
| Anode voltage                | $V_a$        | 170 V       |
| Grid No.2 voltage            | $V_{g2}$     | 170 V       |
| Grid No.3 voltage            | $V_{g3}$     | 0 V         |
| Grid No.1 supply voltage     | $V_{bg1}$    | 0 V         |
| Cathode resistor (decoupled) | $R_k$        | 36 $\Omega$ |
| Anode current                | $I_a$        | 30 mA       |
| Grid No.2 current            | $I_{g2}$     | 6.5 mA      |
| Transconductance             | $S$          | 40 mA/V     |
| Amplification factor         | $\mu_{g2g1}$ | 70 -        |

**LIMITING VALUES** (Design centre rating system unless otherwise stated)

|                           |           |                     |
|---------------------------|-----------|---------------------|
| Anode supply voltage      | $V_{ba}$  | max. 400 V          |
| Anode voltage,            | $V_{a0}$  | max. 550 V          |
| long term average         | $V_a$     | max. 300 V          |
| Grid No.2 voltage         | $V_{g20}$ | max. 550 V          |
|                           | $V_{g2}$  | max. 300 V          |
| Anode dissipation         | $W_a$     | max. 6 W            |
| Grid No.2 dissipation     | $W_{g2}$  | max. 2.5 W          |
|                           | $W_{g2}$  | max. 3.0 W 1)       |
| Cathode current           | $I_k$     | max. 100 mA         |
| Grid No.1 resistor        | $R_{g1}$  | max. 0.1 M $\Omega$ |
| at $R_k \geq 39 \Omega$   | $R_{g1}$  | max. 0.5 M $\Omega$ |
| Cathode to heater voltage | $V_{kf}$  | max. 200 V          |

<sup>1)</sup> Design maximum rating system including no signal condition.

**OPERATING CONDITIONS** (negative modulation)

- $V_b = 250 \text{ V}$
- $R_b = 330 \text{ } \Omega$
- $R_{av} = 560 \text{ } \Omega$
- $R_a = 2.7 \text{ k}\Omega$
- $R_{g2} = 5.6 \text{ k}\Omega$
- $R_k^1) = 39 \text{ } \Omega$
- $+V_{bg1} = 4 \text{ V}$

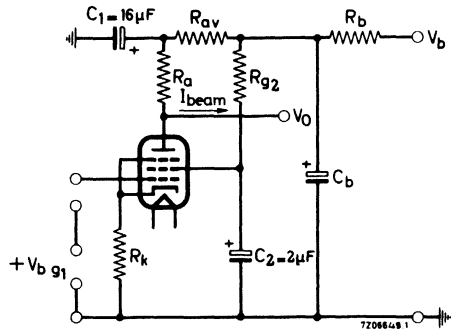

fig.1

- $V_{o1} = 100 \text{ V}$
- $V_{opp} \cong 140 \text{ V}$
- Video-linearity  $\cong 0.8 -$
- $V_{ipp} \text{ ca. } 5 \text{ V}$
- $I_{beam} \text{ max. } 7 \text{ mA}$

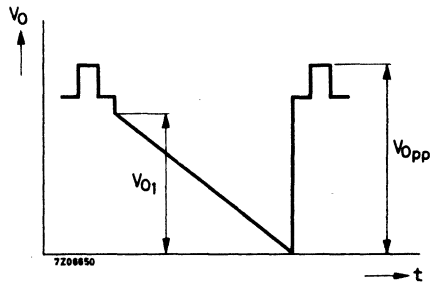
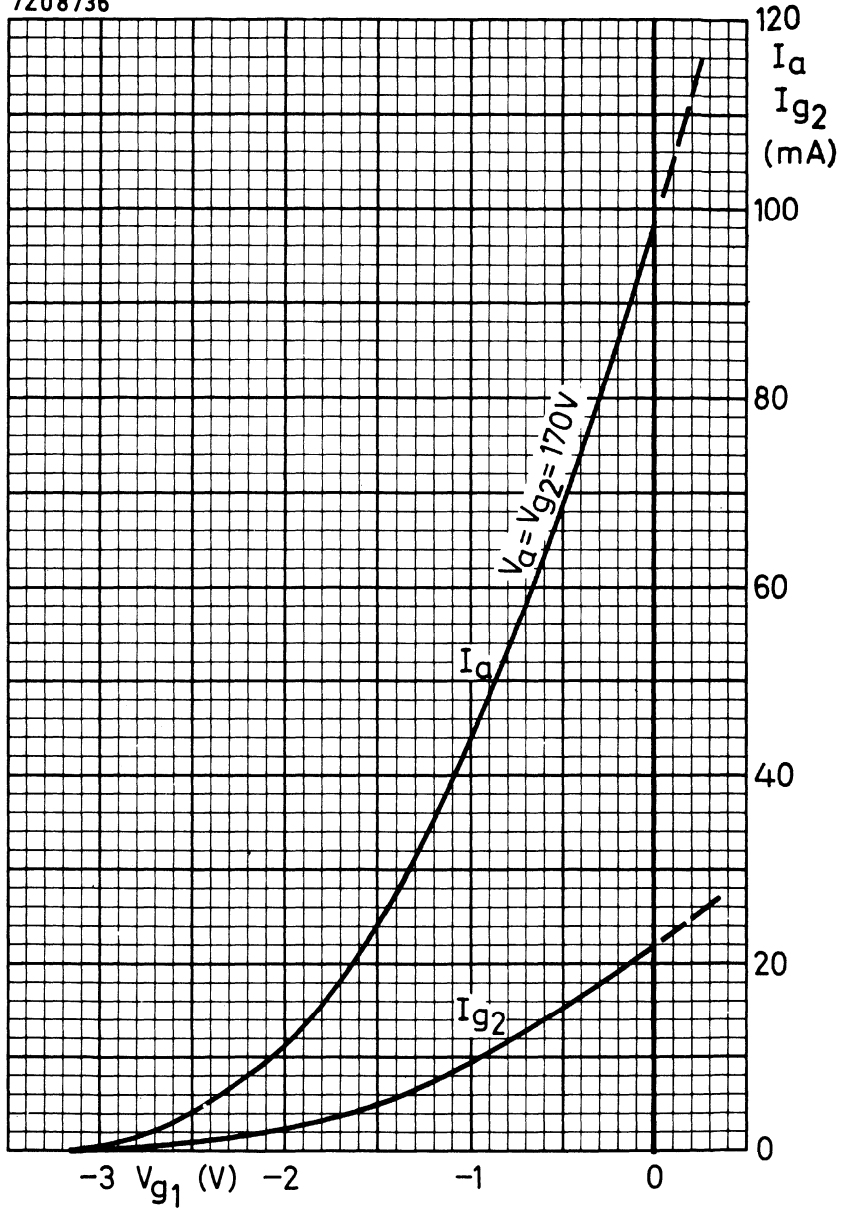

fig.2

1) Without by-pass capacitor.

7Z08736





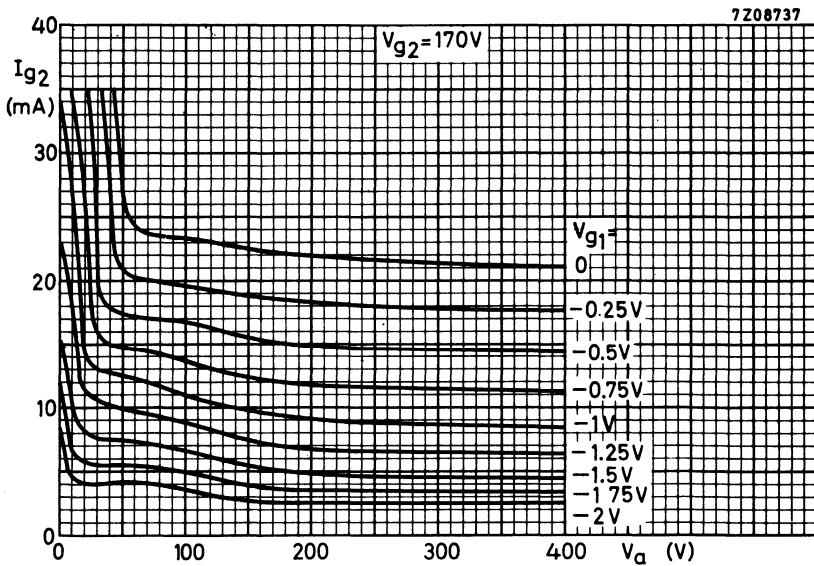
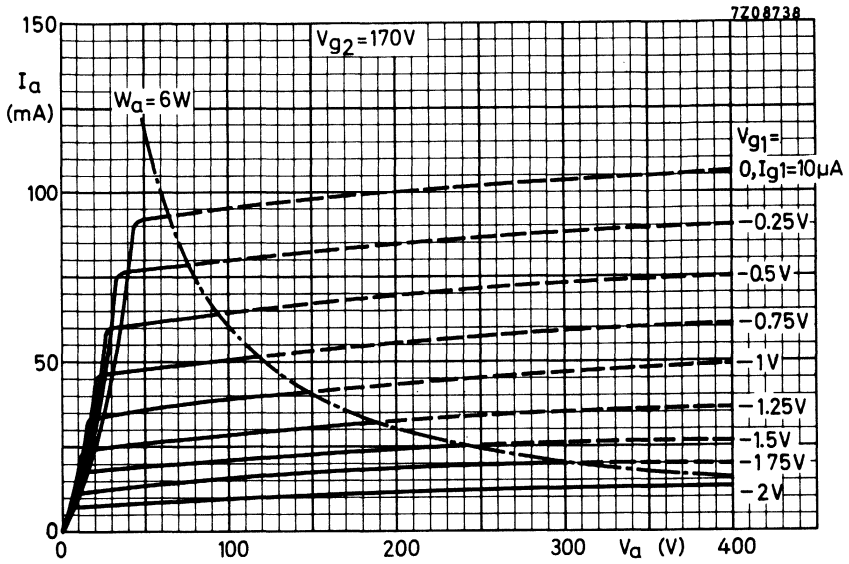



## BOOSTER DIODE

Booster diode intended for use in line time-base circuits of transformerless television receivers.

| QUICK REFERENCE DATA            |           |             |
|---------------------------------|-----------|-------------|
| Anode current, peak             | $I_{ap}$  | max. 450 mA |
| Anode voltage, peak             | $V_{ap}$  | max. 5000 V |
| Cathode to heater voltage, peak | $V_{kfp}$ | max. 5000 V |

**HEATING:** Indirect by A. C. or D. C. ; series supply

|                |       |        |
|----------------|-------|--------|
| Heater current | $I_f$ | 300 mA |
| Heater voltage | $V_f$ | 17 V   |

### DIMENSIONS AND CONNECTIONS

Dimensions in mm

Base: Noval

Top cap: Type 1

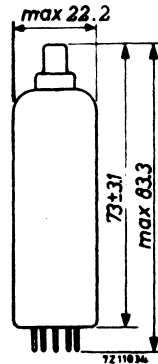
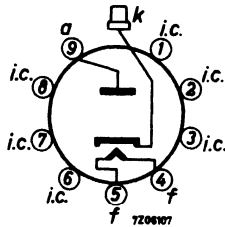

### CAPACITANCES

|                   |          |        |
|-------------------|----------|--------|
| Anode to all      | $C_a$    | 6.4 pF |
| Cathode to heater | $C_{kf}$ | 2.8 pF |

**LIMITING VALUES** (Design centre rating system, unless otherwise specified)

|                                 |             |      |                           |
|---------------------------------|-------------|------|---------------------------|
| Supply voltage                  | $V_{b0}$    | max. | 550 V                     |
|                                 | $V_b$       | max. | 250 V                     |
| Anode dissipation               | $W_a$       | max. | 3.5 W                     |
| Anode current, average          | $I_a$       | max  | 150 mA                    |
| peak                            | $I_{ap}$    | max. | 450 mA                    |
| Anode voltage, peak             | $V_{ap}$    | max  | 5000 V <sup>1)2)</sup>    |
| Absolute max.                   | $V_{ap}$    | max. | 5600 V <sup>1)2)</sup>    |
| Cathode to heater voltage, peak | $V_{kfP}$   | max. | 5000 V <sup>1)</sup>      |
| Series resistance heater chain  | $R_s$       | min. | 80 $\Omega$ <sup>3)</sup> |
| Heater to earth voltage         | $V_f/earth$ | max. | 220 V <sub>RMS</sub>      |

**REMARK**

In general it will be necessary to take measures in order to prevent the maximum permissible screen grid dissipation of the tube that derive their anode voltage from this booster diode, from being exceeded during the heating-up time of the booster diode.

<sup>1)</sup> Max. pulse duration 22% of a cycle with a maximum of 18  $\mu$ sec.

<sup>2)</sup> Cathode positive with respect to the anode.

<sup>3)</sup>  $R_s$  = minimum resistance of the heater chain between any heater pin and any mains terminal under working conditions (the heater of another tube can be used for this resistance).

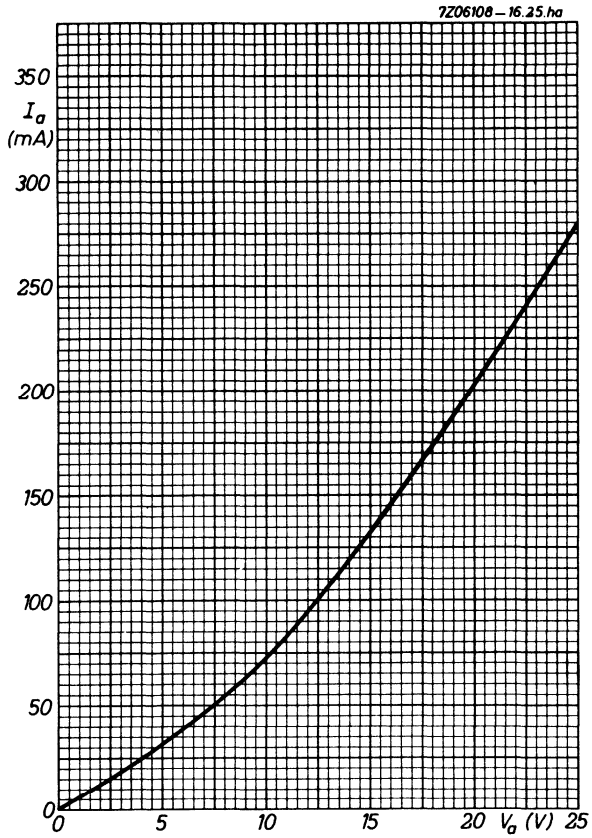



## SINGLE ANODE RECTIFYING TUBE

Single anode high vacuum rectifying tube.

| QUICK REFERENCE DATA |          |     |      |
|----------------------|----------|-----|------|
| Transformer voltage  | $V_{tr}$ | 250 | VRMS |
| D.C. current         | $I_o$    | 180 | mA   |

**HEATING:** Indirect by A.C. or D.C.; series supply

|                |       |     |    |
|----------------|-------|-----|----|
| Heater current | $I_f$ | 300 | mA |
| Heater voltage | $V_f$ | 19  | V  |

### DIMENSIONS AND CONNECTIONS

Dimensions in mm

Base: Noval

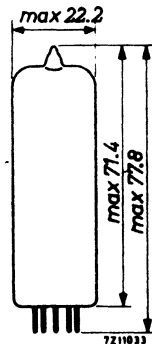
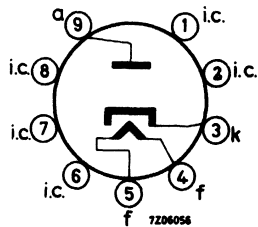

**OPERATING CHARACTERISTICS** as single-phase half-wave rectifier

|                                       |            |     |     |     |     |     |          |
|---------------------------------------|------------|-----|-----|-----|-----|-----|----------|
| Transformer voltage                   | $V_{tr}$   | 250 | 240 | 220 | 200 | 127 | VRMS     |
| D.C. output voltage                   | $V_o$      | 195 | 195 | 195 | 195 | 127 | V        |
| D.C. current                          | $I_o$      | 180 | 180 | 180 | 180 | 180 | mA       |
| Protecting resistance                 | $R_t$      | 125 | 105 | 65  | 30  | 0   | $\Omega$ |
| Input capacitance of smoothing filter | $C_{filt}$ | 60  | 60  | 60  | 60  | 60  | $\mu F$  |

**LIMITING VALUES** (Design centre rating system)

|   |             |      |     |                       |     |     |          |
|---|-------------|------|-----|-----------------------|-----|-----|----------|
| Transformer voltage                             | $V_{tr}$    | max. | 250 | $V_{RMS}$             |     |     |          |
| Anode voltage, peak inverse                     | $V_{ainvp}$ | max. | 700 | V                     |     |     |          |
| D.C. current                                    | $I_o$       | max. | 180 | mA                    |     |     |          |
| Cathode to heater voltage, peak                 | $V_{kfp}$   | max. | 550 | V <sup>1)</sup>       |     |     |          |
| Input capacitance of smoothing filter           | $C_{filt}$  | max. | 60  | $\mu F$ <sup>2)</sup> |     |     |          |
| Protecting resistance<br>at transformer voltage | $R_t$ min.  | 100  | 80  | 40                    | 30  | 0   | $\Omega$ |
|   | $V_{tr}$    | 250  | 240 | 220                   | 200 | 127 | V        |

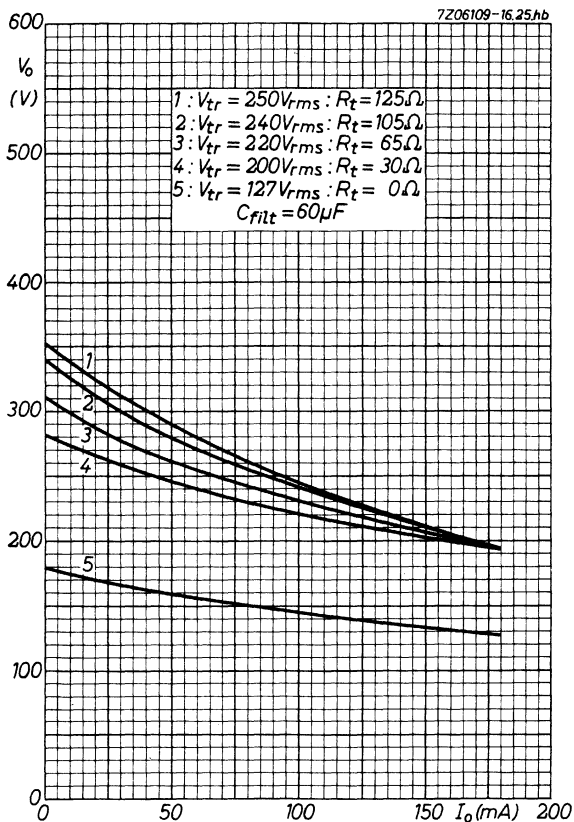

- 1) Max. 220 VRMS A.C. voltage + max. 250 VD.C. voltage.  
Cathode positive with respect to the heater.
- 2) When two tubes are placed in parallel,  $C_{filt} = \text{max. } 100 \mu F$ .  
The resistor  $R_t$  must be inserted in the anode lead of each tube.



## BOOSTER DIODE

Booster diode intended for use in line time-base circuits of transformerless television receivers.

| QUICK REFERENCE DATA            |           |             |
|---------------------------------|-----------|-------------|
| Anode current, peak             | $I_{ap}$  | max. 550 mA |
| Anode voltage, negative peak    | $-V_{ap}$ | max. 6000 V |
| Cathode to heater voltage, peak | $V_{kfp}$ | max. 6600 V |

**HEATING:** Indirect by A.C. or D.C.; series supply

|                |       |        |
|----------------|-------|--------|
| Heater current | $I_f$ | 300 mA |
| Heater voltage | $V_f$ | 30 V   |

### DIMENSIONS AND CONNECTIONS

Dimensions in mm

Base: Noval  
Top cap: Type 1

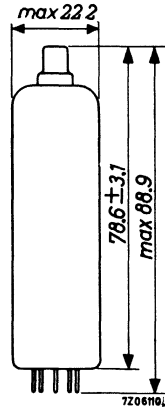
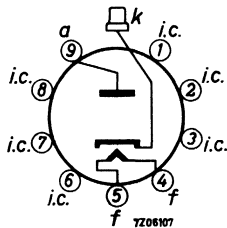

### CAPACITANCES

|                   |          |        |
|-------------------|----------|--------|
| Anode to all      | $C_a$    | 8.6 pF |
| Cathode to heater | $C_{kf}$ | 2.7 pF |

**LIMITING VALUES** (Design centre rating system unless otherwise specified)

|                                 |               |                           |
|---------------------------------|---------------|---------------------------|
| Supply voltage                  | $V_{b0}$      | max. 550 V                |
|                                 | $V_b$         | max. 250 V                |
| Anode dissipation               | $W_a$         | max. 5 W                  |
| Anode current, average          | $I_a$         | max. 220 mA               |
| peak                            | $I_{ap}$      | max. 550 mA               |
| Anode voltage, negative peak    | $-V_{ap}$     | max. 6000 V <sup>1)</sup> |
| negative peak (absolute max.)   | $-V_{ap}$     | max. 7500 V <sup>1)</sup> |
| Cathode to heater voltage, peak | $V_{kfP}$     | max. 6600 V <sup>1)</sup> |
| Heater to earth voltage         | $V_{f/earth}$ | max. 220 VRMS             |

Series resistance heater chain

During operation, the external resistance between either heater pin of the PY88 and either mains terminal should be at least 80  $\Omega$  when  $V_{f/earth} = 220$  VRMS  
 40  $\Omega$  when  $V_{f/earth} = 110$  VRMS

The hot heater resistances of other tubes in the heater chain can serve for this purpose.

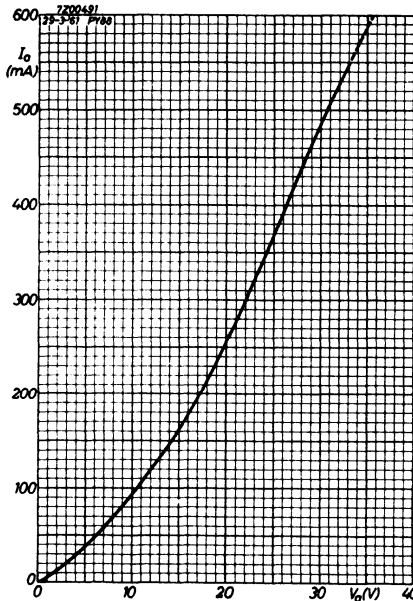

<sup>1)</sup> Max. pulse duration 22% of a cycle but maximum 18  $\mu s$ .

## BOOSTER DIODE

Booster diode for timebase circuits of colour TV receivers.

**HEATING:** Indirect by A.C. or D.C.; series supply

Heater current

$I_f$  300 mA

Heater voltage

$V_f$  42 V

### MECHANICAL DATA

Dimensions in mm

Base: Magnoval

Cap: Type 1

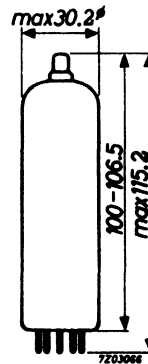
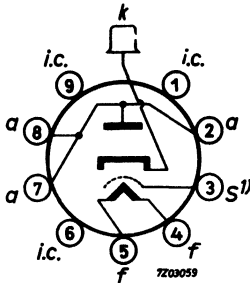

### CAPACITANCES

Anode to cathode

$C_{ak}$  13 pF

Cathode to heater

$C_{kf}$  3.7 pF

<sup>1)</sup> Insertion of a resistor of 300  $\Omega$  between pins 3 and 5 is recommended to improve the high-tension properties of the tube. If no resistor is used, pins 3 and 4 should be interconnected.

**TYPICAL CHARACTERISTICS**

|                                       |       |               |
|---------------------------------------|-------|---------------|
| Internal resistance ( $I_a = 440$ mA) | $R_i$ | 45.5 $\Omega$ |
|---------------------------------------|-------|---------------|

**LIMITING VALUES** (Design centre rating system)

|                                 |           |                           |
|---------------------------------|-----------|---------------------------|
| Anode dissipation               | $W_a$     | max. 11 W                 |
| Anode current, average          | $I_a$     | max. 440 mA               |
| peak                            | $I_{ap}$  | max. 800 mA               |
| Anode voltage, negative peak    | $-V_{ap}$ | max. 5600 V <sup>1)</sup> |
| negative peak,(absolute max.)   | $-V_{ap}$ | max. 7000 V <sup>1)</sup> |
| Cathode to heater voltage, peak | $V_{kfp}$ | max. 6300 V <sup>1)</sup> |

Series resistance heater chain

During operation, the external resistance between either heater pin of the PY500 and either mains terminal should be at least 100  $\Omega$  when  $V_f/\text{earth} = 220 V_{RMS}$   
50  $\Omega$  when  $V_f/\text{earth} = 110 V_{RMS}$

The hot heater resistances of other tubes in the heater chain can serve for this purpose.

<sup>1)</sup> Max. pulse duration 22% of a cycle, but max. 18  $\mu s$ .

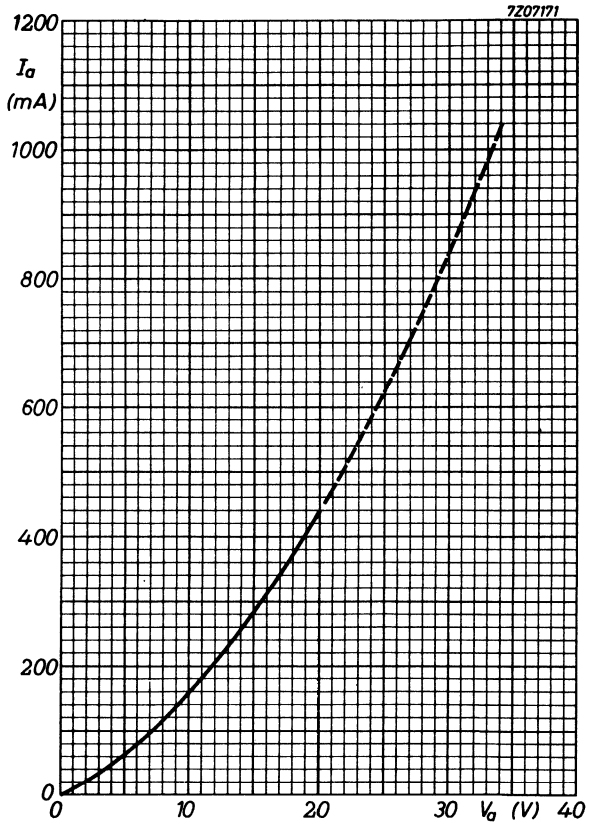



**BOOSTER DIODE**

Booster diode for timebase circuits of colour television receivers. The PY500A is unilaterally interchangeable with the PY500 in existing circuits. In new equipment designs the 300 Ω protection resistance between pins 3 and 5 can be deleted for the PY500A.

**HEATING:** Indirect by A. C. or D. C.; series supply

|                |       |     |    |
|----------------|-------|-----|----|
| Heater current | $I_f$ | 300 | mA |
| Heater voltage | $V_f$ | 42  | V  |

**MECHANICAL DATA**

Dimensions in mm

Base: Magnoval

Cap: Type 1

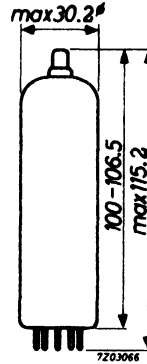
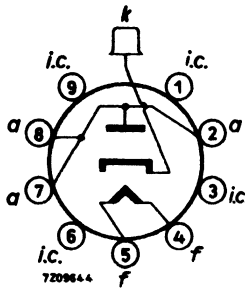

**CAPACITANCES**

Anode to cathode

$C_{ak}$  12.5 pF

Cathode to heater

$C_{kf}$  3.1 pF ←

**TYPICAL CHARACTERISTICS**

|  |       |               |
|--|-------|---------------|
| Internal resistance ( $I_a = 440 \text{ mA}$ ) | $R_i$ | 45.5 $\Omega$ |
|--|-------|---------------|

**LIMITING VALUES** (Design centre rating system)

|                                 |            |                           |
|---------------------------------|------------|---------------------------|
| Anode dissipation               | $W_a$      | max. 11 W                 |
| Anode current, average          | $I_a$      | max. 440 mA               |
| peak                            | $I_{a_p}$  | max. 1000 mA              |
| Anode voltage, negative peak    | $-V_{a_p}$ | max. 5600 V <sup>1)</sup> |
| negative peak (absolute max.)   | $-V_{a_p}$ | max. 7000 V <sup>1)</sup> |
| Cathode to heater voltage, peak | $V_{kfp}$  | max. 6300 V <sup>1)</sup> |

Series resistance heater chain

During operation, the external resistance between either heater pin of the PY500A and either mains terminal should be at least 100  $\Omega$  when  $V_f/\text{earth} = 220 \text{ V}_{\text{RMS}}$   
 50  $\Omega$  when  $V_f/\text{earth} = 110 \text{ V}_{\text{RMS}}$

The hot heater resistances of other tubes in the heater chain can serve for this purpose.

<sup>1)</sup> Max. pulse duration 22% of a cycle, but max. 18  $\mu\text{s}$ .



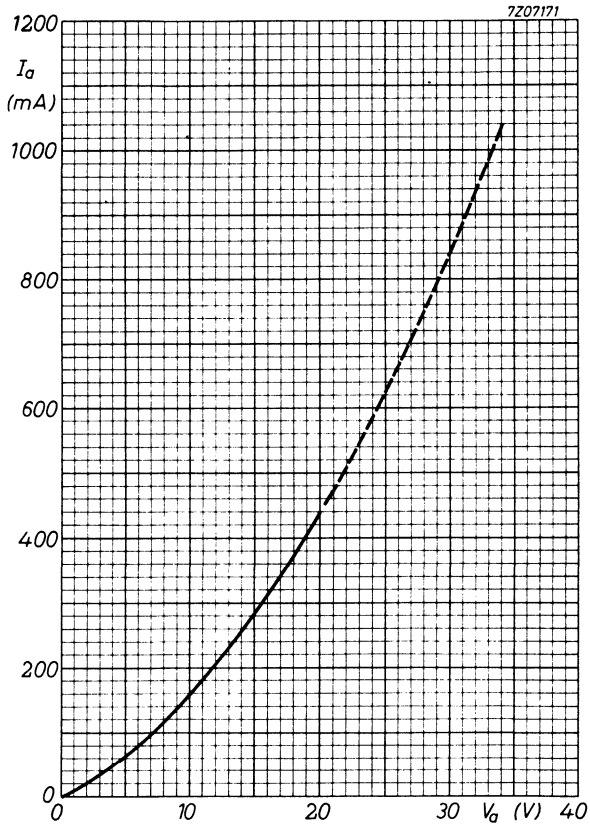



## TRIPLE DIODE-TRIODE

Triple diode-triode intended for F.M. and A.M. signal detection and A.F. signal amplification.

| QUICK REFERENCE DATA  |       |      |      |
|-----------------------|-------|------|------|
| <u>Triode section</u> |       |      |      |
| Anode current         | $I_a$ | 1.0  | mA   |
| Transconductance      | $S$   | 1.45 | mA/V |
| Amplification factor  | $\mu$ | 70   | -    |

**HEATING:** Indirect by A.C. or D.C.; series supply

|                |       |     |    |
|----------------|-------|-----|----|
| Heater current | $I_f$ | 100 | mA |
| Heater voltage | $V_f$ | 28  | V  |

### DIMENSIONS AND CONNECTIONS

Dimensions in mm

Base: Noval

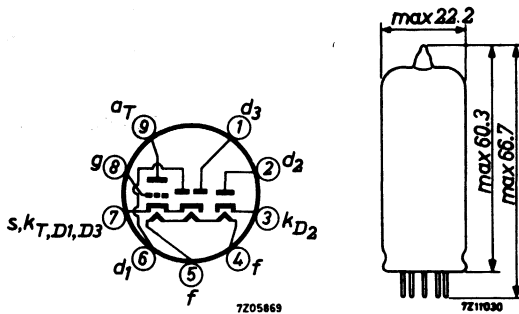

It is recommended to connect pin 5 to earth.

**CAPACITANCES**

Triode section

|                          |            |              |
|--------------------------|------------|--------------|
| Grid to all except anode | $C_{g(a)}$ | 1.9 pF       |
| Anode to all except grid | $C_{a(g)}$ | 1.4 pF       |
| Anode to grid            | $C_{ag}$   | 2.0 pF       |
| Grid to heater           | $C_{gf}$   | max. 0.04 pF |

Diode sections

|                                     |             |              |
|-------------------------------------|-------------|--------------|
| Diode No.1 to all                   | $C_{d1}$    | 0.8 pF       |
| Diode No.2 to all                   | $C_{d2}$    | 4.8 pF       |
| Diode No.3 to all                   | $C_{d3}$    | 4.8 pF       |
| Cathode (D <sub>2</sub> ) to all    | $C_{kD_2}$  | 5.0 pF       |
| Diode No.1 to heater                | $C_{d1f}$   | max. 0.25 pF |
| Diode No.3 to heater                | $C_{d3f}$   | max. 0.2 pF  |
| Cathode (D <sub>2</sub> ) to heater | $C_{kD_2f}$ | 2.5 pF       |

Between triode and diode sections

|                                    |             |               |
|------------------------------------|-------------|---------------|
| Anode to diode No.1                | $C_{ad1}$   | max. 0.12 pF  |
| Anode to diode No.3                | $C_{ad3}$   | max. 0.1 pF   |
| Anode to cathode (D <sub>2</sub> ) | $C_{akD_2}$ | max. 0.01 pF  |
| Grid to diode No.1                 | $C_{gd1}$   | max. 0.07 pF  |
| Grid to diode No.3                 | $C_{gd3}$   | max. 0.02 pF  |
| Grid to cathode (D <sub>2</sub> )  | $C_{gkD_2}$ | max. 0.005 pF |

**TYPICAL CHARACTERISTICS**

Triode section

|                      |       |      |       |      |            |
|----------------------|-------|------|-------|------|------------|
| Anode voltage        | $V_a$ | 100  | 170   | 200  | V          |
| Grid voltage         | $V_g$ | -1   | -1.85 | -2.3 | V          |
| Anode current        | $I_a$ | 0.8  | 1.0   | 1.0  | mA         |
| Transconductance     | S     | 1.45 | 1.45  | 1.40 | mA/V       |
| Amplification factor | $\mu$ | 70   | 70    | 70   | -          |
| Internal resistance  | $R_i$ | 48   | 48    | 50   | k $\Omega$ |

**OPERATING CHARACTERISTICS**

Triode section as R.C. coupled A.F. amplifier

Grid resistor  $R_g = 10 \text{ M}\Omega$

|                          |           |      |      |      |      |      |      |            |
|--------------------------|-----------|------|------|------|------|------|------|------------|
| Supply voltage           | $V_b$     | 200  | 200  | 200  | 170  | 170  | 170  | V          |
| Anode resistor           | $R_a$     | 220  | 100  | 47   | 220  | 100  | 47   | k $\Omega$ |
| Grid resistor next stage | $R_g'$    | 0.68 | 0.33 | 0.15 | 0.68 | 0.33 | 0.15 | M $\Omega$ |
| Anode current            | $I_a$     | 0.56 | 1.00 | 1.60 | 0.46 | 0.82 | 1.25 | mA         |
| Voltage gain             | $V_o/V_i$ | 53   | 44   | 34   | 51   | 42   | 32   | -          |

Distortion:

|  |           |     |     |     |     |     |     |   |
|--|-----------|-----|-----|-----|-----|-----|-----|---|
| at output voltage $V_o = 3 \text{ VRMS}$ | $d_{tot}$ | 0.3 | 0.4 | 0.5 | 0.4 | 0.5 | 0.6 | % |
| at output voltage $V_o = 5 \text{ VRMS}$ | $d_{tot}$ | 0.4 | 0.6 | 0.9 | 0.5 | 0.8 | 1.1 | % |
| at output voltage $V_o = 8 \text{ VRMS}$ | $d_{tot}$ | 0.9 | 1.0 | 1.5 | 1.1 | 1.3 | 2.0 | % |

|                          |           |      |      |      |            |
|--------------------------|-----------|------|------|------|------------|
| Supply voltage           | $V_b$     | 100  | 100  | 100  | V          |
| Anode resistor           | $R_a$     | 220  | 100  | 47   | k $\Omega$ |
| Grid resistor next stage | $R_g'$    | 0.68 | 0.33 | 0.15 | M $\Omega$ |
| Anode current            | $I_a$     | 0.21 | 0.35 | 0.52 | mA         |
| Voltage gain             | $V_o/V_i$ | 44   | 35   | 26   | -          |

Distortion:

|  |           |     |     |     |   |
|--|-----------|-----|-----|-----|---|
| at output voltage $V_o = 3 \text{ VRMS}$ | $d_{tot}$ | 1.0 | 1.3 | 2.0 | % |
| at output voltage $V_o = 5 \text{ VRMS}$ | $d_{tot}$ | 1.7 | 2.3 | 4.3 | % |

**TYPICAL CHARACTERISTICS**

Diode section

Internal resistance diode No. 1  
at diode voltage  $V_{d1} = +10$  V

$R_i D_1$  5 k $\Omega$

Internal resistance diode No. 2  
at diode voltage  $V_{d2} = +5$  V

$R_i D_2$  200  $\Omega$

Internal resistance diode No. 3  
at diode voltage  $V_{d3} = +5$  V

$R_i D_3$  200  $\Omega$

Ratio between  $R_i (D_2)$  and  $R_i (D_3)$

min. 0.67  
max. 1.5

Microphony Triode section

No special precautions against microphony are required in circuits where the input voltage is min. 10 mV for 50 mW output of the output tube at frequencies higher than 800 Hz.

At lower frequencies the sensitivity may be increased according to the figure below.

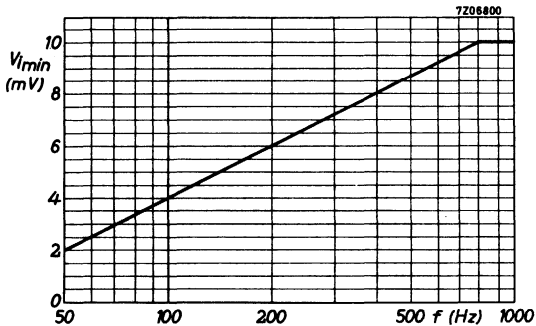

**LIMITING VALUES** (Design centre rating system)

Triode section

|                                    |          |                          |
|------------------------------------|----------|--------------------------|
| Anode voltage                      | $V_{a0}$ | max. 550 V               |
|                                    | $V_a$    | max. 250 V               |
| Anode dissipation                  | $W_a$    | max. 1 W                 |
| Cathode current                    | $I_k$    | max. 5 mA                |
| Grid resistor                      | $R_g$    | max. 3 M $\Omega$        |
| Grid resistor at grid current bias | $R_g$    | max. 22 M $\Omega$       |
| Cathode to heater voltage          | $V_{kf}$ | max. 150 V <sup>1)</sup> |

Diode sections

|                                   |            |            |
|-----------------------------------|------------|------------|
| Diode No.1 voltage, negative peak | $-V_{d1p}$ | max. 350 V |
| Diode No.2 voltage, negative peak | $-V_{d2p}$ | max. 350 V |
| Diode No.3 voltage, negative peak | $-V_{d3p}$ | max. 350 V |
| Diode No.1 current:               |            |            |
| D.C. component                    | $I_{d1}$   | max. 1 mA  |
| peak                              | $I_{d1p}$  | max. 6 mA  |
| Diode No.2 current:               |            |            |
| D.C. component                    | $I_{d2}$   | max. 10 mA |
| peak                              | $I_{d2p}$  | max. 75 mA |
| Diode No.3 current:               |            |            |
| D.C. component                    | $I_{d3}$   | max. 10 mA |
| peak                              | $I_{d3p}$  | max. 75 mA |

<sup>1)</sup> With regard to hum a max. AC heater to cathode voltage of 30 V<sub>RMS</sub> is recommended.





## DOUBLE DIODE-TRIODE

Double diode-triode. Triode intended for use as A. F. amplifier.

### QUICK REFERENCE DATA

| <u>Triode section</u> |       |           |
|-----------------------|-------|-----------|
| Anode current         | $I_a$ | 1.5 mA    |
| Transconductance      | $S$   | 1.65 mA/V |
| Amplification factor  | $\mu$ | 70 -      |

**HEATING:** Indirect by A. C. or D. C.; series supply

Heater current

$I_f$  100 mA

Heater voltage

$V_f$  14 V

### DIMENSIONS AND CONNECTIONS

Dimensions in mm

Base: Noval

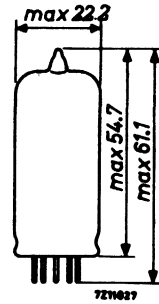
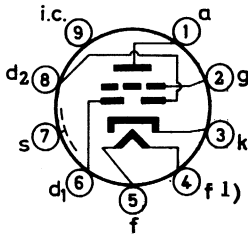

<sup>1)</sup> Earthed side of the heater circuit.

**CAPACITANCES**

Triode section

|                          |            |              |
|--------------------------|------------|--------------|
| Grid to all except anode | $C_{g(a)}$ | 2.3 pF       |
| Anode to all except grid | $C_{a(g)}$ | 2.3 pF       |
| Anode to grid            | $C_{ag}$   | 1.2 pF       |
| Grid to heater           | $C_{gf}$   | max. 0.05 pF |

Diode sections

|                            |            |              |
|----------------------------|------------|--------------|
| Diode No. 1 to all         | $C_{d1}$   | 0.9 pF       |
| Diode No. 2 to all         | $C_{d2}$   | 0.9 pF       |
| Diode No. 1 to diode No. 2 | $C_{d1d2}$ | max. 0.2 pF  |
| Diode No. 1 to heater      | $C_{d1f}$  | max. 0.25 pF |
| Diode No. 2 to heater      | $C_{d2f}$  | max. 0.05 pF |

Between triode and diode sections

|                      |           |               |
|----------------------|-----------|---------------|
| Diode No. 1 to grid  | $C_{d1g}$ | max. 0.007 pF |
| Diode No. 2 to grid  | $C_{d2g}$ | max. 0.007 pF |
| Diode No. 1 to anode | $C_{d1a}$ | max. 0.005 pF |
| Diode No. 2 to anode | $C_{d2a}$ | max. 0.01 pF  |

**TYPICAL CHARACTERISTICS OF THE TRIODE SECTION**

|                      |       |       |               |
|----------------------|-------|-------|---------------|
| Anode voltage        | $V_a$ | 170   | 100 V         |
| Grid voltage         | $V_g$ | -1.55 | -1.0 V        |
| Anode current        | $I_a$ | 1.5   | 0.8 mA        |
| Transconductance     | $S$   | 1.65  | 1.4 mA/V      |
| Amplification factor | $\mu$ | 70    | 70 -          |
| Internal resistance  | $R_i$ | 42    | 50 k $\Omega$ |

**OPERATING CHARACTERISTICS**

Triode section as A.F. amplifier, circuit Fig. 1

|                                  |           |      |      |      |      |           |
|----------------------------------|-----------|------|------|------|------|-----------|
| Supply voltage                   | $V_b$     | 170  | 100  | 170  | 100  | V         |
| Anode resistor                   | $R_a$     | 0.22 | 0.22 | 0.1  | 0.1  | $M\Omega$ |
| Cathode resistor                 | $R_k$     | 5.6  | 5.6  | 3.9  | 3.9  | $k\Omega$ |
| Grid resistor                    | $R_g$     | 1.0  | 1.0  | 1.0  | 1.0  | $M\Omega$ |
| Grid resistor next stage         | $R_g$     | 0.68 | 0.68 | 0.33 | 0.33 | $M\Omega$ |
| Anode current                    | $I_a$     | 0.28 | 0.18 | 0.45 | 0.28 | mA        |
| Voltage gain                     | $V_o/V_i$ | 44   | 41   | 37   | 34   |           |
| Distortion at:                   |           |      |      |      |      |           |
| output voltage $V_o = 3 V_{RMS}$ | $d_t$     | 1.1  | 1.4  | 1.1  | 2.0  | %         |
| output voltage $V_o = 5 V_{RMS}$ | $d_t$     | 1.3  | 1.9  | 1.7  | 3.5  | %         |
| output voltage $V_o = 8 V_{RMS}$ | $d_t$     | 1.85 | -    | 2.6  | -    | %         |
| Supply voltage                   | $V_b$     | 170  | 100  | 170  | 100  | V         |
| Anode resistor                   | $R_a$     | 0.22 | 0.22 | 0.1  | 0.1  | $M\Omega$ |
| Cathode resistor                 | $R_k$     | 0    | 0    | 0    | 0    | $\Omega$  |
| Grid resistor                    | $R_g$     | 22   | 22   | 22   | 22   | $M\Omega$ |
| Grid resistor next stage         | $R_g'$    | 0.68 | 0.68 | 0.33 | 0.33 | $M\Omega$ |
| Anode current                    | $I_a$     | 0.46 | 0.21 | 0.82 | 0.35 | mA        |
| Voltage gain                     | $V_o/V_i$ | 48   | 41   | 42   | 35   |           |
| Distortion at                    |           |      |      |      |      |           |
| output voltage $V_o = 3 V_{RMS}$ | $d_t$     | 0.95 | 1.45 | 0.75 | 1.6  | %         |
| output voltage $V_o = 5 V_{RMS}$ | $d_t$     | 1.1  | 2.0  | 1.0  | 2.8  | %         |
| output voltage $V_o = 8 V_{RMS}$ | $d_t$     | 1.3  | -    | 1.2  | -    | %         |

**OPERATING CHARACTERISTICS** (continued)

Microphony

No special precautions against microphony are required in circuits where the input voltage is min. 10 mV for 50 mW output of the output tube.

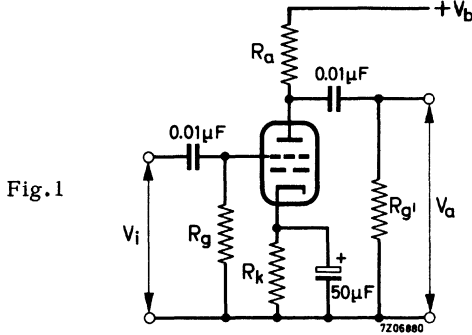

Fig. 1

**LIMITING VALUES** (Design centre rating system)

Triode section

|                           |          |      |       |
|---------------------------|----------|------|-------|
| Anode voltage             | $V_{a0}$ | max. | 550 V |
|                           | $V_a$    | max. | 250 V |
| Anode dissipation         | $W_a$    | max. | 0.5 W |
| Cathode current           | $I_k$    | max. | 5 mA  |
| Grid resistor             | $R_g$    | max. | 3 MΩ  |
| Cathode to heater voltage | $V_{kf}$ | max. | 100 V |

Diode sections (each diode)

|                              |           |      |        |
|------------------------------|-----------|------|--------|
| Diode voltage, negative peak | $-V_{dp}$ | max. | 350 V  |
| Diode current:               |           |      |        |
| average                      | $I_d$     | max. | 0.8 mA |
| peak                         | $I_{dp}$  | max. | 5 mA   |
| Cathode to heater voltage    | $V_{kf}$  | max. | 100 V  |

## DOUBLE DIODE-PENTODE

Double diode-pentode. Pentode intended for use as R.F. or I.F. amplifier.

| <b>QUICK REFERENCE DATA</b> |                |     |      |
|-----------------------------|----------------|-----|------|
| <u>Pentode section</u>      |                |     |      |
| Variable transconductance   |                |     |      |
| Anode current               | $I_a$          | 11  | mA   |
| Transconductance            | $S$            | 4.5 | mA/V |
| Amplification factor        | $\mu_{g_2g_1}$ | 20  | -    |

**HEATING:** Indirect by A.C. or D.C.; series supply

|                |       |     |    |
|----------------|-------|-----|----|
| Heater current | $I_f$ | 100 | mA |
| Heater voltage | $V_f$ | 19  | V  |

### DIMENSIONS AND CONNECTIONS

Dimensions in mm

Base: Noval

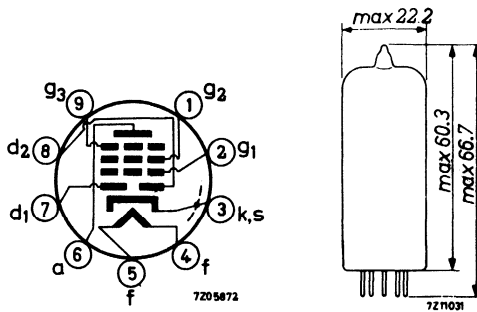

**CAPACITANCES**Pentode section

|                               |              |                |
|-------------------------------|--------------|----------------|
| Anode to all except grid No.1 | $C_{a(g_1)}$ | 5.2 pF         |
| Grid No.1 to all except anode | $C_{g_1(a)}$ | 5.0 pF         |
| Anode to grid No.1            | $C_{ag_1}$   | max. 0.0025 pF |
| Grid No.1 to heater           | $C_{g_1f}$   | max. 0.05 pF   |

Diode sections

|                          |              |               |
|--------------------------|--------------|---------------|
| Diode No.1 to all        | $C_{d_1}$    | 2.5 pF        |
| Diode No.2 to all        | $C_{d_2}$    | 2.5 pF        |
| Diode No.1 to diode No.2 | $C_{d_1d_2}$ | max. 0.25 pF  |
| Diode No.1 to heater     | $C_{d_1f}$   | max. 0.015 pF |
| Diode No.2 to heater     | $C_{d_2f}$   | max. 0.003 pF |

Between pentode and diode sections

|                         |              |                |
|-------------------------|--------------|----------------|
| Diode No.1 to grid No.1 | $C_{d_1g_1}$ | max. 0.0008 pF |
| Diode No.2 to grid No.1 | $C_{d_2g_1}$ | max. 0.001 pF  |
| Diode No.1 to anode     | $C_{d_1a}$   | max. 0.15 pF   |
| Diode No.2 to anode     | $C_{d_2a}$   | max. 0.025 pF  |

**TYPICAL CHARACTERISTICS**

Pentode section

|                      |                |      |                  |     |            |
|----------------------|----------------|------|------------------|-----|------------|
| Anode voltage        | $V_a$          | 200  | 170              | 100 | V          |
| Grid No.2 voltage    | $V_{g_2}$      | 100  | 100              | 100 | V          |
| Grid No.3 voltage    | $V_{g_3}$      | 0    | 0                | 0   | V          |
| Grid No.1 voltage    | $V_{g_1}$      | -1.5 | -1 <sup>1)</sup> | -2  | V          |
| Anode current        | $I_a$          | 11   | 12               | 8.5 | mA         |
| Grid No.2 current    | $I_{g_2}$      | 3.3  | 4                | 2.8 | mA         |
| Transconductance     | S              | 4.5  | 5                | 3.5 | mA/V       |
| Amplification factor | $\mu_{g_2g_1}$ | 20   | 20               | 20  | -          |
| Internal resistance  | $R_i$          | 0.6  | 0.4              | 0.3 | M $\Omega$ |

**OPERATING CHARACTERISTICS**

Pentode section as R.F. or I.F. amplifier

|                     |           |      |      |            |      |            |
|---------------------|-----------|------|------|------------|------|------------|
| Supply voltage      | $V_b$     | 200  | 100  | V          |      |            |
| Anode resistor      | $R_a$     | 0    | 0    | $\Omega$   |      |            |
| Grid No.3 voltage   | $V_{g_3}$ | 0    | 0    | V          |      |            |
| Grid No.2 resistor  | $R_{g_2}$ | 30   | 0    | k $\Omega$ |      |            |
| Grid No.1 voltage   | $V_{g_1}$ | -1.5 | -20  | -2         | -10  | V          |
| Anode current       | $I_a$     | 11   | -    | 8.5        | -    | mA         |
| Grid No.2 current   | $I_{g_2}$ | 3.3  | -    | 2.8        | -    | mA         |
| Transconductance    | S         | 4.5  | 0.12 | 3.5        | 0.11 | mA/V       |
| Internal resistance | $R_i$     | 0.6  | -    | 0.3        | -    | M $\Omega$ |

1) To avoid grid No.1 current the negative grid No.1 voltage should be min. 1.5 V

**LIMITING VALUES** (Design centre rating system)

Pentode section

|                                  |           |      |      |           |
|----------------------------------|-----------|------|------|-----------|
| Anode voltage                    | $V_{a0}$  | max. | 550  | V         |
|                                  | $V_a$     | max. | 250  | V         |
| Anode dissipation                | $W_a$     | max. | 2.25 | W         |
| Grid No.2 voltage                | $V_{g20}$ | max. | 550  | V         |
| Grid No.2 voltage                |           |      |      |           |
| at anode current $I_a$ max. 4 mA | $V_{g2}$  | max. | 250  | V         |
| at anode current $I_a$ min. 8 mA | $V_{g2}$  | max. | 125  | V         |
| Grid No.2 dissipation            | $W_{g2}$  | max. | 0.45 | W         |
| Cathode current                  | $I_k$     | max. | 16.5 | mA        |
| Grid No.1 resistor               | $R_{g1}$  | max. | 3    | $M\Omega$ |
| Grid No.3 resistor               | $R_{g3}$  | max. | 10   | $k\Omega$ |
| Cathode to heater voltage        | $V_{kf}$  | max. | 100  | V         |

Diode sections (each diode)

|                              |           |      |     |    |
|------------------------------|-----------|------|-----|----|
| Diode voltage, negative peak | $-V_{dp}$ | max. | 200 | V  |
| Diode current; average       | $I_d$     | max. | 0.8 | mA |
| peak                         | $I_{dp}$  | max. | 5   | mA |
| Cathode to heater voltage    | $V_{kf}$  | max. | 100 | V  |



**R.F. DOUBLE TRIODE**

Double triode intended for use as R.F. amplifier and self oscillating mixer.

| QUICK REFERENCE DATA |       |     |      |
|----------------------|-------|-----|------|
| Anode current        | $I_a$ | 10  | mA   |
| Transconductance     | $S$   | 6.7 | mA/V |
| Amplification factor | $\mu$ | 48  | -    |

**HEATING:** Indirect by A.C. or D.C.; series supply

|                |       |     |    |
|----------------|-------|-----|----|
| Heater current | $I_f$ | 100 | mA |
| Heater voltage | $V_f$ | 26  | V  |

**DIMENSIONS AND CONNECTIONS**

Dimensions in mm

Base: Noval

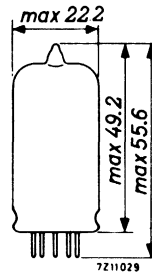
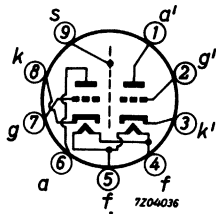

## CAPACITANCES (each unit unless otherwise specified)

|  |             |            |    |
|--|-------------|------------|----|
| Anode to grid  | $C_{ag}$    | 1.5        | pF |
| Anode to cathode   | $C_{ak}$    | 0.18       | pF |
| Anode to cathode + heater + screen   | $C_{a/kfs}$ | 1.2        | pF |
| Grid to cathode + heater + screen  | $C_{g/kfs}$ | 3.1        | pF |
| Anode to cathode + heater + screen<br>(measured with external screen of 22.5 mm diam.) | $C_{a/kfs}$ | 1.8        | pF |
| Anode to anode other unit  | $C_{aa'}$   | max. 0.04  | pF |
| Anode to anode other unit<br>(measured with external screen of 22.5 mm diam.)          | $C_{aa'}$   | max. 0.008 | pF |
| Grid to grid other unit  | $C_{gg'}$   | max. 0.003 | pF |
| Anode to grid other unit   | $C_{ag'}$   | max. 0.008 | pF |
| Anode to grid other unit   | $C_{a'g}$   | max. 0.008 | pF |
| Anode to cathode other unit  | $C_{ak'}$   | max. 0.008 | pF |
| Grid to cathode other unit   | $C_{gk'}$   | max. 0.003 | pF |
| Anode to cathode other unit  | $C_{a'k}$   | max. 0.008 | pF |
| Grid to cathode other unit   | $C_{g'k}$   | max. 0.003 | pF |

## TYPICAL CHARACTERISTICS (each unit)

|                      |       |                    |       |      |      |
|----------------------|-------|--------------------|-------|------|------|
| Anode voltage        | $V_a$ | 100                | 170   | 200  | V    |
| Grid voltage         | $V_g$ | -1.2 <sup>1)</sup> | -1.75 | -2.4 | V    |
| Anode current        | $I_a$ | 4.5                | 10    | 10   | mA   |
| Transconductance     | $S$   | 4.8                | 6.7   | 6    | mA/V |
| Amplification factor | $\mu$ | 46                 | 48    | 46   | -    |

<sup>1)</sup> In this case grid current may occur. If this is not permissible, a condition with a bias of -1.5 V should be chosen.

**OPERATING CHARACTERISTICS**

As R.F. amplifier (unit a, g, k)

|                                     |          |      |      |      |           |
|-------------------------------------|----------|------|------|------|-----------|
| Supply voltage                      | $V_b$    | 170  | 170  | 100  | V         |
| Anode resistor                      | $R_a$    | 1.3  | 1.5  | 1.5  | $k\Omega$ |
| Anode voltage                       | $V_a$    | 161  | 155  | 91   | V         |
| Cathode resistor                    | $R_k$    | 330  | 150  | 138  | $\Omega$  |
| Grid voltage                        | $V_g$    | -2.2 | -1.5 | -0.8 | V         |
| Anode current                       | $I_a$    | 6.6  | 9.8  | 5.7  | mA        |
| Transconductance                    | S        | 5.1  | 6.7  | 5.9  | mA/V      |
| Internal resistance                 | $R_i$    | 8.5  | 7    | 8    | $k\Omega$ |
| Grid input resistance (f = 100 MHz) | $r_g$    | 5.2  | 3.8  | 2.8  | $k\Omega$ |
| Equivalent noise resistance         | $R_{eq}$ | 0.82 | 0.55 | 0.61 | $k\Omega$ |

As self oscillating additive mixer (each unit)

|                                     |            |     |     |     |           |
|-------------------------------------|------------|-----|-----|-----|-----------|
| Anode supply voltage                | $V_b$      | 100 | 170 | 200 | V         |
| Anode resistor                      | $R_a$      | 4.7 | 4.7 | 8.2 | $k\Omega$ |
| Grid resistor                       | $R_g$      | 1   | 1   | 1   | $M\Omega$ |
| Oscillator voltage                  | $V_{osc.}$ | 1.8 | 2.8 | 2.8 | $V_{RMS}$ |
| Anode current                       | $I_a$      | 2.7 | 5.5 | 6   | mA        |
| Conversion conductance              | $S_c$      | 2.2 | 2.8 | 2.9 | mA/V      |
| Internal resistance                 | $R_i$      | 19  | 15  | 14  | $k\Omega$ |
| Grid input resistance (f = 100 MHz) | $r_g$      |     | 15  |     | $k\Omega$ |

**LIMITING VALUES** (each unit) (Design centre rating system)

|                           |            |      |     |           |
|---------------------------|------------|------|-----|-----------|
| Anode voltage             | $V_{a0}$   | max. | 550 | V         |
|                           | $V_a$      | max. | 250 | V         |
| Anode dissipation         | $W_a$      | max. | 2.5 | W         |
|                           | $W_a+W_a'$ | max. | 4.5 | W         |
| Cathode current           | $I_k$      | max. | 15  | mA        |
| Cathode to heater voltage | $V_{kf}$   | max. | 90  | V         |
| Grid voltage (negative)   | $-V_g$     | max. | 100 | V         |
| Grid resistor             | $R_g$      | max. | 1   | $M\Omega$ |

For curves please refer to type PCC85



## TRIODE-HEPTODE

Triode-heptode. Heptode section intended for use as mixer R.F. - or I.F. amplifier. Triode section intended for use as oscillator in A.M./F.M. receivers.

| QUICK REFERENCE DATA   |                |      |      |
|------------------------|----------------|------|------|
| <u>Triode section</u>  |                |      |      |
| Anode current          | $I_a$          | 13.5 | mA   |
| Transconductance       | $S$            | 3.7  | mA/V |
| Amplification factor   | $\mu$          | 22   | -    |
| <u>Heptode section</u> |                |      |      |
| Anode current          | $I_a$          | 9.8  | mA   |
| Transconductance       | $S$            | 4.3  | mA/V |
| Amplification factor   | $\mu_{g_2g_1}$ | 25   | -    |

**HEATING:** Indirect by A.C. or D.C.; series supply

|                |       |     |    |
|----------------|-------|-----|----|
| Heater current | $I_f$ | 100 | mA |
| Heater voltage | $V_f$ | 19  | V  |

### DIMENSIONS AND CONNECTIONS

Dimensions in mm

Base: Noval

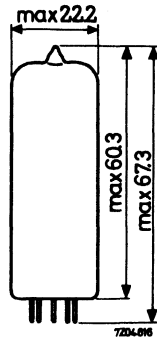
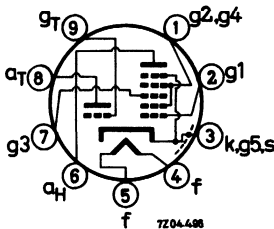

**CAPACITANCES**

Triode section

|                          |            |              |
|--------------------------|------------|--------------|
| Grid to all except anode | $C_{g(a)}$ | 2.6 pF       |
| Anode to all except grid | $C_{a(g)}$ | 2.1 pF       |
| Anode to grid            | $C_{ag}$   | 1.0 pF       |
| Grid to heater           | $C_{gf}$   | max. 0.02 pF |

Heptode section

|                               |              |              |
|-------------------------------|--------------|--------------|
| Grid No.1 to all except anode | $C_{g_1(a)}$ | 4.8 pF       |
| Anode to all except grid No.1 | $C_{a(g_1)}$ | 7.9 pF       |
| Anode to grid No.1            | $C_{ag_1}$   | max.0.006 pF |
| Grid No.1 to heater           | $C_{g_1f}$   | max. 0.17 pF |
| Grid No.3 to all              | $C_{g_3}$    | 6 pF         |
| Grid No.1 to grid No.3        | $C_{g_1g_3}$ | max. 0.3 pF  |
| Grid No.3 to heater           | $C_{g_3f}$   | max. 0.06 pF |

Between heptode and triode sections

|   |                  |              |
|---|------------------|--------------|
| Anode heptode to anode triode                   | $C_{aHaT}$       | 0.20 pF      |
| Anode heptode to grid triode                    | $C_{aHgT}$       | max. 0.09 pF |
| Grid No.1 heptode to anode triode               | $C_{g_1HaT}$     | max. 0.06 pF |
| Grid No.1 heptode to grid triode                | $C_{g_1HgT}$     | max. 0.17 pF |
| Grid No.1 heptode to grid triode<br>+ grid No.3 | $C_{g_1H/gTg_3}$ | max. 0.45 pF |
| Anode heptode to grid triode<br>+ grid No.3     | $C_{aH/gTg_3}$   | max. 0.35 pF |

## TYPICAL CHARACTERISTICS

Triode section

|                      |       |          |
|----------------------|-------|----------|
| Anode voltage        | $V_a$ | 100 V    |
| Grid voltage         | $V_g$ | 0 V      |
| Anode current        | $I_a$ | 13.5 mA  |
| Transconductance     | S     | 3.7 mA/V |
| Amplification factor | $\mu$ | 22 -     |

Heptode section

|                          |                |             |
|--------------------------|----------------|-------------|
| Anode voltage            | $V_a$          | 160 V       |
| Grid No.3 voltage        | $V_{g3}$       | 0 V         |
| Grids No.2 and 4 voltage | $V_{g_{2+4}}$  | 90 V        |
| Grid No.1 current        | $I_{g1}$       | 0.5 $\mu$ A |
| Grid No.1 voltage        | $V_{g1}$       | -0.5 V      |
| Anode current            | $I_a$          | 9.8 mA      |
| Grids No.2 and 4 current | $I_{g_{2+4}}$  | 6.1 mA      |
| Transconductance         | S              | 4.3 mA/V    |
| Amplification factor     | $\mu_{g_2g_1}$ | 25 -        |

**OPERATING CHARACTERISTICS**

Heptode section as mixer

|                                  |                 |      |       |      |       |             |                       |
|----------------------------------|-----------------|------|-------|------|-------|-------------|-----------------------|
| Supply voltage                   | $V_b$           | 100  |       | 170  |       | 200         | V                     |
| Anode resistor                   | $R_a$           | 0    |       | 0    |       | 0           | $\Omega$              |
| Grids No.2 and 4 resistor        | $R_{g_{2+4}}$   | 10   |       | 10   |       | 10          | $k\Omega$             |
| Grid triode + grid No.3 resistor | $R_{g_{T+g_3}}$ | 47   |       | 47   |       | 47          | $k\Omega$             |
| Grid triode + grid No.3 current  | $I_{g_{T+g_3}}$ | 115  |       | 200  |       | 230 $\mu A$ |                       |
| Grid No.1 current                | $I_{g_1}$       | 0.5  | -     | 0.5  | -     | 0.5         | $\mu A$ <sup>1)</sup> |
| Grid No.1 voltage                | $V_{g_1}$       | -0.5 | -12   | -0.5 | -19   | -0.5        | -22 V                 |
| Anode voltage                    | $V_a$           | 100  | -     | 170  | -     | 200         | - V                   |
| Grids No.2 and 4 voltage         | $V_{g_{2+4}}$   | 56   | -     | 88   | -     | 100         | - V                   |
| Anode current                    | $I_a$           | 2.0  | -     | 3.3  | -     | 4.1         | - mA                  |
| Grids No.2 and 4 current         | $I_{g_{2+4}}$   | 4.4  | -     | 8.2  | -     | 10          | - mA                  |
| Conversion conductance           | $S_c$           | 850  | 8.5   | 1100 | 11    | 1200        | 12 $\mu A/V$          |
| Internal resistance              | $R_i$           | 0.75 | min.3 | 0.8  | min.3 | 0.85        | min.3 $M\Omega$       |
| Equivalent noise resistance      | $R_{eq}$        | 33   | -     | 30   | -     | 32          | - $k\Omega$           |

<sup>1)</sup> Grid current bias obtained with  $R_{g_1} = 1 M\Omega$  and with zero volts a.g.c. voltage; resulting grid No.1 voltage: -0.5 V.



**OPERATING CHARACTERISTICS (continued)**

Heptode section as R.F. or I.F. amplifier

|                             |                |             |            |             |                         |      |     |           |
|-----------------------------|----------------|-------------|------------|-------------|-------------------------|------|-----|-----------|
| Supply voltage              | $V_b$          | 100         | 170        | 200         | V                       |      |     |           |
| Anode resistor              | $R_a$          | 0           | 0          | 3.9         | $k\Omega$               |      |     |           |
| Grids No.2 and 4 resistor   | $R_{g_{2+4}}$  | 18          | 18         | 18          | $k\Omega$               |      |     |           |
| Grid No.3 voltage           | $V_{g_3}$      | 0           | 0          | 0           | V                       |      |     |           |
| Grid No.1 current           | $I_{g_1}$      | 0.5         | - 0.5      | - 0.5       | - $\mu A$ <sup>1)</sup> |      |     |           |
| Grid No.1 voltage           | $V_{g_1}$      | -0.5        | -15.7      | -0.5        | -26                     | -0.5 | -30 | V         |
| Anode voltage               | $V_a$          | 100         | -          | 170         | -                       | 162  | -   | V         |
| Grids No.2 and 4 voltage    | $V_{g_{2+4}}$  | 52          | -          | 80          | -                       | 90   | -   | V         |
| Anode current               | $I_a$          | 4.1         | -          | 8.0         | -                       | 9.8  | -   | mA        |
| Grids No.2 and 4 current    | $I_{g_{2+4}}$  | 2.7         | -          | 5.0         | -                       | 6.1  | -   | mA        |
| Transconductance            | $S$            | 2900        | 29         | 3900        | 39                      | 4300 | 43  | $\mu A/V$ |
| Internal resistance         | $R_i$          | 0.45 min.10 | 0.4 min.10 | 0.35 min.10 |                         |      |     | $M\Omega$ |
| Amplification factor        | $\mu_{g_2g_1}$ | 24          | -          | 25          | -                       | 25   | -   | -         |
| Equivalent noise resistance | $R_{eq}$       | 4.0         | -          | 4.0         | -                       | 4.3  | -   | $k\Omega$ |

Triode section as oscillator

|                                  |               |      |      |      |           |
|----------------------------------|---------------|------|------|------|-----------|
| Supply voltage                   | $V_b$         | 100  | 170  | 200  | V         |
| Anode resistor                   | $R_a$         | 15   | 15   | 15   | $k\Omega$ |
| Grid triode + grid No.3 resistor | $R_{g_T+g_3}$ | 47   | 47   | 47   | $k\Omega$ |
| Grid triode + grid No.3 current  | $I_{g_T+g_3}$ | 115  | 200  | 230  | $\mu A$   |
| Anode current                    | $I_a$         | 2.5  | 4.5  | 5.4  | mA        |
| Effective transconductance       | $S_{eff}$     | 0.58 | 0.65 | 0.65 | mA/V      |

<sup>1)</sup> Grid current bias obtained with  $R_{g_1} = 1 M\Omega$  and with zero volts a.g.c. voltage; resulting grid No.1 voltage: -0.5 V.

**LIMITING VALUES** (Design centre rating system)

Heptode section

|  |                 |                   |
|--|-----------------|-------------------|
| Anode voltage  | $V_{a_0}$       | max. 550 V        |
|  | $V_a$           | max. 250 V        |
| Anode dissipation  | $W_a$           | max. 1.8 W        |
| Grids No.2 and 4 voltage   | $V_{g_{2+4_0}}$ | max. 550 V        |
|  | $V_{g_{2+4}}$   | max. 125 V        |
| Grids No.2 and 4 voltage ( $I_a$ max. 1 mA)                          | $V_{g_{2+4}}$   | max. 250 V        |
| Grids No.2 and 4 dissipation   | $W_{g_{2+4}}$   | max. 1 W          |
| Cathode current  | $I_k$           | max. 18 mA        |
| Grid No.1 resistor   | $R_{g_1}$       | max. 3 $M\Omega$  |
| Grid No.3 resistor   | $R_{g_3}$       | max. 20 $k\Omega$ |
| Grid No.3 resistor<br>grid No.3 directly connected<br>to grid triode | $R_{g_3}$       | max. 3 $M\Omega$  |
| Cathode to heater voltage  | $V_{kf}$        | max. 100 V        |

Triode section

|                           |           |                  |
|---------------------------|-----------|------------------|
| Anode voltage             | $V_{a_0}$ | max. 550 V       |
|                           | $V_a$     | max. 250 V       |
| Anode dissipation         | $W_a$     | max. 0.8 W       |
| Cathode current           | $I_k$     | max. 6.5 mA      |
| Grid resistor             | $R_g$     | max. 3 $M\Omega$ |
| Cathode to heater voltage | $V_{kf}$  | max. 100 V       |

## TRIODE-OUTPUT PENTODE

The triode section is intended for use as A. F. amplifier.

The pentode section is intended for use as A. F. power amplifier.

| QUICK REFERENCE DATA   |                |     |      |
|------------------------|----------------|-----|------|
| <u>Triode section</u>  |                |     |      |
| Anode current          | $I_a$          | 3.5 | mA   |
| Transconductance       | S              | 2.2 | mA/V |
| Amplification factor   | $\mu$          | 70  | -    |
| <u>Pentode section</u> |                |     |      |
| Anode current          | $I_a$          | 41  | mA   |
| Transconductance       | S              | 7.5 | mA/V |
| Amplification factor   | $\mu_{g_2g_1}$ | 9.5 | -    |
| Output power           | $W_o$          | 3.3 | W    |

**HEATING:** Indirect by A. C. or D. C.; series supply

|                |       |     |    |
|----------------|-------|-----|----|
| Heater current | $I_f$ | 100 | mA |
| Heater voltage | $V_f$ | 50  | V  |

### DIMENSIONS AND CONNECTIONS

Dimensions in mm

Base: Noval

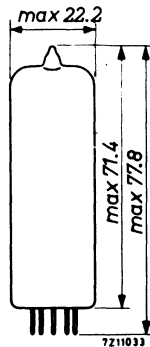
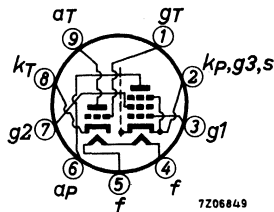

**CAPACITANCES**

Triode section

|                          |            |              |
|--------------------------|------------|--------------|
| Anode to all except grid | $C_{a(g)}$ | 4.3 pF       |
| Grid to all except anode | $C_{g(a)}$ | 2.7 pF       |
| Anode to grid            | $C_{ag}$   | 4.4 pF       |
| Grid to heater           | $C_{gf}$   | max. 0.02 pF |

Pentode section

|                                |              |             |
|--------------------------------|--------------|-------------|
| Anode to all except grid No. 1 | $C_{a(g_1)}$ | 8.0 pF      |
| Grid No. 1 to all except anode | $C_{g_1(a)}$ | 9.3 pF      |
| Anode to grid No. 1            | $C_{ag_1}$   | max. 0.3 pF |
| Grid No. 1 to heater           | $C_{g_1f}$   | max. 0.3 pF |

Between triode and pentode sections

|                                    |              |               |
|------------------------------------|--------------|---------------|
| Anode triode to grid No. 1 pentode | $C_{aTg_1P}$ | max. 0.02 pF  |
| Grid triode to anode pentode       | $C_{gTap}$   | max. 0.02 pF  |
| Grid triode to grid No. 1 pentode  | $C_{gTg_1P}$ | max. 0.025 pF |
| Anode triode to anode pentode      | $C_{aTap}$   | max. 0.25 pF  |

**TYPICAL CHARACTERISTICS**

Triode section

|                      |       |          |
|----------------------|-------|----------|
| Anode voltage        | $V_a$ | 100 V    |
| Grid voltage         | $V_g$ | 0 V      |
| Anode current        | $I_a$ | 3.5 mA   |
| Transconductance     | $S$   | 2.2 mA/V |
| Amplification factor | $\mu$ | 70 -     |

Pentode section

|                      |                |               |
|----------------------|----------------|---------------|
| Anode voltage        | $V_a$          | 170 V         |
| Grid No. 2 voltage   | $V_{g_2}$      | 170 V         |
| Grid No. 1 voltage   | $V_{g_1}$      | -11.5 V       |
| Anode current        | $I_a$          | 41 mA         |
| Grid No. 2 current   | $I_{g_2}$      | 9 mA          |
| Transconductance     | $S$            | 7.5 mA/V      |
| Amplification factor | $\mu_{g_2g_1}$ | 9.5 -         |
| Internal resistance  | $R_i$          | 16 k $\Omega$ |

**OPERATING CHARACTERISTICS**

Triode section as A. F. amplifier

|                             |                         |                   |                   |                   |                   |           |
|-----------------------------|-------------------------|-------------------|-------------------|-------------------|-------------------|-----------|
| A) Signal source resistance | $R_S$                   | 0.22              |                   |                   |                   | $M\Omega$ |
| Grid resistor               | $R_g$                   | 3                 |                   |                   |                   | $M\Omega$ |
| Grid resistor of next stage | $R_g'$                  | 0.68              |                   |                   |                   | $M\Omega$ |
| Supply voltage              | $V_b$                   | 170               |                   | 100               |                   | V         |
| Cathode resistor            | $R_k$                   | 2.7               |                   | 2.7               |                   | $k\Omega$ |
| Anode resistor              | $R_a$                   | 220               |                   | 220               |                   | $k\Omega$ |
| Anode current               | $I_a$                   | 0.43              |                   | 0.23              |                   | mA        |
| Voltage gain                | $V_o/V_i$ <sup>1)</sup> | 51                |                   | 47                |                   | -         |
| Max. output voltage         | $V_{o\max}$             | 25                |                   | 15                |                   | $V_{RMS}$ |
| Distortion                  | $d_{tot}$ <sup>2)</sup> | 2.3               |                   | 4.0               |                   | %         |
| B) Signal source resistance | $R_S$                   | 0.22              |                   |                   |                   | $M\Omega$ |
| Grid resistor               | $R_g$                   | 22                |                   |                   |                   | $M\Omega$ |
| Grid resistor of next stage | $R_g$                   | 0.68              |                   |                   |                   | $M\Omega$ |
| Supply voltage              | $V_b$                   | 170               | 170               | 100               | 100               | V         |
| Cathode resistor            | $R_k$                   | 0                 | 0                 | 0                 | 0                 | $\Omega$  |
| Anode resistor              | $R_a$                   | 100               | 220               | 100               | 220               | $k\Omega$ |
| Anode current               | $I_a$                   | 0.86              | 0.50              | 0.37              | 0.22              | mA        |
| Voltage gain                | $V_o/V_i$ <sup>1)</sup> | 49                | 53                | 42                | 46                | -         |
| Max. output voltage         | $V_{o\max}$             | 19                | 20                | 8                 | 9                 | $V_{RMS}$ |
| Distortion                  | $d_{tot}$               | 1.4 <sup>3)</sup> | 1.4 <sup>3)</sup> | 1.3 <sup>2)</sup> | 1.5 <sup>2)</sup> | %         |

Microphony and hum

The triode section can be used without special precautions against microphony and hum in circuits in which an input voltage of minimum  $10\text{ mV}_{RMS}$  is required for an output of  $50\text{ mW}$  of the output stage,  $Z_g (f = 50\text{ Hz}) = 0.25\text{ M}\Omega$  and without A. C. voltage between pin 4 and cathode.

<sup>1)</sup> Measured at small input voltage.

<sup>2)</sup> At lower output voltages the distortion is proportionally lower.

<sup>3)</sup> At lower output voltages down to  $5\text{ V}_{RMS}$  the distortion is approximately constant. At values below  $5\text{ V}_{RMS}$  the distortion is approximately proportional to  $V_o$ .

**OPERATING CHARACTERISTICS**

Pentode section

Class A (Measured with  $V_k$  constant)

|                            |                    |            |            |           |
|----------------------------|--------------------|------------|------------|-----------|
| Supply voltage             | $V_{ba} = V_{bg2}$ | 100        | 170        | V         |
| Cathode resistor           | $R_k$              | 170        | 200        | $\Omega$  |
| Load resistance            | $R_{a\sim}$        | 3.0        | 3.25       | $k\Omega$ |
| Grid No. 1 driving voltage | $V_i$              | 0 0.7 3.75 | 0 0.61 5.9 | $V_{RMS}$ |
| Anode current              | $I_a$              | 26 - 27    | 42 - 44    | mA        |
| Grid No. 2 current         | $I_{g2}$           | 5.8 - 8.6  | 9.2 - 15.5 | mA        |
| Output power               | $W_o$              | 0 0.05 1.0 | 0 0.05 3.2 | W         |
| Distortion                 | $d_{tot}$          | - - 10     | - - 10     | %         |

|  |                    |            |           |
|--|--------------------|------------|-----------|
| Supply voltage                             | $V_{ba} = V_{bg2}$ | 200        | V         |
| Grid No. 2 series resistor (non-decoupled) | $R_{g2}$           | 470        | $\Omega$  |
| Cathode resistor                           | $R_k$              | 330        | $\Omega$  |
| Load resistance                            | $R_{a\sim}$        | 4.5        | $k\Omega$ |
| Grid No. 1 driving voltage                 | $V_i$              | 0 0.66 6.7 | $V_{RMS}$ |
| Anode current                              | $I_a$              | 35 - 37    | mA        |
| Grid No. 2 current                         | $I_{g2}$           | 7.8 - 13.3 | mA        |
| Output power                               | $W_o$              | 0 0.05 3.3 | W         |
| Distortion                                 | $d_{tot}$          | - - 10     | %         |

**LIMITING VALUES** (Design centre rating system)

Triode section

|                           |          |                     |
|---------------------------|----------|---------------------|
| Anode voltage             | $V_{a0}$ | max. 550 V          |
|                           | $V_a$    | max. 250 V          |
| Anode dissipation         | $W_a$    | max. 1 W            |
| Cathode current           | $I_k$    | max. 15 mA          |
| Grid resistor             |          |                     |
| for fixed bias            | $R_g$    | max. 1 M $\Omega$   |
| for automatic bias        | $R_g$    | max. 3 M $\Omega$   |
| Grid impedance at 50 Hz   | $Z_g$    | max. 0.5 M $\Omega$ |
| Cathode to heater voltage | $V_{kf}$ | max. 200 V          |

Pentode section

|                           |           |                   |
|---------------------------|-----------|-------------------|
| Anode voltage             | $V_{a0}$  | max. 550 V        |
|                           | $V_a$     | max. 250 V        |
| Grid No.2 voltage         | $V_{g20}$ | max. 550 V        |
|                           | $V_{g2}$  | max. 250 V        |
| Anode dissipation         | $W_a$     | max. 7 W          |
| Grid No.2 dissipation     |           |                   |
| average                   | $W_{g2}$  | max. 2 W          |
| peak                      | $W_{g2p}$ | max. 3.2 W        |
| Cathode current           | $I_k$     | max. 50 mA        |
| Grid No.1 resistor        |           |                   |
| for fixed bias            | $R_{g1}$  | max. 1 M $\Omega$ |
| for automatic bias        | $R_{g1}$  | max. 2 M $\Omega$ |
| Cathode to heater voltage | $V_{kf}$  | max. 200 V        |





## R.F. PENTODE

Pentode with variable transconductance intended for use as R.F. or I.F. amplifier.

| QUICK REFERENCE DATA |                |     |            |
|----------------------|----------------|-----|------------|
| Anode current        | $I_a$          | 12  | mA         |
| Transconductance     | $S$            | 4.4 | mA/V       |
| Amplification factor | $\mu_{g_2g_1}$ | 21  |            |
| Internal resistance  | $R_i$          | 400 | k $\Omega$ |

**HEATING:** Indirect by A.C. or D.C.; series supply

|                |       |      |    |
|----------------|-------|------|----|
| Heater current | $I_f$ | 100  | mA |
| Heater voltage | $V_f$ | 12.6 | V  |

### DIMENSIONS AND CONNECTIONS

Dimensions in mm

Base: Noval

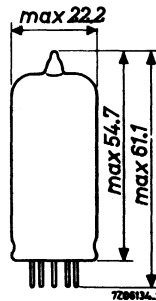
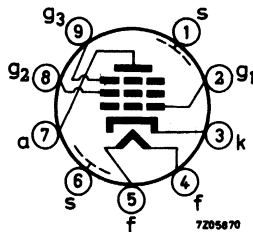

### CAPACITANCES

|                                |              |            |    |
|--------------------------------|--------------|------------|----|
| Anode to all except grid No. 1 | $C_{a(g_1)}$ | 5.1        | pF |
| Grid No. 1 to all except anode | $C_{g_1(a)}$ | 5.5        | pF |
| Anode to grid No. 1            | $C_{ag_1}$   | max. 0.002 | pF |
| Grid No. 1 to heater           | $C_{g_1f}$   | 0.05       | pF |

**TYPICAL CHARACTERISTICS**

|                      |              |      |      |
|----------------------|--------------|------|------|
| Anode voltage        | $V_a$        | 170  | V    |
| Grid No.2 voltage    | $V_{g2}$     | 100  | V    |
| Grid No.3 voltage    | $V_{g3}$     | 0    | V    |
| Anode current        | $I_a$        | 12   | mA   |
| Grid No.1 voltage    | $V_{g1}$     | -1.2 | V 1) |
| Grid No.2 current    | $I_{g2}$     | 4.4  | mA   |
| Transconductance     | S            | 4.4  | mA/V |
| Internal resistance  | $R_i$        | 0.4  | MΩ   |
| Amplification factor | $\mu_{g2g1}$ | 21   |      |

**OPERATING CHARACTERISTICS**

|                               |             |           |           |      |
|-------------------------------|-------------|-----------|-----------|------|
| Anode voltage, supply voltage | $V_a = V_b$ | 200       | 170       | V    |
| Grid No.3 voltage             | $V_{g3}$    | 0         | 0         | V    |
| Grid No.2 resistor            | $R_{g2}$    | 24        | 15        | kΩ   |
| Cathode resistor              | $R_k$       | 130       | 130       | Ω    |
| Grid No.1 voltage             | $V_{g1}$    | -1.95 -20 | -1.95 -20 | V    |
| Anode current                 | $I_a$       | 11.1 -    | 11.0 -    | mA   |
| Grid No.2 current             | $I_{g2}$    | 3.8 -     | 3.9 -     | mA   |
| Transconductance              | S           | 3.85 0.16 | 3.8 0.11  | mA/V |
| Internal resistance           | $R_i$       | 550 -     | 450 -     | kΩ   |
| Equivalent noise resistance   | $R_{eq}$    | 4.2 -     | 4.5 -     | kΩ   |
| Input conductance f = 50 MHz  | g           | 102 -     | 102 -     | μA/V |

1) In this case control grid current may occur. If this is not permissible, the negative grid bias should be increased to a value of 1.5 V at least.

TYPICAL CHARACTERISTICS AND OPERATING CHARACTERISTICS

(continued)

|                               |             |       |      |            |      |            |
|-------------------------------|-------------|-------|------|------------|------|------------|
| Anode voltage, supply voltage | $V_a = V_b$ | 100   | 100  | V          |      |            |
| Grid No.3 voltage             | $V_{g3}$    | 0     | 0    | V          |      |            |
| Grid No.2 resistor            | $R_{g2}$    | 15    | 0    | k $\Omega$ |      |            |
| Cathode resistor              | $R_k$       | 130   | 160  | $\Omega$   |      |            |
| Grid No.1 voltage             | $V_{g1}$    | -1.05 | -10  | -1.9       | -10  | V          |
| Anode current                 | $I_a$       | 6.0   | -    | 8.6        | -    | mA         |
| Grid No.2 current             | $I_{g2}$    | 2.1   | -    | 3.1        | -    | mA         |
| Transconductance              | S           | 3.2   | 0.15 | 3.3        | 0.16 | mA/V       |
| Internal resistance           | $R_i$       | 475   | -    | 300        | -    | k $\Omega$ |
| Equivalent noise resistance   | $R_{eq}$    | 3.5   | -    | 4.7        | -    | k $\Omega$ |
| Input conductance f = 50 MHz  | g           | 120   | -    | 102        | -    | $\mu$ A/V  |

LIMITING VALUES (Design centre rating system)

|                           |           |           |            |
|---------------------------|-----------|-----------|------------|
| Anode voltage             | $V_{a0}$  | max. 550  | V          |
|                           | $V_a$     | max. 250  | V          |
| Anode dissipation         | $W_a$     | max. 2.25 | W          |
| Grid No.2 voltage         | $V_{g20}$ | max. 550  | V          |
|                           | $V_{g2}$  | max. 250  | V          |
| Grid No.2 dissipation     | $W_{g2}$  | max. 0.45 | W          |
| Cathode current           | $I_k$     | max. 16.5 | mA         |
| Grid No.1 resistor        | $R_{g1}$  | max. 3    | M $\Omega$ |
| Grid No.3 resistor        | $R_{g3}$  | max. 10   | k $\Omega$ |
| Cathode to heater voltage | $V_{kf}$  | max. 150  | V          |



## A.F. OUTPUT PENTODE

Pentode intended for use as A. F. power amplifier.

| QUICK REFERENCE DATA |                |         |
|----------------------|----------------|---------|
| Anode current        | $I_a$          | 70 mA   |
| Transconductance     | $S$            | 11 mA/V |
| Amplification factor | $\mu_{g_2g_1}$ | 8       |
| Output power         | $W_o$          | 5.3 W   |

**HEATING:** Indirect by A.C. or D.C.; series supply

|                |       |        |
|----------------|-------|--------|
| Heater current | $I_f$ | 100 mA |
| Heater voltage | $V_f$ | 45 V   |

### DIMENSIONS AND CONNECTIONS

Dimensions in mm

Base: Noval

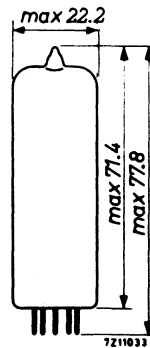
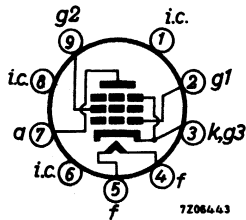

### CAPACITANCES

|                                |              |              |
|--------------------------------|--------------|--------------|
| Anode to all except grid No. 1 | $C_a(g_1)$   | 6.8 pF       |
| Grid No. 1 to all except anode | $C_{g_1(a)}$ | 13 pF        |
| Anode to grid No. 1            | $C_{ag_1}$   | max. 0.6 pF  |
| Grid No. 1 to heater           | $C_{g_1f}$   | max. 0.25 pF |

## TYPICAL CHARACTERISTICS

|                      |              |               |
|----------------------|--------------|---------------|
| Anode voltage        | $V_a$        | 170 V         |
| Grid No. 2 voltage   | $V_{g2}$     | 170 V         |
| Grid No. 1 voltage   | $V_{g1}$     | -12.5 V       |
| Anode current        | $I_a$        | 70 mA         |
| Grid No. 2 current   | $I_{g2}$     | 3.5 mA        |
| Transconductance     | $S$          | 11 mA/V       |
| Amplification factor | $\mu_{g2g1}$ | 8             |
| Internal resistance  | $R_i$        | 26 k $\Omega$ |

## OPERATING CHARACTERISTICS

### Class A 1)

|   |             |            |      |            |      |           |      |            |
|---|-------------|------------|------|------------|------|-----------|------|------------|
| Supply voltage                                | $V_b$       | 100        | 170  | V          |      |           |      |            |
| Cathode resistor                              | $R_k$       | 130        | 130  | $\Omega$   |      |           |      |            |
| Load resistance                               | $R_{a\sim}$ | 2.1        | 2.0  | k $\Omega$ |      |           |      |            |
| Grid No. 1 driving voltage                    | $V_i$       | 0 0.55 3.8 |      | 0 0.47 6.1 |      | $V_{RMS}$ |      |            |
| Anode current                                 | $I_a$       | 41         | -    | 42         | 75   | -         | 76   | mA         |
| Grid No. 2 current                            | $I_{g2}$    | 2.6        | -    | 8.6        | 4.0  | -         | 16.5 | mA         |
| Output power                                  | $W_o$       | 0          | 0.05 | 1.55       | 0    | 0.05      | 5.1  | W          |
| Distortion                                    | $d_{tot}$   | -          | -    | 10         | -    | -         | 10   | %          |
| Supply voltage                                | $V_b$       |            |      | 200        |      |           |      | V          |
| Grid No. 2 series resistor<br>(non decoupled) | $R_{g2}$    |            |      | 470        |      |           |      | $\Omega$   |
| Cathode resistor                              | $R_k$       |            |      | 215        |      |           |      | $\Omega$   |
| Load resistance                               | $R_{a\sim}$ |            |      | 2.5        |      |           |      | k $\Omega$ |
| Grid No. 1 driving voltage                    | $V_i$       |            |      | 0          | 0.52 | 7.0       |      | $V_{RMS}$  |
| Anode current                                 | $I_a$       |            |      | 65         | -    | 64        |      | mA         |
| Grid No. 2 current                            | $I_{g2}$    |            |      | 3.2        | -    | 11.4      |      | mA         |
| Output power                                  | $W_o$       |            |      | 0          | 0.05 | 5.3       |      | W          |
| Distortion                                    | $d_{tot}$   |            |      | -          | -    | 10        |      | %          |

1) Measured with  $V_k$  kept constant.

**OPERATING CHARACTERISTICS** (continued)

Class AB, two tubes in push-pull

|                            |              |                |           |
|----------------------------|--------------|----------------|-----------|
| Supply voltage             | $V_b$        | 200            | V         |
| Common cathode resistor    | $R_k$        | 120            | $\Omega$  |
| Load resistance            | $R_{aa\sim}$ | 3              | $k\Omega$ |
| Grid No. 1 driving voltage | $V_i$        | 0 0.47 14.3    | $V_{RMS}$ |
| Anode current              | $I_a$        | 2x60 - 2x64.5  | mA        |
| Grid No. 2 current         | $I_{g2}$     | 2x3.0 - 2x18.5 | mA        |
| Output power               | $W_o$        | 0 0.05 14.3    | W         |
| Distortion                 | $d_{tot}$    | - - 3.8        | %         |

**LIMITING VALUES** (Design centre rating system)

|                                     |                |           |           |
|-------------------------------------|----------------|-----------|-----------|
| Anode voltage                       | $V_{a_o}$      | max. 550  | V         |
|                                     | $V_a$          | max. 250  | V         |
| Grid No. 2 voltage                  | $V_{g2o}$      | max. 550  | V         |
|                                     | $V_{g2}$       | max. 200  | V         |
| Anode dissipation                   | $W_a$          | max. 12   | W         |
| Grid No. 2 dissipation, average     | $W_{g2}$       | max. 1.75 | W         |
|                                     | peak $W_{g2p}$ | max. 6    | W         |
| Cathode resistor                    | $I_k$          | max. 100  | mA        |
| Grid No. 1 resistor, automatic bias | $R_{g1}$       | max. 1    | $M\Omega$ |
| Cathode to heater voltage           | $V_{kf}$       | max. 200  | V         |





## SINGLE ANODE RECTIFYING TUBE

Single anode high vacuum rectifying tube.

| QUICK REFERENCE DATA |          |     |           |
|----------------------|----------|-----|-----------|
| Transformer voltage  | $V_{tr}$ | 250 | $V_{RMS}$ |
| D.C. current         | $I_o$    | 110 | mA        |

**HEATING:** Indirect by A.C. or D.C.; series supply

|                |       |     |    |
|----------------|-------|-----|----|
| Heater current | $I_f$ | 100 | mA |
| Heater voltage | $V_f$ | 38  | V  |

### DIMENSIONS AND CONNECTIONS

Base: Noval

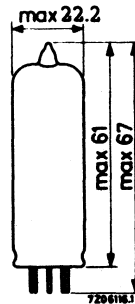
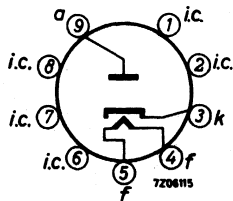

Dimensions in mm

**OPERATING CHARACTERISTICS** as single-phase half-wave rectifier

|                                     |            |     |     |     |     |           |
|-------------------------------------|------------|-----|-----|-----|-----|-----------|
| Transformer voltage                 | $V_{tr}$   | 250 | 220 | 127 | 110 | $V_{RMS}$ |
| D.C. output voltage                 | $V_o$      | 245 | 215 | 135 | 112 | V         |
| D.C. current                        | $I_o$      | 110 | 110 | 110 | 110 | mA        |
| Protecting resistance               | $R_t$      | 100 | 90  | 0   | 0   | $\Omega$  |
| Input capacitor of smoothing filter | $C_{filt}$ | 100 | 100 | 100 | 100 | $\mu F$   |

## LIMITING VALUES (Design centre rating system)

|  |                     |      |                           |
|--|---------------------|------|---------------------------|
| Anode voltage, peak inverse                  | $V_{a\text{ invp}}$ | max. | 700 V                     |
| D.C. current                                 | $I_o$               | max. | 110 mA                    |
| Anode peak current                           | $I_{ap}$            | max. | 660 mA                    |
| Cathode to heater voltage, peak, k pos.      | $V_{kfp}$           | max. | 550 V                     |
| Input capacitor of smoothing filter          | $C_{filt}$          | max. | 100 $\mu\text{F}$         |
| Protecting resistance at transformer voltage | $R_t$               | min. | 100 90 0 0 $\Omega$       |
|  | $V_{tr}$            |      | 250 220 127 110 $V_{RMS}$ |

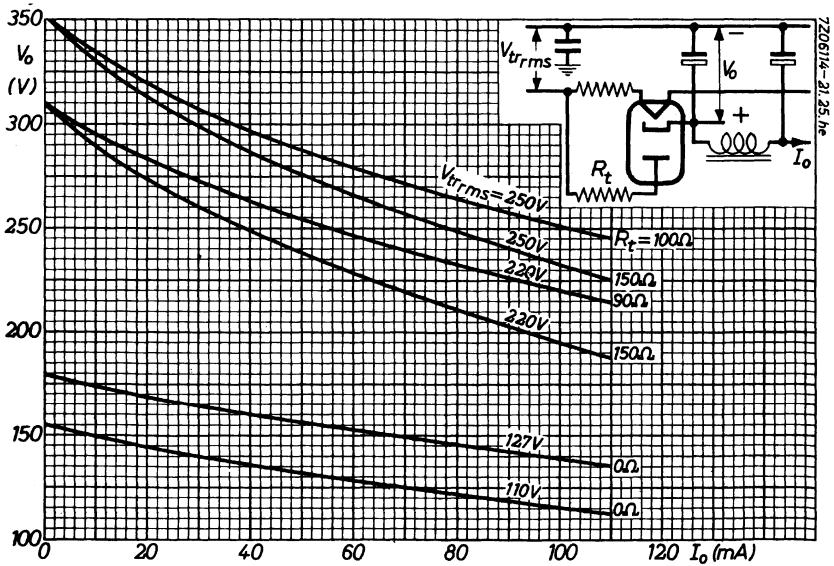

## SINGLE ANODE RECTIFYING TUBE

Single anode high vacuum rectifying tube.

| QUICK REFERENCE DATA |          |        |
|----------------------|----------|--------|
| Transformer voltage  | $V_{tr}$ | 250 V  |
| D.C. current         | $I_o$    | 100 mA |

**HEATING:** Indirect by A.C. or D.C.; series supply

|                |       |        |
|----------------|-------|--------|
| Heater current | $I_f$ | 100 mA |
| Heater voltage | $V_f$ | 31 V   |

### DIMENSIONS AND CONNECTIONS

Base: Noval

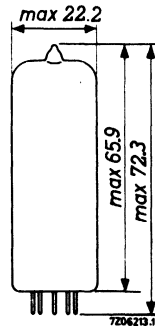
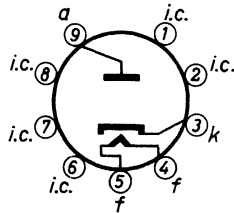

Dimensions in mm

**OPERATING CHARACTERISTICS** as single-phase half-wave rectifier.

|                                     |            |     |     |     |     |           |
|-------------------------------------|------------|-----|-----|-----|-----|-----------|
| Transformer voltage                 | $V_{tr}$   | 250 | 220 | 127 | 110 | $V_{RMS}$ |
| D.C. output voltage                 | $V_o$      | 205 | 188 | 135 | 113 | V         |
| D.C. current                        | $I_o$      | 100 | 100 | 100 | 100 | mA        |
| Protecting resistance               | $R_t$      | 210 | 160 | 0   | 0   | $\Omega$  |
| Input capacitor of smoothing filter | $C_{filt}$ | 50  | 50  | 50  | 50  | $\mu F$   |

**LIMITING VALUES** (Design centre rating system)

|   |                |          |     |     |     |     |           |
|---|----------------|----------|-----|-----|-----|-----|-----------|
| Anode voltage, peak inverse                     | $V_{a_{invp}}$ | max.     | 700 |     |     |     | V         |
| D.C. current                                    | $I_o$          | max.     | 100 |     |     |     | mA        |
| Anode current, peak                             | $I_{ap}$       | max.     | 600 |     |     |     | mA        |
| Heater to cathode voltage,<br>peak, k pos.      | $V_{kfp}$      | max.     | 550 |     |     |     | V         |
| Protecting resistance<br>at transformer voltage | $R_t$          | min.     | 210 | 160 | 0   | 0   | $\Omega$  |
|   |                | $V_{tr}$ | 250 | 220 | 127 | 110 | $V_{RMS}$ |

## INDEX OF TYPE NUMBERS

| Type No.      | Type No. | Type No. | Type No. |
|---------------|----------|----------|----------|
| DY51          | ECL82    | EY500    | PL36     |
| DY86          | ECL84    | EY500A   | PL81     |
| DY87          | ECL85    | EZ80     | PL83     |
| DY802         | ECL86    | EZ81     | PL84     |
| EAA91         | ECL805   | GY501    | PL95     |
| <b>EABC80</b> | ED500    | GZ34     | PL500    |
| EB91          | EF80     | PABC80   | PL504    |
| EBC81         | EF85     | PC86     | PL505    |
| EBF80         | EF86     | PC88     | PL508    |
| EBF89         | EF89     | PC92     | PL509    |
| EC86          | EF183    | PC900    | PL519    |
| EC88          | EF184    | PCC85    | PL802    |
| EC92          | EFL200   | PCC88    | PY81     |
| EC900         | EL34     | PCC189   | PY82     |
| ECC81         | EL36     | PCF80    | PY88     |
| ECC82         | EL81     | PCF86    | PY500    |
| ECC83         | EL84     | PCF200   | PY500A   |
| ECC85         | EL86     | PCF201   | UABC80   |
| ECC88         | EL95     | PCF801   | UBC81    |
| ECC189        | EL500    | PCF802   | UBF89    |
| ECF80         | EL503    | PCH200   | UCC85    |
| ECF86         | EL504    | PCL82    | UCH81    |
| ECF200        | EL508    | PCL84    | UCL82    |
| ECF201        | EL509    | PCL85    | UF89     |
| ECF801        | EL519    | PCL86    | UL84     |
| ECF802        | EL802    | PCL805   | UY85     |
| ECH81         | EM84     | PD500    | UY89     |
| ECH83         | EM87     | PD510    |          |
| ECH84         | EY81     | PF86     |          |
| ECH200        | EY88     | PFL200   |          |

